



---

## Vision

THE CITY OF BETTENDORF IS THE MOST LIVABLE COMMUNITY WITH RICH EDUCATIONAL, CULTURAL, AND RECREATIONAL OPPORTUNITIES WHERE WE ENJOY A VIBRANT RIVERFRONT AND A GROWING, COMPETITIVE BUSINESS ENVIRONMENT. WE TAKE PRIDE IN OUR GREAT COMMUNITY.

---

The Vision Statement for the City of Bettendorf outlines what Bettendorf wants in the future. Our preferred future is defined in value-based principles that can guide policies, decisions, and operations. The City of Bettendorf is a Premier City in which to live.

**BETTENDORF CITY COUNCIL  
COMMITTEE OF THE WHOLE  
COUNCIL CHAMBERS – CITY HALL**

**MONDAY, MARCH 2, 2026  
5:00 P.M.**

The Bettendorf City Council Committee of the Whole meeting will be open to the public. Additionally, the City of Bettendorf will broadcast this public meeting online at [www.bettendorf.org/YouTube](http://www.bettendorf.org/YouTube)

**AGENDA**

**I. PRESENTATIONS**

- Community Engagement’s Year in Review and Zencity Community Survey Results – Community Engagement Manager Angie Sharp
- East Criswell Annexation Analysis – City Staff

**II. CONSENT AGENDA ITEMS**

- Update on landscaping contracts citywide (Consent Items G, H, I, J, K, L, and M) – Public works Director Brian Schmidt

**III. REMAINING CONSENT AGENDA ITEMS**

**IV. ITEMS TO APPEAR**

**V. ITEMS ADDED BY MAYOR AND COUNCIL**

**VI. ADJOURN**

**CITY OF BETTENDORF CITY COUNCIL MEETING  
COUNCIL CHAMBERS – CITY HALL**

**TUESDAY, MARCH 3, 2026  
7:00 P.M.**

The Bettendorf City Council meeting will be open to the public. Additionally, the City of Bettendorf will broadcast this public meeting online at [www.bettendorf.org/YouTube](http://www.bettendorf.org/YouTube)

**AGENDA**

**1. ROLL CALL**

**2. PLEDGE OF ALLEGIANCE**

**3. INVOCATION**

Given by Pastor Tim Bonney of Asbury United Methodist Church

**4. PUBLIC REQUESTS OF COUNCIL**

The public is welcome to make a request of council on any item not already on the agenda for public hearing. Please limit your comments to two minutes. Please try not to be repetitive. Please refrain from outbursts, like clapping and yelling. Please be respectful with your comments.

**5. PUBLIC HEARING**

Regarding the Public Works Fire Suppression Systems Project

**6. RESOLUTION**

Council Member Brown to present a resolution approving the plans, specifications, and form of contract for the Public Works Fire Suppression Systems Project



**7. ORDINANCE**

Council Member Sechser to present the second reading of an ordinance amending Bettendorf City Code Section 12-3A-3, "Standard Specifications Adopted"

**8. CONSENT AGENDA**

**9. ADJOURN**

**CONSENT AGENDA**  
**MARCH 3, 2026**

**ALL ITEMS APPEARING BELOW ARE CONSIDERED ROUTINE BY THE CITY COUNCIL  
AND SHALL BE ENACTED BY ONE MOTION. IF DISCUSSION IS DESIRED, THAT ITEM  
SHALL BE REMOVED AND DISCUSSED SEPARATELY**

- A. Minutes from February 17 and 23, 2026. (Approve and Adopt)
- B. Resolution appointing UMB Bank, N.A., of West Des Moines, Iowa, to serve as Paying Agent, Bond Registrar, and Transfer Agent, approving the Paying Agent and Bond Registrar and Transfer Agent and Authorizing the execution of the Agreement. (Approve and Adopt)
- C. Resolution authorizing and providing for the issuance of \$19,745,000 General Obligation Bonds, Series 2026A, and levying a tax to pay said Bonds; approval of the Tax Exemption Certificate and Continuing Closure Certificate. (Approve and Adopt)
- D. Resolution setting the date for a public hearing and directing the advertising for bids for the 2026 Pavement Markings Program. (Approve and Adopt)
- E. Resolution setting the date for a public hearing and directing the advertising for bids for the 2026 Pavement Preservation Program. (Approve and Adopt)
- F. Resolution setting the date for a public hearing on the FY2027 application for State Transit Assistance Funds for Transit System Operations. (Approve and Adopt)
- G. Resolution awarding the contract for the 2026 Citywide Landscape Planting and Maintenance Program. (Approve and Adopt)
- H. Resolution awarding the contract for the 2026 Citywide Landscape Mulching Program. (Approve and Adopt)

- I. Resolution awarding the contract for the 2026 Landscape Maintenance Services for the Learning Campus & Community Center. (Approve and Adopt)
- J. Resolution awarding the contract for the 2026 Forest Grove Drive/Middle Road Corridor Landscape Maintenance Program. (Approve and Adopt)
- K. Resolution approving the contract extension for the Turf Maintenance Services Contract for City Right-of-Way (Zone 1-2026). (Approve and Adopt)
- L. Resolution approving the contract extension for the Turf Maintenance Services Contract for City Right-of-Way (Zone 2-2026). (Approve and Adopt)
- M. Resolution approving the contract extension for the Downtown Landscape Planting & Maintenance Program. (Approve and Adopt)
- N. Resolution setting the date for a public hearing for request for designation as Forest Covers/ Rivers and Streams/ River and Stream Banks for a portion of property located at 4340 Tanglewood Road to qualify for Tax Exemption. (Approve and Adopt)
- O. Resolution setting the date for a public hearing for request for designation as Forest Covers for a portion of property located at 3000 Barcelona Terrace to qualify for Tax Exemption. (Approve and Adopt)
- P. Resolution setting the date for a public hearing for request for designation as Forest Covers for a portion of property located at 8822 Wells Ferry Road to qualify for Tax Exemption. (Approve and Adopt)
- Q. ~~Resolution setting the date for a public hearing regarding the lease agreement for Dekhockey at Crow Creek Park. (Approve and Adopt)~~ **Item removed by staff 3/2/26**
- R. Resolution approving the placement of a Parking for Persons with Disabilities Sign at 510 Grant Street. (Approve and Adopt)

- S. Resolution approving the removal of a Parking for Persons with Disabilities Sign at 1524 Mississippi Blvd. (Approve and Adopt)
- T. Resolution approving tobacco license renewals for Hy-Vee Food Store and Hy-Vee Fast & Fresh. (Approve and Adopt)
- U. Resolution approving alcohol license renewals and requests for Willy's Wine & Spirits, Indian Garden Bar & Grill, Plus Saporis Mediterranean Latin Cuisine, and Scrub Pub, a new license for Azteca III, and an ownership update for Express Lane Gas & Food Mart locations (State St & Devils Glen Rd). (Approve and Adopt)
- V. Bills (Approve payment and direct City Clerk to issue checks in respective amounts)

## COUNCIL LETTER

**MEETING DATE:** March 3, 2026  
**REQUESTED BY:** Brent O. Morlok, P.E., City Engineer



---

### Item Title

Public hearing for the Public Works Fire Suppression System Project.

Resolution approving the plans, specifications and form of contract for the Public Works Fire Suppression System Project.

### Explanation

The Public Works building, including all office space, municipal garage and garage bays, do not currently have fire protection. The Fire Department worked collaboratively with Public Works and Community Development staff to prepare a plan for the installation of a full automatic fire suppression sprinkler system. Given the value of the equipment in the garage bays, that area was included with the occupied work spaces. A specialized clean agent system will also be installed to protect the IT room on the second floor.

Relationship to Goals: Upgraded City Infrastructure & Public Facilities.

### **If the matter is not budgeted in the current year, explain why funding is requested and the anticipated source:**

This project (RU0057) was approved with a total budget of \$400,000 within the Community Improvement Program (CIP) using Road Use funds.

### List Attachments

Resolution; Plans and Specifications (on file in the office of the City Engineer).

**RESOLUTION NO. \_\_\_\_\_-26**

**RESOLUTION APPROVING THE PLANS, SPECIFICATIONS, AND FORM OF CONTRACT FOR THE  
PUBLIC WORKS FIRE SUPPRESSION SYSTEM PROJECT**

WHEREAS, plans, specifications, notice to bidders and form of contract are on file in the office of the City Engineer for construction of certain improvements to the City Annex Building of said city; namely the

Public Works Fire Suppression System Project

WHEREAS, notice of hearing on the specifications, and form of contract was published as required by law, and

WHEREAS, a public hearing on the plans, specifications, and form of contract was held in the City Hall Council Chambers, 1609 State Street, Bettendorf, Iowa, at 7:00 o'clock p.m. on the 3<sup>rd</sup> day of March, 2026.

NOW, THEREFORE BE IT RESOLVED BY THE CITY COUNCIL OF THE CITY OF BETTENDORF, IOWA, that the plans, specifications, and form of contract be approved and adopted as the plans, specifications, and form of contract for said improvements.

Passed, Approved and Adopted this 3<sup>rd</sup> day of March 2026.

---

Robert S. Gallagher, Mayor

Attest:

---

Decker P. Ploehn, City Clerk

## COUNCIL LETTER

**MEETING DATE:** February 17, 2026  
**REQUESTED BY:** Brent O. Morlok, P.E., City Engineer



---

### Item Title

Public hearing and first reading on an ordinance amending Bettendorf City Code Section 12-3A-3, "Standard Specifications Adopted".

### Explanation

The City's Standard Specifications and Standard Drawings govern the types of materials, construction methods and other details for all public improvements. These specifications and detail drawings have not been updated in nearly twenty-five (25) years.

During this time, the Iowa Statewide Urban Design and Specifications (SUDAS) have been developed and adopted by many cities across the state to help provide as much uniformity in urban design and specifications as possible. Increased uniformity has led to a reduction in errors during both bidding and construction, while also encouraging more bidders. Additionally, the extensive collection of SUDAS members provides for a method to more frequently study and potentially implement the latest techniques and products in construction. This was generally much more difficult for individual cities to achieve given staffing levels and workloads.

SUDAS itself is a nonprofit entity comprised of staff from the Iowa DOT, local municipalities, counties, engineering consultants and contractors who lend their expertise to continually evaluate and update the manuals. Our City Engineer is a member of the Board of Directors, representing our Bi-State Metropolitan Planning area.

Engineering staff has reviewed the specifications manual and created an additional document, the City's Supplemental Specifications, which modify certain SUDAS sections to better reflect our needs. Staff is requesting that the current specifications and detail drawings be replaced with the SUDAS Specifications and the City Supplemental Specifications upon approval of the ordinance, for immediate implementation.

It is important to note that Engineering staff sent out draft versions of the Supplemental Specifications and detail drawings to contractors and engineers in our area for review and comment. Subsequently, these comments were incorporated into these documents to achieve consensus and to ensure transparency.

**If the matter is not budgeted in the current year, explain why funding is requested and the anticipated source:**

### List Attachments

Resolution; Ordinance; Supplemental Specifications.

**ORDINANCE AMENDING BETTENDORF CITY CODE SECTION 12-3A-3,  
"STANDARD SPECIFICATIONS ADOPTED"**

Section One. BE IT ENACTED BY THE CITY COUNCIL OF THE CITY OF BETTENDORF, IOWA, that Bettendorf City Code Section 12-3A-3 entitled, "Standard Specifications Adopted" is hereby amended by removing thereto the following section:

The type of materials and construction for improvements within subdivisions shall be in accordance with the City's standard specifications and standard drawings for construction in effect at the time of construction. Said specifications and standard drawings shall be revised from time to time as the City deems appropriate and become effective immediately upon approval by the City Council. Any project that has been received by the City for approval through the Planning and Zoning Commission and City Council prior to the adoption of the revisions shall be exempt from the revisions

And adding thereto the following section:

The Iowa Statewide Urban Design and Specifications (SUDAS) Specifications Manual, latest edition, and The City of Bettendorf Supplemental Specifications to the SUDAS Specifications Manual shall govern all construction for public improvements. Said specifications and standard drawings shall be revised from time to time as the City deems appropriate and become effective immediately upon approval by the City Council. Any project that has been received by the City for approval through the Planning and Zoning Commission and City Council prior to the adoption of the revisions shall be exempt from the revisions.

Section Two. Full Force and Effect. This ordinance shall be in full force and effect the date of passage and publication as required by law.

Section Three. Severability of Provisions. If any section, subsection, sentence, clause, phrase or portion of this ordinance be held invalid or unconstitutional by any court of competent jurisdiction, such portion shall be deemed a separate, distinct and independent provision, and such holding shall not affect the validity of the remaining portion thereof.

Section Four. Repealer. This ordinance shall be construed to repeal any prior ordinance inconsistent herewith.

Passed, Approved and Adopted this \_\_\_\_ day of \_\_\_\_\_, 2026.

\_\_\_\_\_  
Robert S. Gallagher, Mayor

Attest:

\_\_\_\_\_  
Decker P. Ploehn, City Clerk

City of Bettendorf Iowa  
Supplemental Specifications to

# SUDAS

Iowa Statewide Urban Design and Specifications  
Adopted March \_\_\_\_, 2026

**Bettendorf** IOWA  
*a premier city*

## **Supplemental Specifications :**

### **DIVISION 1 – GENERAL CONDITIONS AND COVENANTS**

#### **Section 1020 – Proposal Requirements and Conditions**

##### **1.02 Contents of the Proposal Forms**

A. DELETE and REPLACE with the following:

Each prospective bidder will be furnished with a link to the Jurisdiction’s bidding website containing the contract documents including the location and description of the proposed work, the approximate quantities of work to be performed for which bid prices are requested and the completion provisions. The contract documents will contain any special provisions that shall apply to the work to be performed.

##### **1.03 Quantities and Unit Prices**

C. DELETE and REPLACE with the following:

The proposal may have a lump sum item for mobilization. The bidder will indicate its bid price in dollars, and this will be the contract price for mobilization. If no pay item is included, mobilization shall be considered incidental, and the cost of which shall be included in other bid items.

##### **1.05 Interpretation of the Contract Documents**

DELETE and REPLACE with the following:

If any prospective bidder is in doubt as to the true meaning of any parts of the contract documents, the bidder may request an interpretation from the Engineer, through the Purchasing Division. Any interpretation of the contract documents will be made only by an addendum delivered through the Jurisdiction’s bidding website to each prospective bidder who received, or in the future requests, contract documents from the Jurisdiction.

##### **1.06 Addendum**

DELETE and REPLACE with the following:

Each bidder will receive a notice of addendum for any changes in the contract documents made prior to the time established for the receipt of bids. The notice will be delivered in the manner chosen by the Jurisdiction to the email address provided by the bidder with an acknowledgement of receipt required. Acknowledgement of the receipt of the addendum will be as provided on the Jurisdiction’s bidding website.

##### **1.09 Preparation of the Proposal**

A. DELETE and REPLACE with the following:

**Proposal:** The bidder shall execute all required documents as provided on the Jurisdiction’s bidding website.

B. DELETE.

**1.11 Irregular and Nonresponsive Proposals**

A. DELETE and REPLACE with the following :

Proposals will be considered irregular and may be rejected for any of the following reasons:

1. If submitted in any way other than through the Jurisdiction's bidding website;
2. If the bidder submits an obviously unbalanced bid. An unbalanced bid shall be defined as a bid containing lump sum prices or unit bid prices that do not reflect reasonable actual costs plus a reasonable proportionate share of the bidder's anticipated profit, overhead costs, and other indirect costs to complete that item;
3. If the proposal does not contain a unit price for each pay item listed, except in the case of authorized alternate pay items; or
4. If the bidder submits more than one proposal for the same work under the same or different names.

B. Proposals will be considered nonresponsive and shall be rejected for any of the following reasons:

4. DELETE.

**1.12 Submission of the Proposal, Identity of Bidder and Bid Security**

A. DELETE and REPLACE with the following:

Follow the instructions on the Jurisdiction's bidding website for submittal of the proposal.

**1.13 Withdrawal or Revision of the Proposal Prior to Opening of Proposals**

DELETE and REPLACE with the following:

Follow the instructions on the Jurisdiction's bidding website for withdrawal or revision of a submitted proposal prior to the time set for receiving proposals. Modifications or corrections to a proposal will not be accepted if the modifications or corrections render the bid security inadequate or if not accompanied by sufficient additional bid security.

**1.14 Opening of Proposals**

DELETE and REPLACE with the following:

The Jurisdiction's bidding website will unseal all submitted bids at the time set forth in the notice to bidders. A physical bid opening will not be held.

## **Section 1040 – Scope of Work**

### **1.06 Increase or Decrease of Work**

ADD the following:

- D. Contractor is responsible for notifying the Engineer of increased work that will accumulate additional cost. If cost is not agreed upon in advance of the work being completed, no additional payment will be made.

### **1.07 Change Orders**

ADD the following:

- C. The Contractor shall not proceed with additional work until the Contractor and the Jurisdiction have agreed upon terms and approval has been given. All documentation needed for finalizing the change order, including final quantities, will be given to the Jurisdiction no later than 30 days after the change order work has been completed. Failure to do so will result in the Contractor's forfeiture of payment.

### **1.09 Changed Site Conditions**

B. Compensation:

ADD the following:

- 3. No work that will require additional compensation will be completed prior to executing a change order covering that work.

## **Section 1070 – Legal Relations and Responsibility to the Public**

### **PART 1 – LEGAL RELATIONS**

#### **1.03 Permits and Licenses**

DELETE and REPLACE with the following:

The Contractor shall procure all necessary permits for the construction of the work and for temporary excavations, obstructions, enclosures, and street openings arising from the construction and completion of the work described in the contract documents. For Jurisdictional contracts, the cost for all required Jurisdictional permits and licenses will be waived by the Jurisdiction. The Contractor shall be responsible for all violations of the law for any case in connection with the construction of the work or caused by the obstruction of roads, streets, highways, railroads or sidewalks, and shall give all requisite notices to the Jurisdiction or other public authorities in connection therewith.

### **PART 2 – RESPONSIBILITIES TO THE PUBLIC**

#### **2.06 Traffic Control**

A. ADD the following:

3. The Contractor shall be responsible for notifying surrounding neighbors of any road closures, as detailed in contract documents.
4. If Jurisdiction deems that more traffic control devices are necessary, the Contractor shall provide at no additional cost.
5. Remove barricades and signage that is no longer needed within 24 hours.

B. Closing Streets to Traffic:

2. DELETE and REPLACE with the following:

The Contractor shall notify the Engineer at least 72 hours in advance (excluding weekends) of closing any roads, streets, or public thoroughfares. No road or street shall be closed without prior approval from the Engineer.

ADD the following:

C. Restricting Parking:

1. The Contractor is responsible for furnishing, installing, maintaining and removing any necessary temporary “No Parking” signage. The following are minimum requirements for the signage and the Engineer may add additional:
  - a. Minimum 12 X 18 sign, red on white, with specific start/stop dates/times.
  - b. Signs to have the tow symbol visible.
  - c. Signs attached to either a 48" grabber with reflective stripes or bolted to the top panel of a type 1 barricade (weighted for wind) so that the sign sticks up above the top panel.

- d. Grabber cone, or similar, are to be placed approximately 20 feet apart along the curb line from end to end.
  - e. Place signs no less than 24 hours ahead of the no parking start time.
  - f. After complete setup, take time/date stamped video or pictures of the entire setup for verification/documentation.
  - g. Check the setup at least once every 24 hours.
2. If towing is needed, the Contractor will contact the Jurisdiction.

## **2.07 Protection of Aboveground and Underground Facilities**

ADD the following:

- E. In an attempt to locate underground facilities through potholing, it is the Contractor's responsibility to properly backfill the area.
  1. If potholing within pavement, provide temporary patch by backfilling the core hole with gradation No. 11 aggregate to the bottom of the existing pavement and filling the remaining void to the top of pavement with a concrete mix or HMA mix, matching surrounding pavement and approved by the Engineer. Size of permanent replacement patch will be determined the Engineer.
  2. If potholing outside pavement, backfill with native soil and compact according to Section 3010 – Trench Excavation and Backfill. Seed and maintain until permanent growth is fully established.
  3. If potholing within sidewalks or pedestrian ramps, remove the affected panels and replace with class C concrete or class M, if approved by the Engineer.

## **Section 1080 – Prosecution and Progress**

### **1.01 Subletting or Assignment of Contract**

#### C. Subcontracts:

ADD the following:

3. If the Contractor removes a subcontractor for any reason, the Jurisdiction is not responsible for additional costs or schedule changes resulting from replacing the subcontractor.

END OF DIVISION

## **DIVISION 2 – EARTHWORK**

### **Section 2010 – Earthwork, Subgrade and Subbase**

#### **PART 1 – GENERAL**

##### **1.03 Submittals**

DELETE and REPLACE with the following:

Submit results of Modified Proctor and in-place density tests on compactions when required.

##### **1.08 Measurement and Payment**

###### **D. Topsoil:**

###### **1. On-site Topsoil**

###### **a. Measurement:**

DELETE and REPLACE with the following:

Measurement will be in cubic yards of topsoil stripped, salvaged, stockpiled and re-spread, and will be computed on the basis of a uniform finished thickness as specified.

###### **3. Off-site Topsoil**

###### **a. Measurement:**

DELETE and REPLACE with the following:

Measurement will be in square yards for furnishing, excavating, hauling and placing the material, and will be computed on the basis of a uniform 4-inch thickness, or as specified.

###### **b. Payment:**

DELETE and REPLACE with the following:

Payment will be at the unit price per square yard.

###### **E. Class 10, Class 12 or Class 13 Excavation:**

###### **3. Includes, but not limited to:**

e. ADD the following:

The Jurisdiction is responsible for compaction testing, unless otherwise specified in the contract documents. The Contractor will be responsible for payments associated with all retesting from failure of initial tests.

#### **PART 2 – PRODUCTS**

##### **2.04 Foundation Materials**

###### **B. Granular Stabilization Materials:**

ADD the following:

3. Any use of crushed concrete must be approved by the Engineer.

**D. Subbase:**

**3. Modified Subbase**

DELETE AND REPLACE with the following:

- b. The use of crushed concrete will not be allowed for modified subbase.

**PART 3 – EXECUTION**

**3.03 Stripping, Salvaging and Spreading Topsoil**

**A. Stripping and Salvaging Topsoil**

2. DELETE and REPLACE with the following:

Remove an adequate amount of topsoil from existing on-site topsoil to allow finish grading with a finished grade of a minimum 4 inches of salvaged or amended topsoil. The topsoil may be moved directly to an area where it is to be used, or may be stockpiled for future use.

**C. Topsoil Spreading and Finish Grading**

2. DELETE and REPLACE with the following:

Place topsoil at least 4 inches deep; smooth and finish grade according to the contract documents. If topsoil is being amended with compost, thoroughly blend compost with on-site topsoil at the rate specified in Section 2010, 2.01.

**3.04 Embankment Construction**

**B. Site Preparation**

ADD the following:

3. Embankments not to be built on frozen earth.

**3.06 Subgrade Preparation**

**A. Uniform Composition:**

4. DELETE and REPLACE with the following:

Construct to elevation and cross-section such that, after rolling, surface will be 0.1 feet to 0.2 feet above the required final subgrade elevation.

**B. Final Subgrade:**

DELETE and REPLACE with the following:

Complete final subgrade by excavation to grade by use of an automatically-controlled subgrade excavation machine. Final subgrade must be a uniformly planed surface without bumps or depressions.

**3.08 Subbase**

C. REMOVE this section.

**3.09 Field Quality Control**

**B. Moisture Content and Density:**

2. DELETE and REPLACE with the following:  
Compact cohesive soils to no less than 90% of maximum Modified Proctor Density;  
and cohesionless soils to no less than 70% of Relative Density.

**C. Testing:**

1. DELETE and REPLACE with the following:  
Lab Test: Determine laboratory density of material according to ASTM D1557 or  
AASHTO T-180 (Modified Proctor Density) or ASTM D4253 and ASTM D4254  
(Maximum and Minimum Index Density for Cohesionless Soils). Provide at least one  
analysis for each material type used unless provided by the Engineer.

END OF DIVISION

## **DIVISION 3 – TRENCH AND TRENCHLESS CONSTRUCTION**

### **Section 3010 – Trench Excavation and Backfill**

#### **PART 1 – GENERAL**

##### **1.08 Measurement and Payment**

###### **B. Rock Excavation**

1. DELETE and REPLACE with the following:

**Measurement:** Measurement will be by cubic yards of rock removed. The maximum allowable trench width as shown on Figures 3010.102, 3010.103 and 3010.104 will be utilized when determining the quantity. No additional compensation will be provided for over-excavation.

#### **PART 2 – PRODUCTS**

##### **2.05 Stabilization (Foundation) Materials**

- C. REMOVE this section

#### **PART 3 – EXCAVATION**

##### **3.01 Trench Excavation**

###### **B. Final Trench Backfill**

DELETE and REPLACE with the following:

Remove all topsoil and stockpile

##### **3.05 Pipe Bedding and Backfill**

###### **E. Final Trench Backfill**

5. DELETE and REPLACE with the following:

In areas to remain unpaved, terminate backfill material 4 inches below finished grade. Use topsoil for the final 4 inches above trench backfill material.

6. DELETE and REPLACE with the following:

Terminate backfill material 2 feet below subgrade elevation in areas to be paved.

END OF DIVISION

## **DIVISION 4 – SEWERS and DRAINS**

### **Section 4010 – Sanitary Sewers**

#### **PART 1 – GENERAL**

##### **1.08 Measurement and Payment**

###### **E. Sanitary Sewer Service Stub**

DELETE statement and REPLACE with the following statement:

The portion of the sanitary sewer service from the main to the property line or to the property side of the utility easement, whichever is further, or as specified in the contract documents (comply with Figure BETT4010.201).

###### **F. Sanitary Sewer Service Stub**

###### **3. Includes:**

DELETE statement and REPLACE with the following statement:

Unit price includes, but is not limited to, removal of existing pipe, trench excavation, furnishing new pipe and bedding material, furnishing and installing all necessary fittings, placing and compacting bedding and backfill material, connection back to existing service, compaction, testing and inspection.

#### **PART 2 – PRODUCTS**

##### **2.01 Sanitary Sewer Gravity Mains**

###### **A. Solid Wall Polyvinyl Chloride Pipe (PVC) 8 inch to 15 inch**

DELETE statement and REPLACE with the following statement:

1. Comply with ASTM D 3034, SDR 26.
2. Pipe stiffness per ASTM D 2412
  - a. SDR 26: Minimum pipe stiffness of 115 psi

**DELETE:**

- B. Solid Wall Polyvinyl Chloride Pipe (PVC) 18 inch to 27 inch
- C. Corrugated Polyvinyl Chloride Pipe (PVC) 8 inch to 36 inch
- D. Closed Profile Polyvinyl Chloride Pipe (PVC) 21 inch to 36 inch

###### **G. Ductile Iron Pipe (DIP) 8 inch to 54 inch**

###### **3. General :**

ADD the following:

- c. Minimum laying length of pipe shall be 18 feet.

###### **2. Interior Linings:**

DELETE statement and REPLACE with the following statement:

- b. Use linings specifically designed for sanitary sewer applications, such as cement lined. Other lining types may be allowed upon approval of the Engineer.

**H. Vitrified Clay Pipe (VCP) 8 inch to 42 inch**

ADD the following:

4. By approval of the Engineer only

**DELETE:**

- I. Double Walled Polypropylene Pipe 12 inch to 30 inch
- J. Triple Walled Polypropylene Pipe (30 inch to 36 inch)

**2.02 Sanitary Sewer Force Mains**

ADD the following:

**G. Sanitary Sewer Gravity Main, Trenchless**

1. Material shall be SDR-18 CERTA-LOC Pipe or Engineer approved equal.

**2.04 Sanitary Sewer Services**

- E. The use of any saddle wye or saddle tee must be approved by the Engineer.

**PART 3 – EXECUTION**

**3.02 Gravity Sewer Installation**

**B. Trenched**

DELETE statement and REPLACE with the following statement:

3. Lay pipe to design line and grade. Set field grades to invert of pipes. The use of a pipe laser is required.

**3.06 Sanitary Sewer Service Stubs:**

- C. DELETE statement and REPLACE with the following statement.

Install service stub from sewer main to the property line or to the property side of the utility easement, whichever is further, or as specified in the contract documents. Comply with Figure BETT4010.201

**3.10 Sanitary Sewer Cleanout**

ADD the following:

Unless approved by the Engineer, cleanouts are not allowed on sanitary sewer mains. Figure 4010.203 is only applicable to sanitary sewer services.

**3.12 Conflicts**

ADD the following:

**E. Sewer Main Crossing Granular Envelope**

Install a granular (Gradation 3) envelope where all sanitary and storm sewers cross. The area shall be the width of both trenches extending from the top of the lower pipe to the invert of the upper pipe.

## **FIGURES**

REPLACE Figure 4010.201 with Figure **BETT4010.201**.

## **SECTION 4020 – Storm Sewers**

### **PART 1 – MEASUREMENT AND PAYMENT**

#### **1.08 Storm Sewers**

##### **D. Removal of Storm Sewer:**

1. DELETE and REPLACE with the following:  
Measurement: Pipe removal will be measured in linear feet from end to end regardless of pipe size, unless specified in the contract documents.

### **PART 2 – PRODUCTS**

#### **2.02 Storm Sewers**

##### **A. Reinforced Concrete Pipe (RCP):**

3. DELETE and REPLACE with the following:  
Use rubber O-ring joints complying with ASTM C 443.

##### **B. Reinforced Concrete Arch Pipe (RCAP):**

3. DELETE and REPLACE with the following:  
Use rubber O-ring joints complying with ASTM C 443.

##### **C. Reinforced Concrete Elliptical Pipe (RCEP):**

3. DELETE and REPLACE with the following:  
Use rubber O-ring joints complying with ASTM C 443.

##### **L. Polypropylene Pipe:**

- DELETE and REPLACE with the following:
1. Comply with the following for 12 inch to 60 inch pipe:
    - a. Double walled pipe meeting ASTM F 2881.
    - b. Integral bell and spigot joint complying with ASTM D 3212 and ASTM F 477

#### **2.05 Pipe Aprons**

DELETE and REPLACE with the following:  
All pipe aprons must be concrete. Supply concrete pipe aprons according to Figure BETT4030.222 and Figure BETT4030.223. All storm sewer connected to pipe aprons must be reinforced concrete pipe to the nearest structure. Tie apron and next joint with pipe connectors.

## **PART 3 – EXECUTION**

### **3.02 Pipe Installation**

#### **A. General**

2. DELETE and REPLACE with the following:  
Begin at the lowest point in the line. Lay groove or bell end pointing upstream unless otherwise specified. The use of a pipe laser is required.

### **3.05 Pipe Jointing**

#### **E. Connections between Dissimilar Pipes:**

Add the following:

3. The use of adapters or couplings shall only be allowed for repairs. For new construction, pipe of dissimilar materials will not be allowed between structures.

### **3.08 Conflicts**

ADD the following:

#### **D. Sewer Main Crossing Granular Envelope**

Install a granular (Gradation 3) envelope where all sanitary and storm sewers cross. The area shall be the width of both trenches extending from the top of the lower pipe to the invert of the upper pipe.

## **SECTION 4030 – PIPE CULVERTS**

### **PART 1 – GENERAL**

#### **1.08 Measurement and Payment**

##### **B. Pipe Aprons**

3. DELETE and REPLACE with the following:  
**Includes:** Unit price includes, but is not limited to, trench excavation; dewatering; furnishing and installing pipe apron, furnishing all reinforcing steel and concrete and installing pipe apron footing when required for concrete pipe; furnishing, placing, and compacting bedding and backfill material; pipe connectors and other appurtenances.

##### **C. Footings for Concrete Pipe Aprons:**

DELETE this section.

### **FIGURES**

REPLACE Figure 4030.221 with Figure **BETT4030.221**

REPLACE Figure 4030.222 with Figure **BETT4030.222.**

REPLACE Figure 4030.223 with Figure **BETT4030.223.**

## **SECTION 4040 – SUBDRAINS AND FOOTING DRAIN COLLECTORS**

### **PART 1 – GENERAL**

#### **1.08 Measurement and Payment**

##### **A. Subdrains:**

3. DELETE and REPLACE with the following:

**Includes:** Unit price includes, but is not limited to, trench excavation, pipe, furnishing and placing bedding and backfill material, engineering fabric (when specified), connectors, elbows and tees. This item shall also include all outlets and connections to structures which will include, but is not limited to, pipe, non-shrink grout, coupling bands, and rodent guards for pipes 6 inches or smaller.

##### **B. Footing Drain Collectors**

3. DELETE and REPLACE with the following:

**Includes:** Unit price includes, but is not limited to, trench excavation, pipe, wyes, tap, fittings and furnishing and placing bedding and backfill material; This item shall also include all outlets and connections to structures which will include, but is not limited to, pipe, non-shrink grout, coupling bands, and rodent guards for pipes 6 inches or smaller.

##### **D. Subdrain or Footing Drain Outlets and Connections:**

DELETE this section.

### **PART 2 – PRODUCTS**

#### **2.01 Footing Drain Collectors**

Add the following:

##### **E. Corrugated Polyethylene Tubing and Fittings (Corrugated PE):**

1. Comply with AASHTO M252, Type C, corrugated interior and exterior.
2. Use only fittings supplied or recommended by pipe manufacturer for soil tight service.
3. Slot or perforate according to AASHTO M252, Type CP.

### **PART 3 – EXECUTION**

#### **3.01 Subdrains**

- A. Install Type 1 or Type 2 subdrain where specified in the contract documents. Comply with figure 4040.231.**

Add the following:

7. Install erosion barrier behind back of curb

### **FIGURES**

REPLACE Figure 4040.231 with Figure **BETT4040.231**

ADD Figure **BETT4040.234**.

## **SECTION 4050 – PIPE REHABILITATION**

### **PART 1 – GENERAL**

#### **1.07 Special Requirements**

C. DELETE and REPLACE with the following:

Unless otherwise specified, the Contractor will coordinate the use of fire hydrants with Iowa American Water Company (IAWC). Portable water meters with proper backflow prevention devices are required for use of water from all fire hydrants. IAWC will supply the RPZ backflow preventer and the meter to the Contractor. The Contractor must also notify both the City of Bettendorf's Fire Department and IAWC as to the location of meters. The use of fire hydrants is restricted to authorized personnel only. IAWC must be present and given twenty four (24) hours' notice when meters are to be moved. Per IAWC, the Contractor may be responsible to install a protective locked box over the fire hydrant, RPZ valve and meter being used at all times during the course of the program. The Contractor shall be responsible for all coordination, deposits, permits and associated fees, rental charges and charges for the volume of water used.

#### **1.08 Measurement and Payment**

A. DELETE and REPLACE with the following:

**Pipe lining:**

1. Measurement: Each type and size of pipe lining will be measured in linear foot along the centerline of the pipe lining from center of manhole to center of manhole.
2. Payment: Payment will be made at the unit price per linear foot for each type and size of pipe lining.
3. Include: Unit price includes installation of the finished liner, including preparatory cleaning and televising of sewers, manhole cleaning, removal and disposal of all debris, bypass pumping, transportation of the flexible liner and resin impregnation system, sealing at manhole walls, leakage testing, CIPP sample testing and post-insertion televising, all in accordance with the liner manufacturer's recommendations and all costs associated with the public information and notification system as well as coordinating confined space entry and inspection with the Jurisdiction.

B. DELETE and REPLACE with the following:

**Building Sewer Service Reconnection:**

1. Measurement: Each active existing building sanitary sewer service reconnected to the pipe lining, including the services reconnected by excavating and reconnecting services or by trenchless reconnection methods, will be counted.
2. Payment: Payment will be made at the unit price for each reconnection.
3. Includes: Unit price includes, but is not limited to removal of internal obstructions and debris, identifying and re-establishing all live laterals, discerning between live

and abandoned laterals and all cost associated with the public information and notification program.

ADD the following:

**D. Protruding Laterals, Cut:**

1. Measurement: Each protruding lateral cut will be counted.
2. Payment: Payment will be made at the unit price for each protruding lateral that is cut.
3. Includes: Unit price includes cutting off obstructions and removal of any and all debris from the pipe.

**E. Identify and Re-establish Live Laterals:**

1. Measurement: Each re-established lateral will be counted.
2. Payment: Payment will be made at the unit price for each re-established lateral.
3. Includes: Unit price includes, but is not limited to, identifying which laterals are live prior to lining and re-establishing flow through the live laterals.

## **PART 2 – PRODUCTS**

### **2.08 Pipe Repair Couplings for Spot Repairs by Pipe Replacement**

**C. Materials and Manufacturer :**

ADD the following:

5. All repair couplings to have stainless steel shear rings.

## **PART 3 – EXECUTION**

### **3.01 Examination**

**B. Video Inspection:**

ADD the following:

3. Follow National Association of Sewer Service Companies (NASSCO) requirements.
4. Weekly updates of field issues and televised lines from the Contractor are required for pipe lining.

**C. Service and Obstruction Location:**

ADD the following:

3. The responsibility for re-establishing only live laterals, all live laterals, and **no** abandoned ones rests with the Contractor, regardless of any information in the plans or specifications.

### **3.03 Obstructions**

ADD the following:

- D. Remotely cut off all protruding laterals to within one inch or less of the interior wall of the existing pipe using a robotic-type cutting device.

### **3.09 Cleanup and Closeout**

ADD the following:

- D. Any damage to the sewer and/or surrounding surface caused by the opening of an abandoned sewer lateral shall be the responsibility of the Contractor to correct at their own expense.

## **SECTION 4060 – CLEANING, INSPECTION AND TESTING OF SEWERS**

### **PART 1 – GENERAL**

#### **1.07 Special Requirements**

DELETE and REPLACE with the following:

Comply with National Association of Sewer Service Companies (NASSCO) requirements for all televising.

### **PART 3 – EXECUTION**

#### **3.02 Video Inspection**

##### **A. General:**

1. DELETE and REPLACE with the following:

For Jurisdiction projects, unless otherwise specified in the contract documents, conduct video inspection of all new, rehabilitated and lined sanitary and storm sewers after all backfill, compaction operations, paving and testing have been completed.

For private projects, the Jurisdiction will conduct video inspection after all backfill, compaction operations, paving and testing have been completed.

ADD the following:

5. If any section fails, requiring the removal of pavement, pavement removal limits will be at existing joints.

##### **B. Inspection Procedure:**

ADD the following:

6. Follow all NASSCO/PACP guidelines for pipe inspection

##### **C. Inspection Reporting:**

ADD the following:

1. Follow all NASSCO/PACP guidelines for inspection reporting.

END OF DIVISION

## **DIVISION 5 – WATER MAINS AND APPURTENANCES**

### **Section 5010 – Pipe and Fittings**

#### **PART 1 – GENERAL**

##### **1.07 Special Requirements**

DELETE and REPLACE with the following:

*The Iowa American Water Standard Specifications for Water Main Construction, Current Edition,*  
supersedes SUDAS Section 5010.

### **Section 5020 – Valves, Fire Hydrants and Appurtenances**

#### **PART 1 – GENERAL**

##### **1.07 Special Requirements**

DELETE and REPLACE with the following:

*The Iowa American Water Standard Specifications for Water Main Construction, Current Edition,*  
supersedes SUDAS Section 5020.

### **Section 5030 – Testing and Disinfection**

#### **PART 1 – GENERAL**

##### **1.07 Special Requirements**

DELETE and REPLACE with the following:

*The Iowa American Water Standard Specifications for Water Main Construction, Current Edition,*  
supersedes SUDAS Section 5030.

END OF DIVISION

## **DIVISION 6 – STRUCTURES FOR SANITARY AND STORM SEWERS**

### **Section 6010 – Structures for Sanitary and Storm Sewers**

#### **PART 1 – GENERAL**

##### **1.08 Measurement and Payment**

###### **D. Casting Extension Rings:**

###### **2. Payment**

DELETE and REPLACE with the following:

Payment will be incidental to manholes, intakes, and manhole or intake adjustments.

###### **H. Remove Manhole or Intake:**

###### **2. Remove Manhole**

###### **c. DELETE and REPLACE with the following**

Includes: Unit price includes, but is not limited to, removal of structure and casting, plugging pipes and placing compacted fill to the planned finished grade.

###### **3. Remove Intake**

###### **d. DELETE and REPLACE with the following**

Includes: Unit price includes, but is not limited to, removal of structure and casting, plugging pipes and placing compacted fill to the planned finished grade.

#### **PART 2 – PRODUCTS**

##### **2.07 Base**

###### **C. Intake:**

DELETE and REPLACE with the following:

Use **cast-in-place** concrete base only. Precast will not be allowed unless approved by the Engineer prior to construction.

##### **2.08 Pipe Connections**

###### **B. Non-Shrink Grout:**

DELETE and REPLACE with the following:

Use must be approved by the Engineer.

###### **D. Concrete Collar:**

DELETE and REPLACE with the following:

Comply with Section 6010, 2.02 and 2.03. Use must be approved by the Engineer for sanitary sewer applications.

## **2.09 Manhole or Intake Adjustment Rings (Grade Rings)**

A. Use of the following materials for grade adjustments of manhole or intake frame and cover assemblies:

1. DELETE and REPLACE with the following:  
Reinforced Concrete Adjustment Rings: Comply with ASTM C 478. Provide rings free from cracks voids, and other defects. Rings to be tongue and groove, interlocking grade rings.
2. High Density Polyethylene Adjustment Rings: Comply with ASTM D 1248 for recycled plastic
  - e. ADD the following:  
Use must be approved by the Engineer.
3. Expanded Polypropylene Adjustment Rings: Comply with ASTM D 4819 for expanded polypropylene when tested according to ASTM D 2375.
  - d. ADD the following:  
Use must be approved by the Engineer.

## **2.10 Castings (Ring, Cover, Grate, and Extensions)**

C. **Composite AASHTO M 306:**

5. ADD the following:  
Use must be approved by the Engineer.

F. **Casting Types:**

### **1. Manholes:**

ADD the following:

Use of Figure 6010.601 Type B and Type D by approval of the Engineer.

Use of Figure 6010.602 Type F by approval of the Engineer.

### **2. Intakes:**

- b. DELETE and REPLACE with the following:

Storm sewer casting to include environmental symbols and/or messages such as "DUMP NO WASTE, DRAINS TO RIVER." If not on casting, stamp into boxout if allowed by the Engineer.

## **2.16 Drop Connection**

B. **External:**

2. **Concrete Encasement:** Comply with Section 7010, 2.02.  
DELETE this section

## **PART 3 – EXECUTION**

### **3.01 General Requirements for Installation of Manholes and Intakes**

#### **B. Subgrade Preparation:**

2. DELETE and REPLACE with the following:

**Fill Sections:** Compact to 90% of maximum Modified Proctor Density and hand grade to accurate elevation required to place subbase, or install stabilization material as directed by the Engineer.

#### **D. Installation of Manhole or Intake Structure:**

DELETE and REPLACE with the following:

Form walls and construction joints for cast-in-place intakes or install precast intake boxes to ensure intake lids are set to match the longitudinal slope of the adjacent street unless otherwise specified in the contract documents.

#### **E. Pipes:**

2. DELETE and REPLACE with the following:

**Precast Storm Sewer Manholes or Intakes:** Construct a concrete collar around the pipe according to Section 6010, 3.05.

#### **F. Joint Sealant:**

1. DELETE and REPLACE with the following:

##### **Sanitary Sewer Manholes:**

- a. Install rubber O-ring or profile gasket (precast structures).
- b. Apply bituminous jointing material or butyl sealant wrap to exterior of all sanitary sewer manhole joints only when directed by the Engineer.

#### **I. Adjustment Ring(s):**

3. DELETE and REPLACE with the following:

Construct manholes and intakes with the following adjustment ring stack heights:

- a. Minimum: 4 inches for new manholes and intakes. No minimum for rehabilitation projects.
- b. Maximum: 16 inches for new manholes and intakes; 24 inches for existing manholes and intakes.

#### **K. Infiltration Barrier:**

##### **1. Internal or External Chimney Seal:**

- f. ADD the following:  
External chimney seal may only be used by approval of the Engineer.

**L. Backfill and Compaction:**

4. ADD the following:  
Backfill intakes per figure BETT 4040.234

**3.04 Adjustment of Existing Manhole or Intake**

**C. Major Adjustment (Adding, Removing or Modifying Riser or Cone Section):**

4. DELETE and REPLACE the following:  
Install new frame and cover or grate. Existing casting may be reinstalled when specified by the Engineer. Any existing casting not specified to be reused will become property of the Jurisdiction.
6. ADD the following:  
Any adjustment that includes dissimilar sections shall use bituminous jointing material or butyl sealant in accordance with Section 6010, 3.01 F (1).

**3.06 Drop Connection to Sanitary Sewer Manhole**

**A. Internal:**

10. ADD the following:  
Use only when approved by the Engineer

**B. External:**

3. Place concrete from the base of the manhole to the top of the elbow.  
DELETE this section.

**3.07 Removal of Manhole or Intake**

- A. DELETE and REPLACE with the following:  
Unless otherwise specified, remove the structure in its entirety.
- C. Fill remaining structure using flowable mortar:  
DELETE this section.
- D. DELETE and REPLACE with the following:  
Place compacted backfill as required for embankment or compacted backfill.

**FIGURES:**

Use of Figures 6010.304-6010.305 allowed only by approval of the Engineer.

REPLACE Figure 6010.307 with Figure **BETT6010.307**.

Use of Figures 6010.404-6010.405 allowed only by approval of the Engineer.

REPLACE Figure 6010.501 with Figure **BETT6010.501**

REPLACE Figure 6010.503 with Figure **BETT6010.503**

REPLACE Figure 6010.505 with Figure **BETT6010.505**

REPLACE Figure 6010.506 with Figure **BETT6010.506**

REPLACE Figure 6010.514 with Figure **BETT6010.514**

ADD Figure **BETT6010.520**

END OF DIVISION

## **DIVISION 7 – STREETS AND RELATED WORK**

### **Section 7010 – Portland Cement Concrete Pavement**

#### **PART 1 – GENERAL**

##### **1.08 Measurement and Payment**

- B. Air Content Deficiency:
  - DELETE this section
- I. PCC Pavement Samples and Testing:
  - DELETE this section

#### **PART 2 – PRODUCTS**

##### **2.01 Materials**

- G. Admixtures:
  - 3. DELETE and REPLACE with the following:  
**Accelerating admixtures:** Product shall be non-chloride admixture.
- H. Bars:
  - DELETE and REPLACE with the following:  
Comply with Iowa DOT Section 4151 for metallic tie bars and dowel bars or Iowa DOT Section 4156 for glass fiber reinforced polymer dowel bars. Use of glass fiber reinforced polymer dowel bars must be approved by the Engineer. Meet the tie bar requirements for bar mats. All metallic bars must be epoxy coated.
- J. Metal Keyways:
  - DELETE this section

##### **2.02 Concrete Mixes**

- A. Mix Design:
  - 1. DELETE and REPLACE with the following:  
Unless otherwise specified by the Engineer, all paving mixes shall be C3WR-C15-S20
  - 3. ADD the following:  
For all new arterial and collector streets, higher durability mixes (C-SUD or CV-SUD) shall be used unless otherwise specified by the City Engineer
- B. Consistency and Workability:
  - 2. Air Content:
    - a. DELETE and REPLACE with the following:  
For machine-placed pavement, use a target air content of 7% with a tolerance of plus or minus 1% when measured on the grade just prior to consolidation, as determined by Iowa DOT Materials I.M. 318. The target air content may be adjusted by the Engineer based on random tests of the consolidated concrete

behind the paving machine. These additional tests will be used to consider the need for a target value change and will not be used in the acceptance decision.

b. DELETE and REPLACE with the following:

For hand-placed pavement, use a target content for hand finish of 6% with a tolerance of plus or minus 1% when measured on the grade and just prior to consolidation, as determined by Iowa DOT Materials I.M. 318.

## **PART 3 – EXECUTION**

### **3.01 Equipment**

#### **C. Concrete Placement Equipment:**

##### **1. Consolidating and Finishing Equipment**

b. DELETE and REPLACE with the following:

Hand methods utilizing air screeds and vibrating screeds may be used for short pavement runs no greater than 150 feet, cul-de-sacs, driveways, and some intersections.

##### **4. Hand Finishing Equipment**

DELETE and REPLACE with the following:

Provide all finishing tools necessary for proper finishing of the concrete including straightedges for checking and correcting finished concrete surfaces. Minimum 10 foot straight edge shall be used.

##### **5. Forms**

###### **c. Rigid Forms**

2) DELETE and REPLACE with the following:

Bracing, support, and staking must prevent deflection or movement of forms. All support pins must be installed for every piece of form.

### **3.02 Pavement Construction**

#### **B. Final Subgrade / Subbase Preparation:**

##### **1. General**

b. DELETE and REPLACE with the following:

Trim the subbase to the final grade for placement of concrete. Concrete will not be allowed to be placed on subgrade

c. DELETE and REPLACE with the following:

Unless otherwise ordered by the Engineer, the subbase at time of placing concrete for concrete pavement, must be in a uniformly moist but not muddy condition to a depth of not less than 1 inch.

**E. Bar and Reinforcement Placement:**

**1. Tie Bars:**

- a. DELETE and REPLACE with the following:

Place bars prior to vibration. Bars must be supported by approved chairs or baskets, or method approved by the Engineer.

**F. Concrete Pavement Placement:**

1. DELETE and REPLACE with the following:

Use paving machine for all uniform width pavements 8 1/2 feet or more in width and 150 feet or more in length, unless alternate methods are approved by the Engineer. Screeds and laser guided screeds may be used on short pavement runs up to 150 feet.

9. Stringless Paving

- b. DELETE and REPLACE with the following:

Location and elevation of the finished slab should be verified against grade check hubs at 50 foot intervals and at critical locations, such as intakes and through intersections where grades may be flat. The Engineer may waive these requirements if experience has shown compliance with the design elevations

**L. Joint Sealing:**

- 1. Timing:**

- c. ADD the following:

Do not route, re-saw, clean or seal any joints that are less than 24 hours old.

**N. Form Removal:**

- 1. Timing:**

- a. DELETE and REPLACE with the following:

Remove forms after the initial set of the concrete has taken place, but no sooner than 12 hours after placement.

**3.03 Pavement Protection**

**A. Weather Conditions:**

- 1. Cold Weather**

**b. Protection**

- 1) DELETE and REPLACE with the following:

Shut down paving operations in time to comply with protection requirements outlined above. During cold weather, allow more time for finishing and protection. Perform all finishing and covering operations a minimum of 30 minutes prior to sunset. Temperature

restrictions and protection requirements may be modified by the Engineer.

**2. Hot Weather**

a. General

DELETE and REPLACE with the following:

- 1) During hot weather conditions, the Engineer may restrict concrete placement to early morning or evening hours.
- 2) During hot weather conditions, if at any time the temperature of the concrete reaches 85°F and/or ambient temperature reaches 90°F, the allowable time for concrete to be discharged onto the subbase will be 60 minutes. This will be measured from the time the material is batched at the plant.
- 3) Immediately apply an approved evaporation retarder to the concrete pavement and curbs or increase the surface cure application to 1.5 times the standard specified rate.
- 4) Take special precautions to ensure that the forms and subgrade are sufficiently moist or protected to avoid lowering the water content at the pavement/subgrade interface. In hot weather conditions, moisten the subgrade the evening before operations
- 5) Ensure that the time between placing and curing is minimized and eliminate delays.
- 6) Moisten concrete aggregates that are dry and absorptive
- 7) Use a fog spray to raise the relative humidity of the ambient air if there is a delay in immediately applying the curing compound.
- 8) Minimize solar heat by shading, wetting, or covering concrete chutes or other equipment that comes in contact with plastic concrete.

b. REMOVE this section in its entirety

c. REMOVE this section in its entirety

d. REMOVE this section in its entirety

**B. Night Conditions:**

DELETE and REPLACE with the following:

Perform all finishing and covering operations prior to 7 pm or 30 minutes prior to sunset, whichever is earlier. Do not commence construction until 7 am. Do not place or finish concrete under artificial light, unless approved by the Engineer

## **FIGURES**

REPLACE Figure 7010.101 with Figure **BETT7010.101**

REPLACE Figure 7010.102 with Figure **BETT7010.102**

REPLACE Figure 7010.103 with Figure **BETT7010.103**

REPLACE Figure 7010.901 with Figure **BETT7010.901**

## **Section 7020 – Hot Mix Asphalt Pavement**

### **PART 1 - GENERAL**

#### **1.08 Measurement and Payment**

- I. Fixture Adjustment:  
ADD the following:  
Comply with corresponding utility requirements for adjusting other appurtenances.

### **PART 3 – EXECUTION**

#### **3.01 HMA Pavement**

- A. Preparation of Pavement Foundation:  
ADD the following:  
Saw cut PCC curb, flag and all other headers to provide a clean vertical face.  
Apply a tack coat before each HMA lift and on the vertical face of all headers.
- E. Fixtures in the Pavement Surface:
  3. ADD the following:  
For smaller fixtures, boxout with a 2 foot by 2 foot concrete panel with 20 inch, epoxy-coated #4 bars.

## **FIGURES**

REPLACE Figure 7020.201 with Figure **BETT7020.201**

## **Section 7030 – Sidewalks, Shared Use Paths and Driveways**

### **PART 2 – PRODUCTS**

#### **2.01 Portland Cement Concrete**

- A. DELETE and REPLACE with the following:

Use only Class C concrete with materials complying with Section 7010. Use coarse aggregate of Class 2 durability or better.

### **2.07 Detectable Warnings**

DELETE and REPLACE with the following:

Use manufactured, cast-in-place, detectable warning panels with flanges / trusses, non-slip surface and raised truncated domes. Screw down warning panels will not be allowed. Comply with the Americans with Disabilities Act Accessibility Guidelines (ADAAG) for contrast and dimension requirements.

Acceptable color is Safety Yellow – Federal Standard #33538, or approved equal.

## **PART 3 – EXECUTION**

### **3.04 PCC Sidewalks, Shared Use Paths and Driveways**

#### **C. Finishing**

##### **1. Shared Use Paths and Driveways:**

ADD the following:

- c. Stamp driveway entrances in a neat, permanent and lasting manner with the year and the name of the person, firm or corporation who laid the driveway entrance. The name plate and location to be approved by the Engineer. If work is not properly stamped, the contractor shall remove the appropriate slab of sidewalk, re-pour it and stamp it.

##### **2. Sidewalks:**

ADD the following:

- g. Stamp sidewalks in a neat, permanent and lasting manner with the year and the name of the person, firm or corporation who laid the walk. The name plate to be approved by the Engineer. The walks to be stamped at each end of the property, as near the property line as is feasible, or at each end of any continuous stretch of walk exceeding 10 feet in length. Remove the appropriate slabs, re-pour and stamp if the work is not properly stamped.

#### **F. Jointing**

##### **4. Isolation Joints:**

- a. ADD the following:

Include an isolation joint at property lines.

### **3.07 Detectable Warning Installation**

#### **B. Brick Pavers:**

DELETE.

### **3.10 Cleaning**

ADD the following:

- D. Clean concrete and curing compound from detectable warning surfaces and remove protective plastic covering.

## **7040 – Pavement Rehabilitation**

### **PART 1 – GENERAL**

#### **1.08 Measurement and Payment**

##### G. Milling

##### 3. Includes:

ADD the following:

Include edge sections that cannot be reached by the milling machine.

### **PART 3 – EXECUTION**

#### **3.01 General**

##### B. DELETE.

##### C. ADD the following:

Partial width full depth patches by approval of the Engineer.

##### D. ADD the following:

Unless otherwise directed by the Engineer.

#### **3.02 Full Depth Patching**

##### A. Pavement Removal:

ADD the following:

3. If patching is due to trench work, remove at least 1 foot from edge of trench to edge of pavement.

##### C. Placing PCC Patches:

##### 4. Placing, Consolidating and Finishing the Concrete:

##### a. DELETE and REPLACE with the following:

Moisten the subbase or subgrade.

##### g. ADD the following:

Broom or drag finish if adjacent pavement texture is non-existent.

#### **3.05 Milling**

ADD the following:

- I. Thoroughly clean milled surface to allow the Engineer to properly mark out patching areas.
- J. Saw cut milled edges to provide a clean vertical face along curblines and headers.

### **FIGURES**

REPLACE Figure 7040.101 with Figure **BETT7040.101**

## **Section 7080 – Permeable Interlocking Pavers**

### **PART 1 – GENERAL**

**1.07 Special Requirements**

- B. Test Section:  
DELETE.

**FIGURES**

REPLACE Figure 7080.101 with Figure **BETT7080.101**

END OF DIVISION

## **DIVISION 8 – TRAFFIC CONTROL**

### **Section 8020 – Pavement Markings**

#### **PART 3 – EXECUTION**

##### **3.02 Construction**

###### **H. Removal of Pavement Markings:**

###### **2. Process:**

###### **d. DELETE and REPLACE with the following:**

Removal of pavement markings may be performed by high pressure water blasting only. The use of other methods including vacuum blasting, vacuum dry grinding, wet grinding, or shot blasting must be approved by the engineer. Open abrasive blasting or dry grinding without containment is not allowed.

### **Section 8030 – Temporary Traffic Control**

#### **PART 3 – EXECUTION**

##### **1.08 Measurement and Payment**

###### **A. Temporary Traffic Control:**

###### **3. DELETE and REPLACE with the following:**

**Includes:** Lump sum price includes, but is not limited to, installation, maintenance, and removal of temporary traffic control; total roadway closures with installation and removal of detour signing as shown in the contract documents; removal and reinstallation or covering of permanent traffic control devices that conflict with the temporary traffic control plan; monitoring and documenting traffic control conditions; and flaggers or automated flagger assistance devices (AFAD). When required in the contract documents, the following are also included in traffic control unless a separate bid item is provided: additional signage as required by the Engineer, portable dynamic message signs, temporary barrier rail, temporary flood lighting, and pilot cars.

### **Section 8040 – Traffic Signs and Posts**

#### **PART 1 – GENERAL**

##### **1.08 Measurement and Payment**

###### **C. Wood Posts:**

###### **2. DELETE and REPLACE with the following:**

**Payment:** Payment will be incidental to the Traffic Signs By Each pay item.

**D. Perforated Square Steel Tube Posts:**

2. DELETE and REPLACE with the following:

**Payment:** Payment will be incidental to the Traffic Signs By Each pay item.

**E. U-Shaped Rail Steel Posts:**

2. DELETE and REPLACE with the following:

**Payment:** Payment will be incidental to the Traffic Signs By Each pay item.

**F. Round Steel Posts:**

2. DELETE and REPLACE with the following:

**Payment:** Payment will be incidental to the Traffic Signs By Each pay item.

**G. Perforated Square Steel Tube Post Anchors:**

2. DELETE and REPLACE with the following:

**Payment:** Payment will be incidental to the Traffic Signs By Each pay item.

**H. Round Steel Post Anchors:**

3. DELETE and REPLACE with the following:

**Payment:** Payment will be incidental to the Traffic Signs By Each pay item.

## **PART 2 – PRODUCTS**

### **2.03 Posts**

**A. Wood Posts:**

DELETE and REPLACE with the following:

Comply with Iowa DOT Section 4164.04 for treated 4 inch by 4 inch posts. Use of this item must be approved by the Engineer.

**B. U-Shaped Rail Steel Posts:**

DELETE and REPLACE with the following:

3.0 pounds per foot, conforming with ASTM A 499, Grade 60. Punch or drill 3/8 inch diameter holes on the centerline, spaced 1 inch on center, starting 1 inch from the top and extending to the bottom of the post. Use of this item must be approved by the Engineer.

**D. U-Shaped Rail Steel Posts:**

DELETE and REPLACE with the following:

Minimum 2 3/8 inch diameter round 16 gauge galvanized steel with 0.06 inch minimum wall thickness. Furnish anchors 2 3/8 inch diameter 12 gauge galvanized steel with 0.10 wall thickness. Use of this item must be approved by the Engineer.

END OF DIVISION

## **DIVISION 9 – SITE WORK AND LANDSCAPING**

### **Section 9010 – Seeding**

#### **PART 1 – GENERAL**

##### **1.08 Conventional Seeding**

DELETE and REPLACE with the following:

- A. Seeding, Fertilizing, and Mulching for Conventional Seeding:
  - 1. Measurement: Measurement will be in acres for each type of seed.
  - 2. Payment: Payment will be in unit price per acre for each type of seed.
  - 3. Includes: Unit price includes, but is not limited to, removal of rock and other debris from the area; repairing rills and washes; preparing the seedbed; furnishing and placing seed, including any treatment required; furnishing and placing fertilizer and mulch; and furnishing water and other care during the care period, unless these items are bid separately.
  
- D. Watering:

DELETE and REPLACE with the following:

  - 1. Watering will be considered incidental to all Seeding, Fertilizing and Mulching for Conventional Seeding, Hydraulic Seeding and Pneumatic Seeding.

### **Section 9020 – Sodding**

#### **PART 3 – EXECUTION**

##### **3.06 Maintenance**

- B. Maintenance of sodded areas includes:

DELETE the following:

- 3. Mowing

### **Section 9040 – Erosion and Sediment Control**

#### **PART 1 – GENERAL**

##### **1.08 Measurement and Payment**

- D. Filter Socks:

- 1. Installation:
  - c. DELETE and REPLACE with the following:

Includes: Unit price includes, but is not limited to, anchoring stakes and removal which includes, but is not limited to, restoration of the area to finished grade and off-site disposal of filter socks and accumulated sediment.

2. Removal:  
DELETE this section.

F. Wattles:

1. Installation:
  - c. DELETE and REPLACE with the following:  
Includes: Unit price includes, but is not limited to, anchoring stakes and removal which includes, but is not limited to, restoration of the area to finished grade and off-site disposal of wattle and accumulated sediment.
2. Removal:  
DELETE this section.

N. Silt Fence or Silt Fence Ditch Check:

1. Installation:
  - c. DELETE and REPLACE with the following:  
Includes: Unit price includes, but is not limited to, anchoring posts, removal of sediment which includes, but is not limited to, dewatering and removal and offsite disposal of accumulated sediment and removal which includes, but is not limited to, restoration of the area to finished grade and off-site disposal of fence, posts, and accumulated sediment
2. Removal of Sediment:  
DELETE this section.
3. Removal of Device:  
DELETE this section.

P. Dust Control:

1. Water for dust control:
  - a. DELETE and REPLACE with the following:  
Measurement: Measurement will be per application which includes a sufficient quantity of material necessary to control the dust.
  - b. DELETE and REPLACE with the following:  
Payment: Payment will be at the unit price per each application

T. Inlet Protection Device:

1. Installation:
  - c. DELETE and REPLACE with the following:  
Includes: Unit price includes, but is not limited to, removal of the device upon completion of the project and maintenance which includes, but is not limited to, removal and off-site disposal of accumulated sediment.
2. Maintenance:

DELETE this section.

W. Linear Erosion Control:

1. Installation:

c. DELETE and REPLACE with the following:

Includes: Unit price includes, but is not limited to, anchoring posts and anchoring stakes and removal which includes, but is not limited to, restoration of the area to finished grade and off-site disposal of fence, filter socks, wattles, anchoring posts, anchoring stakes, and accumulated sediment.

2. Removal:

DELETE this section.

END OF DIVISION

## **DIVISION 11 – MISCELLANEOUS**

### **Section 11010 – Construction Survey**

#### **PART 3 – EXECUTION**

##### **3.03 Construction Staking**

C. Pipe Culverts:

4. ADD the following:

Provide grade sheets that include pipe type, slope, linear footage, invert elevation and any other relevant information.

D. Sanitary and Storm Sewers:

6. ADD the following:

Provide grade sheets that include pipe type, slope, linear footage, invert elevation and any other relevant information.

F. Paving:

2. Stringless Paving:

e. ADD the following:

Location and elevation of the finished slab should be verified against grade check hubs at 50 foot intervals and at critical locations, such as intakes and through intersections where grades may be flat. The Engineer may waive these requirements if experience has shown compliance with the design elevations

### **Section 11030 – Temporary Services During Construction**

#### **PART 1 – GENERAL**

##### **1.07 Special Requirements**

A. ADD the following:

When the proposal form does not include a bid item for temporary services during construction, all costs incurred by the contractor for these items are incidental to other work and no separate payment will be made.

END OF DIVISION

- ① Place bedding and backfill material as required for sewer main.
- ② Service Line Slope:  
4 inch: 2% to 5%  
6 inch and greater: 1% to 5%
- ③ Run service line to the property side of the easement or the property line if no easement exists.

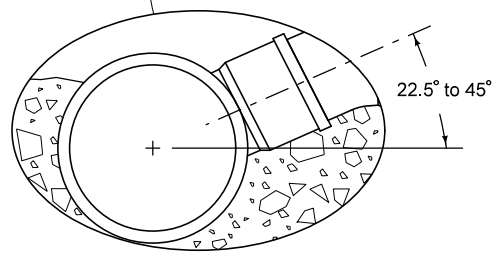
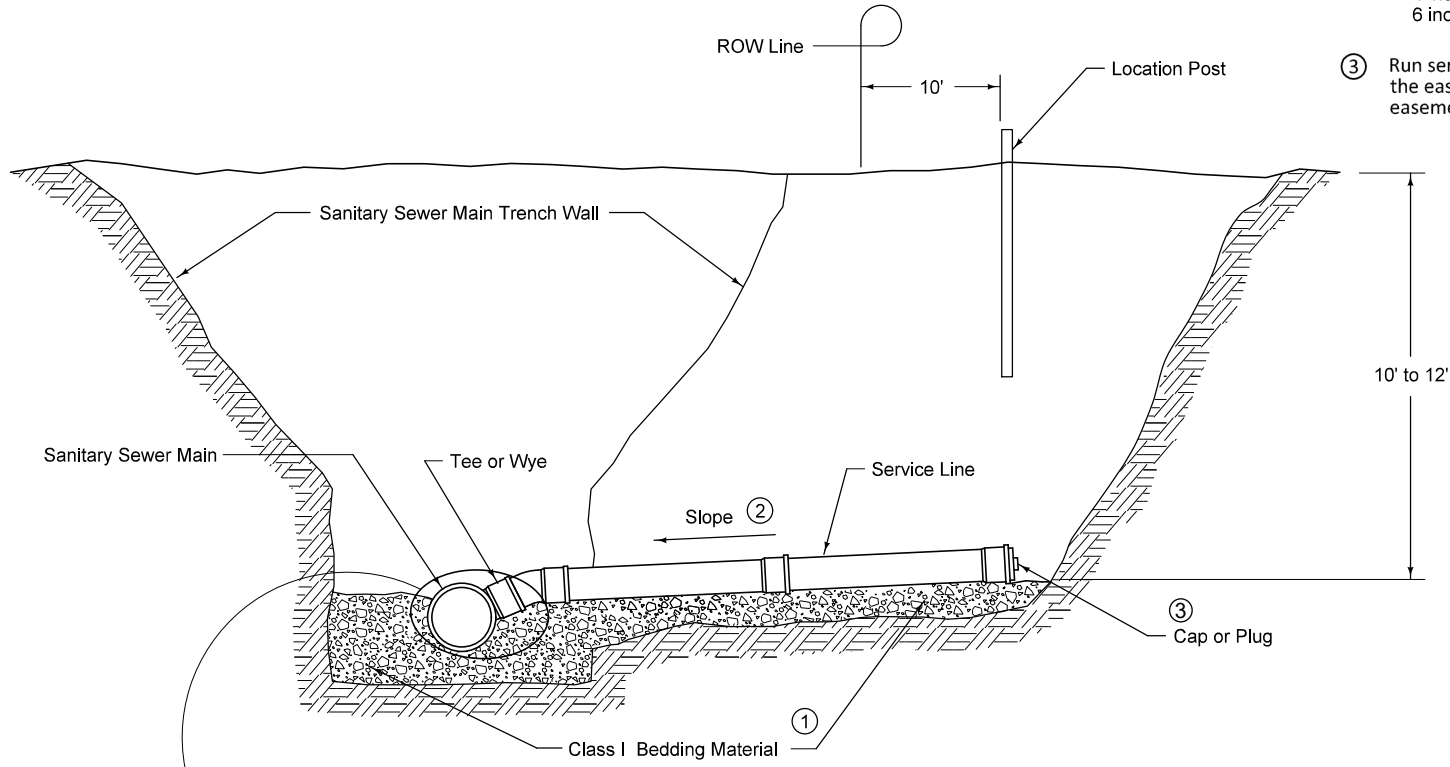

SANITARY SEWER SERVICE STUB

FIGURE 400.201 SHEET 1 OF 2

	REVISION	
	2	09/15/25
	BETT4010.201	
SHEET 1 of 2		
<b>SANITARY SEWER SERVICE STUB</b>		

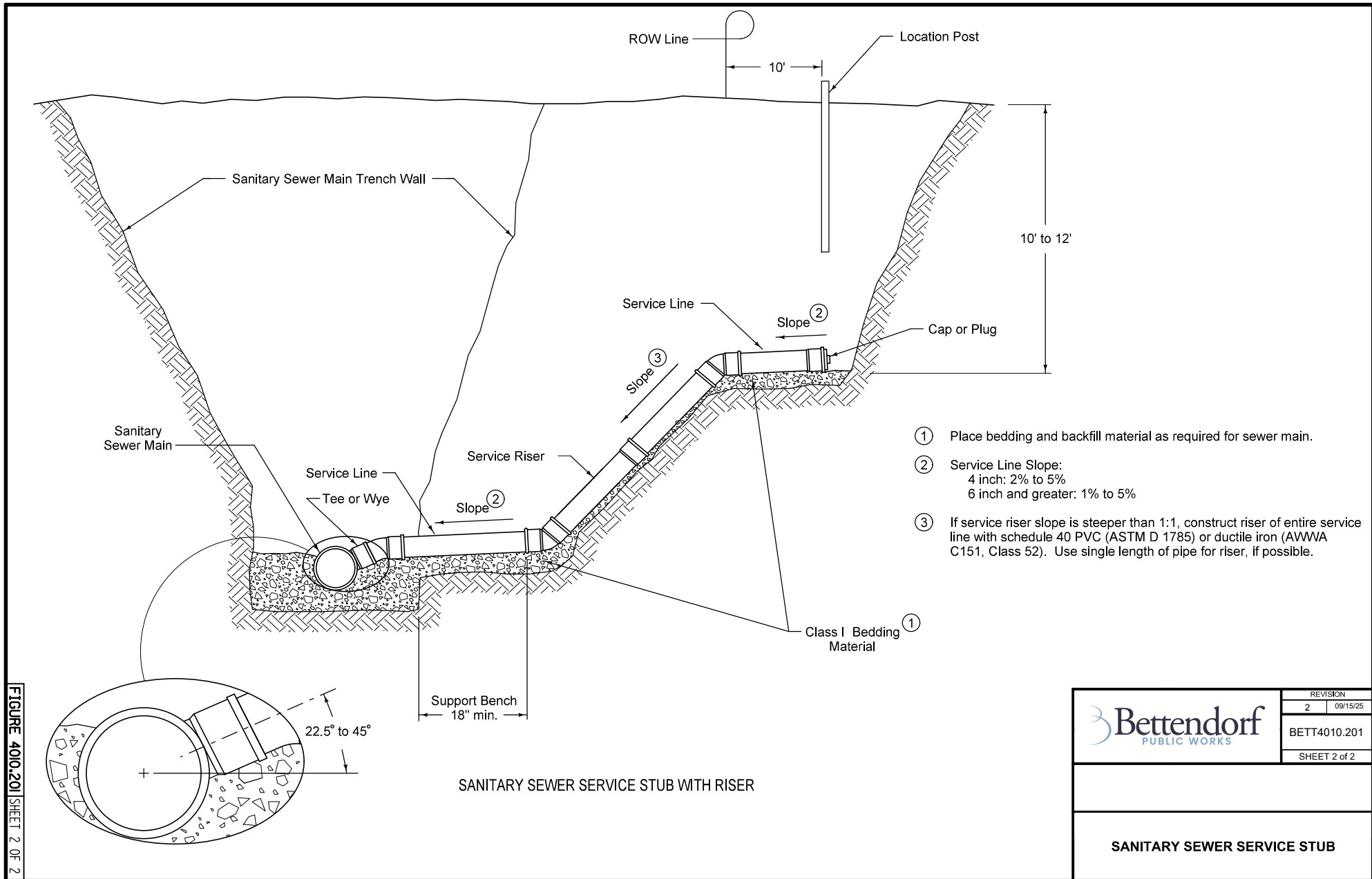

- ① Place bedding and backfill material as required for sewer main.
- ② Service Line Slope:  
4 inch: 2% to 5%  
6 inch and greater: 1% to 5%
- ③ If service riser slope is steeper than 1:1, construct riser of entire service line with schedule 40 PVC (ASTM D 1785) or ductile iron (AWWA C151, Class 52). Use single length of pipe for riser, if possible.

SANITARY SEWER SERVICE STUB WITH RISER

FIGURE 4010.201 SHEET 2 OF 2

	REVISION	
	2	09/15/25
	BETT4010.201	
SHEET 2 of 2		
<b>SANITARY SEWER SERVICE STUB</b>		

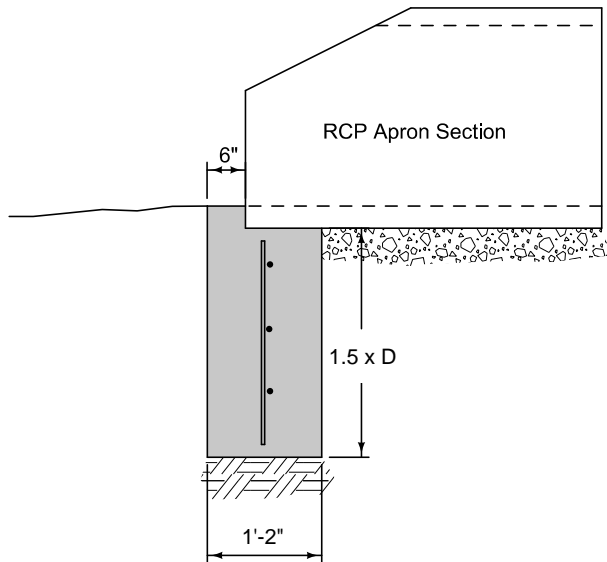

TYPICAL SECTION

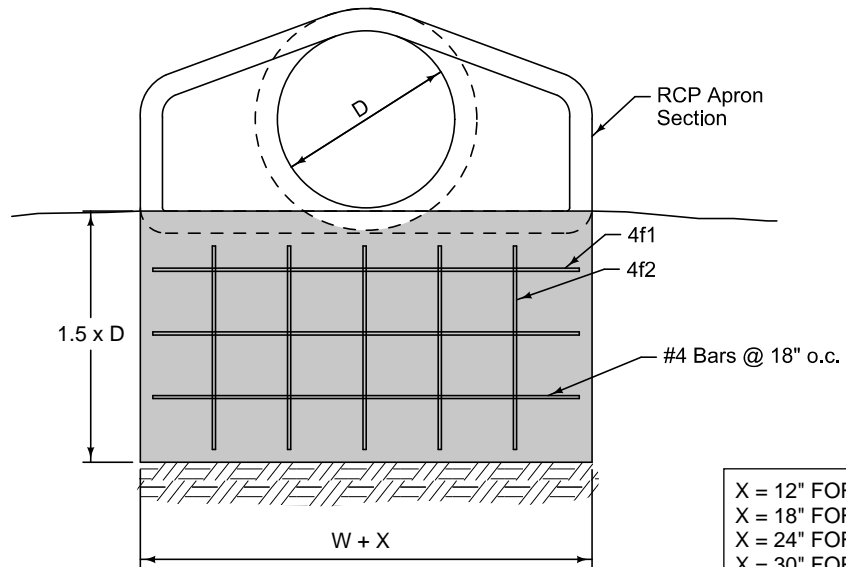

ELEVATION

X = 12" FOR 12" DIA TO 18" DIA  
 X = 18" FOR 21" DIA TO 33" DIA  
 X = 24" FOR 36" DIA TO 48" DIA  
 X = 30" FOR GREATER THAN 48" DIA

REINFORCING BAR LIST

D	W	Mark	Size	Length	Count
12"	2'-4"	4f1	4	3'-0"	3
		4f2	4	2'-6"	2
15"	2'-10 1/2"	4f1	4	3'-6 1/2"	3
		4f2	4	2'-6"	2
18"	3'-5"	4f1	4	4'-1"	3
		4f2	4	2'-6"	3
24"	4'-6"	4f1	4	5'-8"	3
		4f2	4	2'-6"	3
30"	5'-7"	4f1	4	6'-8"	3
		4f2	4	3'-3"	4
36"	6'-8"	4f1	4	8'-4"	3
		4f2	4	4'-0"	5
42"	7'-3"	4f1	4	8'-11"	3
		4f2	4	4'-9"	5

D	W	Mark	Size	Length	Count
48"	7'-10"	4f1	4	9'-6"	3
		4f2	4	5'-6"	6
54"	8'-5"	4f1	4	10'-7"	3
		4f2	4	6'-3"	6
60"	8'-11"	4f1	4	11'-1"	3
		4f2	4	7'-0"	6
66"	8'-11"	4f1	4	11'-1"	3
		4f2	4	7'-9"	6
72"	10'-0"	4f1	4	12'-2"	3
		4f2	4	8'-6"	7
78"	10'-7"	4f1	4	12'-9"	3
		4f2	4	9'-3"	7
84"	11'-1"	4f1	4	13'-3"	3
		4f2	4	10'-0"	8

FIGURE 4030.221 SHEET 1 OF 1

	REVISION	
	1	06/02/25
	BETT4030.221	
SHEET 1 of 1		
RCP APRON SECTION FOOTING		

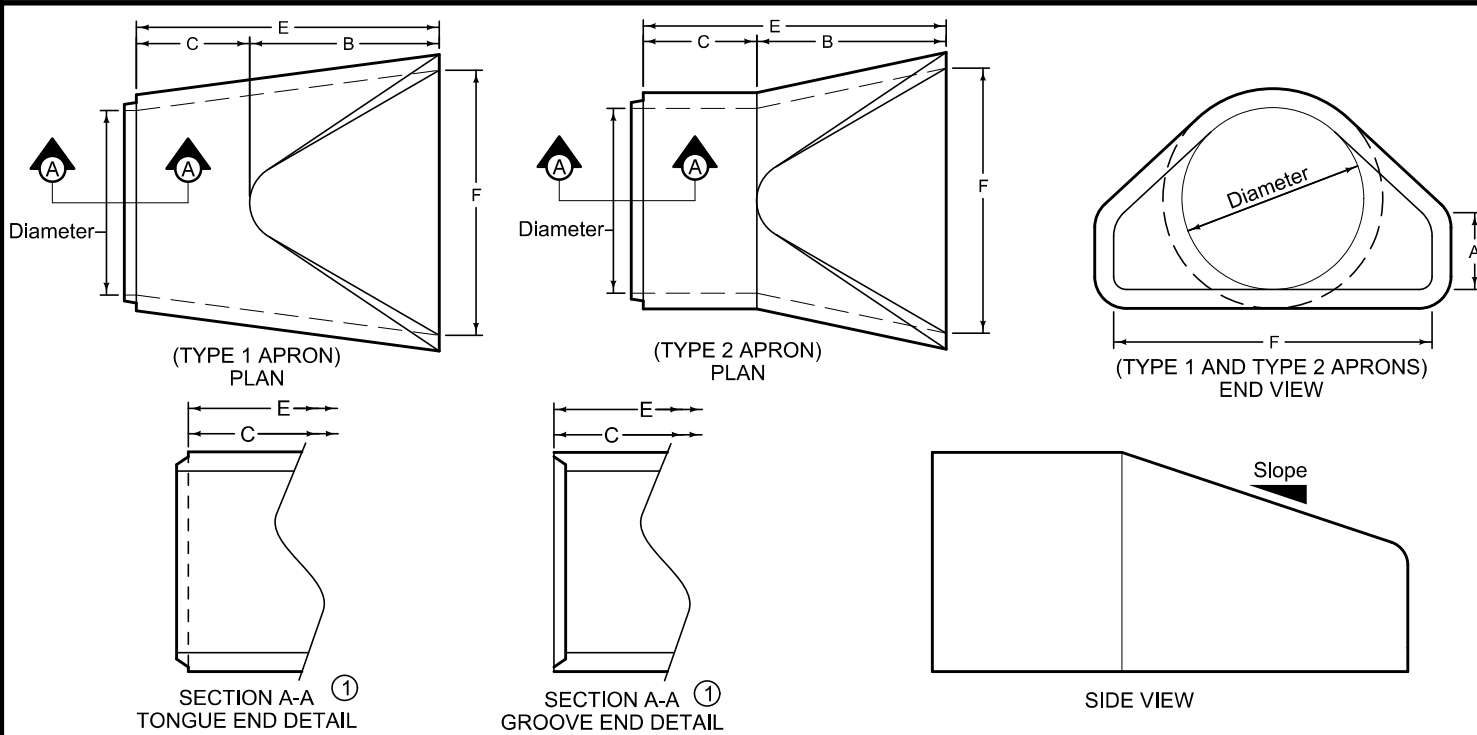

Dimension 'E' shown is the minimum and is considered the design length. Adjust for any difference between the actual length of concrete apron installed and the length indicated below for the length of concrete culvert pipe furnished.

- ① Tongue end used on inlet end section. Groove end used on outlet end section.

NOTE:  
Tie first two joints with pipe connectors.

TYPE 1 APRONS						
DIAM.	SLOPE	A	B	MINIMUM		F
				C	E	
12"	2.4:1	4"	2'-0"	4'- $\frac{7}{8}$ "	6'- $\frac{7}{8}$ "	2'-0"
15"	2.4:1	6"	2'-3"	3'-10"	6'-1"	2'-6"
18"	2.3:1	9"	2'-3"	3'-10"	6'-1"	3'-0"
21"	2.4:1	9"	3'-0"	3'-1 $\frac{1}{2}$ "	6'-1 $\frac{1}{2}$ "	3'-5"
24"	2.5:1	9 $\frac{1}{2}$ "	3'-7 $\frac{1}{2}$ "	2'-6"	6'-1 $\frac{1}{2}$ "	4'-0"
27"	2.5:1	10 $\frac{1}{2}$ "	4'-1"	2'-0"	6'-1 $\frac{1}{2}$ "	4'-4"
30"	2.5:1	12"	4'-6"	1'-7 $\frac{3}{4}$ "	6'-1 $\frac{3}{4}$ "	5'-0"
36"	2.5:1	15"	5'-3"	2'-9"	8'-0"	6'-0"
42"	2.5:1	21"	5'-3"	2'-9"	8'-0"	6'-6"
48"	2.5:1	24"	6'-0"	2'-0"	8'-0"	7'-0"
54"	1.8:1	27"	5'-0"	3'-0"	8'-0"	7'-6"
60"	1.6:1	29 $\frac{1}{2}$ "	5'-0"	3'-0"	8'-0"	8'-0"
66"	1.7:1	30"	6'-0"	2'-3"	8'-3"	8'-0"
72"	1.6:1	30"	6'-6"	1'-9"	8'-3"	9'-0"
78"	1.8:1	36"	7'-6"	1'-9"	9'-3"	9'-6"
84"	1.3:1	29 $\frac{1}{2}$ "	6'-9"	2'-6 $\frac{1}{2}$ "	9'-3 $\frac{1}{2}$ "	10'-0"

TYPE 2 APRONS						
DIAM.	SLOPE	A	B	MINIMUM		F
				C	E	
12"	2.4:1	4"	2'-0"	4'- $\frac{7}{8}$ "	6'- $\frac{7}{8}$ "	2'-0"
15"	2.4:1	6"	2'-3"	3'-10"	6'-1"	2'-6"
18"	2.3:1	9"	2'-3"	3'-10"	6'-1"	3'-0"
21"	2.4:1	9"	3'-0"	3'-1 $\frac{1}{2}$ "	6'-1 $\frac{1}{2}$ "	3'-5"
24"	2.5:1	9 $\frac{1}{2}$ "	3'-7 $\frac{1}{2}$ "	2'-6"	6'-1 $\frac{1}{2}$ "	4'-0"
27"	2.5:1	10 $\frac{1}{2}$ "	4'-1"	2'-0"	6'-1 $\frac{1}{2}$ "	4'-4"
30"	2.5:1	12"	4'-6"	1'-7 $\frac{3}{4}$ "	6'-1 $\frac{3}{4}$ "	5'-0"
36"	2.5:1	15"	5'-3"	2'-9"	8'-0"	6'-0"
42"	2.5:1	21"	5'-3"	2'-9"	8'-0"	6'-6"
48"	2.5:1	24"	6'-0"	2'-0"	8'-0"	7'-0"
54"	1.9:1	24 $\frac{1}{2}$ "	5'-5"	2'-7"	8'-0"	7'-6"
60"	1.4:1	24 $\frac{1}{2}$ "	5'-0"	3'-0"	8'-0"	8'-0"
66"	1.7:1	30"	6'-0"	2'-3"	8'-3"	8'-0"
72"	1.4:1	24"	6'-6"	1'-9"	8'-3"	9'-0"
78"	1.8:1	36"	7'-6"	1'-9"	9'-3"	9'-6"
84"	1.5:1	23 $\frac{1}{2}$ "	7'-6 $\frac{1}{2}$ "	1'-9"	9'-3 $\frac{1}{2}$ "	10'-0"

	REVISION	
	New	06/02/25
	BETT4030.222	
SHEET 1 of 1		
<p>CIRCULAR CONCRETE APRONS</p>		

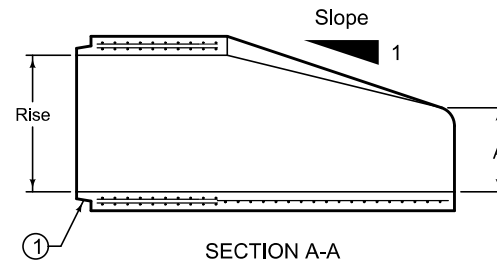
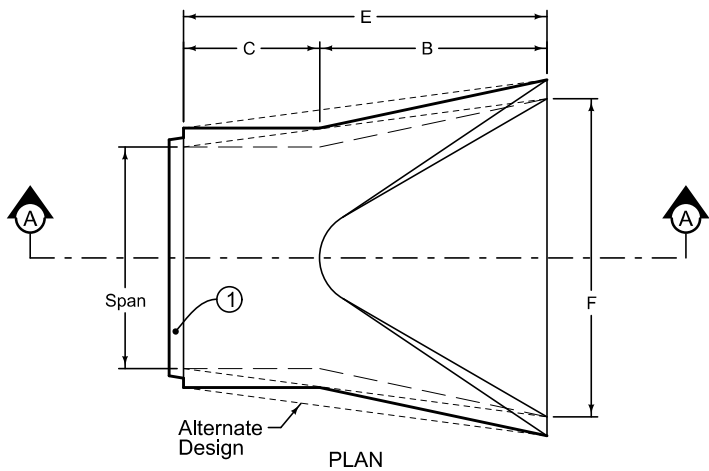

Dimension 'E' shown is the minimum and is considered the design length. Adjust for any difference between the actual length of concrete apron installed and the length indicated below for the length of concrete culvert pipe furnished.

① Tongue end used on inlet end section. Groove end used on outlet end section.

NOTE:  
Tie first 2 joints with pipe connectors.

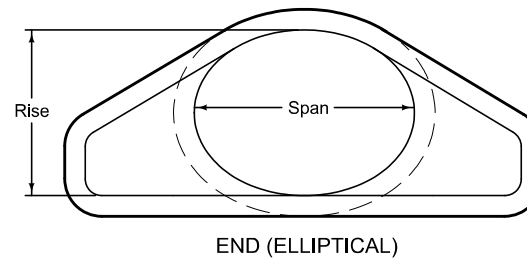
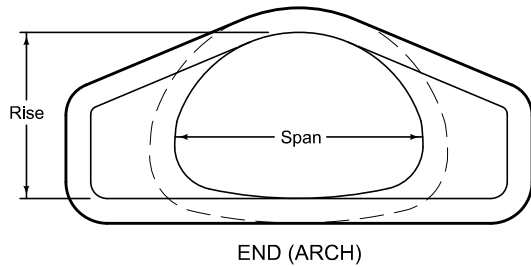

EQUIVALENT DIAMETER Inches	SLOPE	APPROXIMATE DIMENSIONS Inches				
		A	B	C	E	F
18	3:1	7	27	45	72	36
24	3:1	8 $\frac{1}{2}$	39	33	72	48
30	3:1	9 $\frac{1}{2}$	50	46	96	60
36	3:1	11 $\frac{3}{8}$	60	36	96	72
42	3:1	15 $\frac{3}{16}$	60	36	96	78
48	3:1	21	60	36	96	84
54	3:1	25 $\frac{1}{2}$	60	36	96	90
60	3:1	31	60	36	96	96
72	2:1	31	60	39	99	120
84	2:1	21 $\frac{3}{2}$	83	19	102	144

ARCH PIPE

EQUIVALENT DIAMETER Inches	SLOPE	APPROXIMATE DIMENSIONS Inches				
		A	B	C	E	F
18	3:1	7 $\frac{1}{2}$	27	45	72	36
24	3:1	8 $\frac{3}{2}$	39	33	72	48
30	3:1	9 $\frac{1}{2}$	54	18	72	60
36	2.5 to 1	11 $\frac{1}{8}$	60	24	84	72
42	2.5 to 1	15 $\frac{3}{2}$	60	36	96	78
48	2.5 to 1	21	60	36	96	84
54	2.5 to 1	25 $\frac{1}{2}$	60	36	96	90
60	2.5 to 1	30	60	36	96	96
72	2.5 to 1	36	63	33	96	108
90	1.6 to 1	36 $\frac{1}{2}$	58	38	96	113

ELLIPTICAL PIPE

	REVISION	
	New	09/10/25
BETT4030.223		
SHEET 1 of 1		
<b>ARCH AND ELLIPTICAL CONCRETE PIPE APRONS</b>		

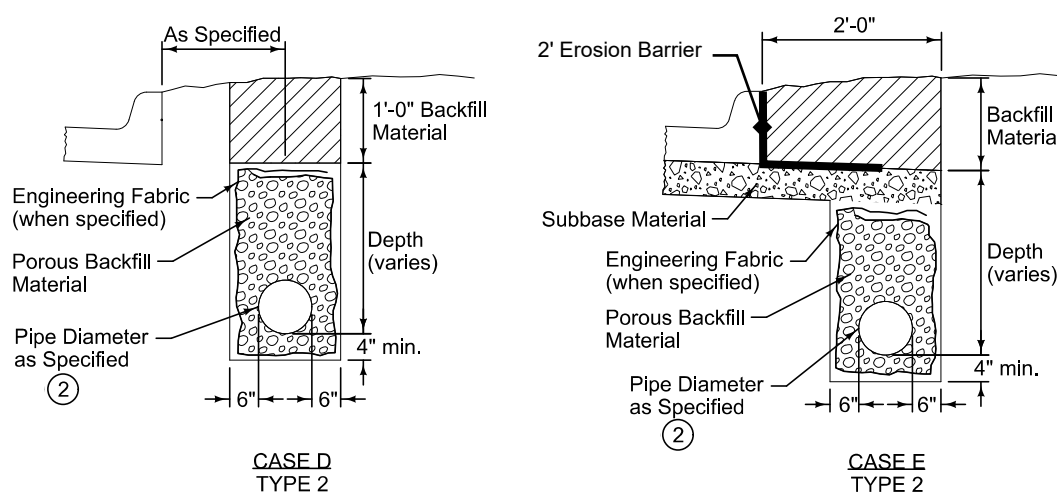
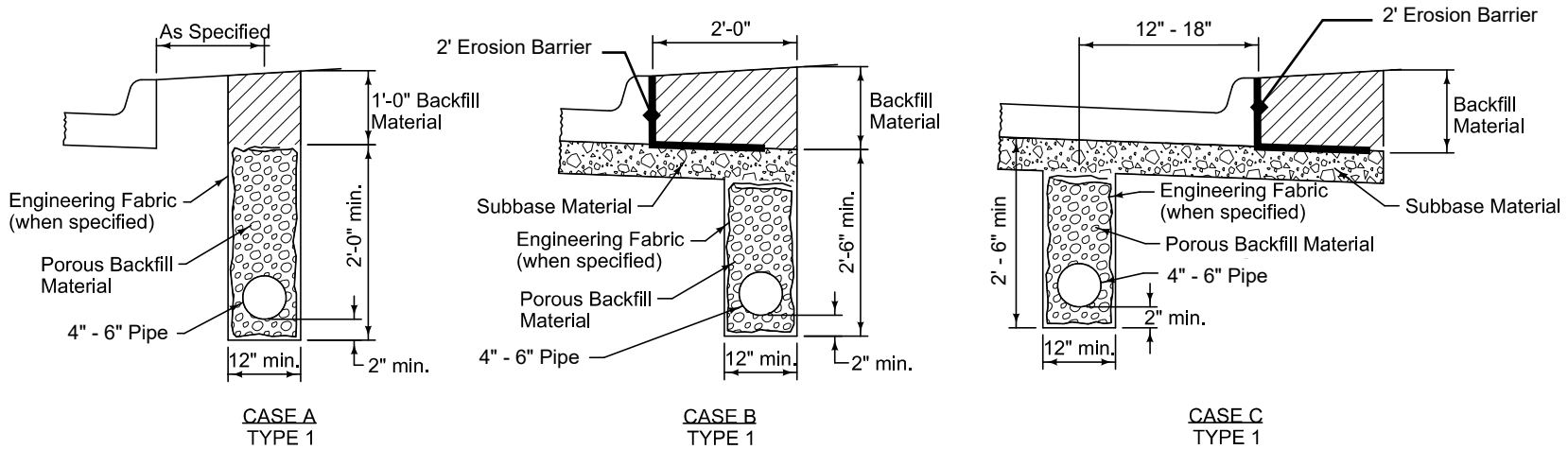

Type 1 installation is for longitudinal subdrain only. Type 2 installation is for combination subdrain/footing drain collectors.

② When concrete pipe is specified, wrap pipe joints with engineering fabric. Do not apply joint sealant. Comply with Figure 4020.211

FIGURE 4040.231 SHEET 1 OF 1

	REVISION	
	1	09/10/25
	BETT4040.231	
SHEET 1 of 1		

SUBDRAINS

# INTAKE BACKFILL, DRAIN TILE AND AND DRAIN TILE CONNECTION

**GENERAL NOTES.** All intakes constructed under this contract shall be constructed with 4 inch or 6 inch drain tile as specified in these General Notes and Notes 1 thru 3. Although this detail depicts a single intake, it applies to double and triple as well. All connections to structures, fittings and caps associated with drain tile work shall be considered incidental to 4 inch drain tile. The holes in the intake walls for connection of drain tile shall be either precast into the intake or drilled and knocked out. Jackhammering is NOT an acceptable method of providing the holes. Contractor shall refer to Standard Drawing #52 for other general requirements of 4 inch and 6 inch drain tile.

**NOTE 1.** This 6 inch drain tile shall be stubbed out behind the curb from newly constructed intakes when storm sewer pipe exists beneath the gutter line. The drain tile connection to the intake shall be made as near as possible to the flowline of the intake. The tile will rise to 30 inches below the bottom of pavement slab at the edge of the boxout. If concrete patching is proposed adjacent to the intake boxout, the drain tile shall be extended (at a depth of 30 inches below the bottom of pavement slab) behind the entire length of the patch. Backfill within the excavation limits of the intake shall be Class A crushed stone beneath the drain tile and Gradation 12 or 29 above and surrounding the drain tile.

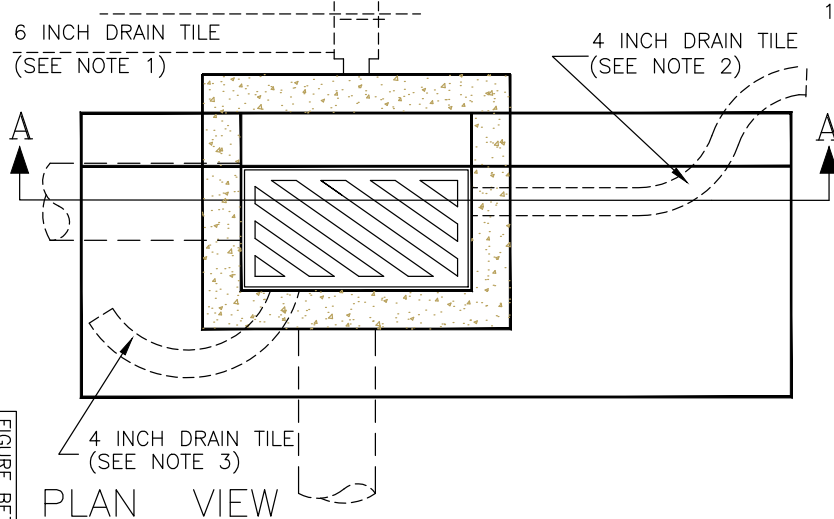

**NOTE 2.** This 4 inch drain tile shall be stubbed out under street gutterline from newly constructed intake when no storm sewer pipe exists beneath the gutterline. The end of the drain tile, at the edge of the boxout, shall be bent back behind the back of curb. The drain connection to the intake shall be made as near as possible to the flowline of the intake. The tile will rise to 30 inches below the bottom of pavement slab at the edge of the boxout. If concrete patching is proposed adjacent to the intake boxout, the drain tile shall be extended (at a depth of 30 inches below the bottom of pavement slab) under the gutterline the entire length of the patch. Drain tile shall then be bent back behind the back of curb at the edge of the patch. Backfill within the excavation limits of the intake shall be Class A crushed stone beneath the drain tile and Gradation 12 or 29 above and surrounding the drain tile.

**NOTE 3.** This 4 inch drain tile shall be stubbed out from the flowline of the intake and extended between storm sewer pipes. Several of these drain tiles may be required per intake if several storm sewer pipes connect to the intake. This drain tile will be backfilled beneath and above with gradation 12 or 29 Class A crushed stone.

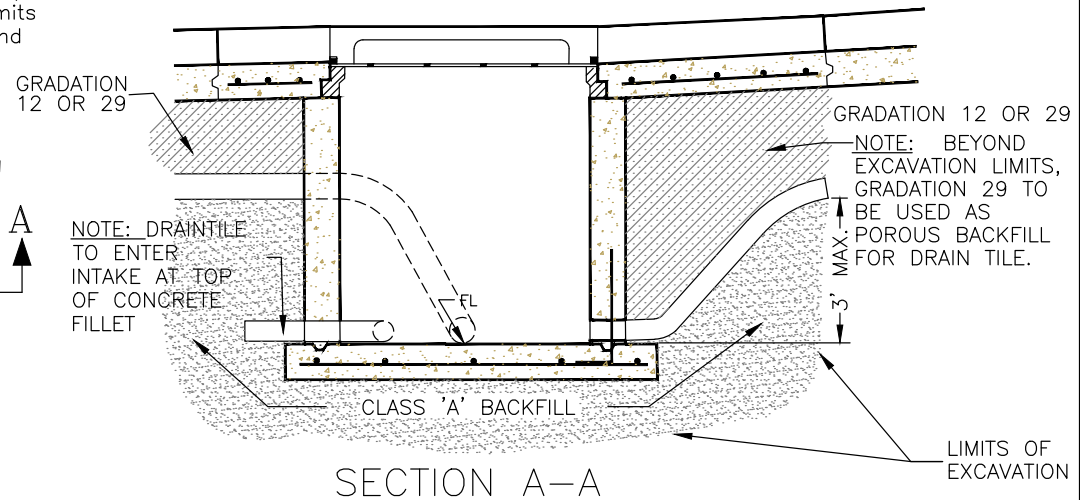

FIGURE BETT4040.234 SHEET 1 OF 1

	REVISION
	1   09-15-25
STANDARD ROAD PLAN	BETT4040.234
SHEET 1 of 1	
REVISIONS:	
SUBAS DIRECTOR	DESIGN METHODS ENGINEER
<b>INTAKE BACKFILL, DRAIN TILE AND DRAIN TILE CONNECTION</b>	

Construct drop and overflow from ductile iron pipe of same diameter specified for sewer main. Provide mechanical joints for all ductile iron pipe and fittings.

- ① Place Class I bedding material, CLSM, flowable mortar, or concrete from top of elbow to bottom of sewer main.
- ② Encase elbow in concrete. 12 inches minimum on all sides.

NOTE: CONCRETE ENCASEMENT NOT NECESSARY WITH D.I.P.

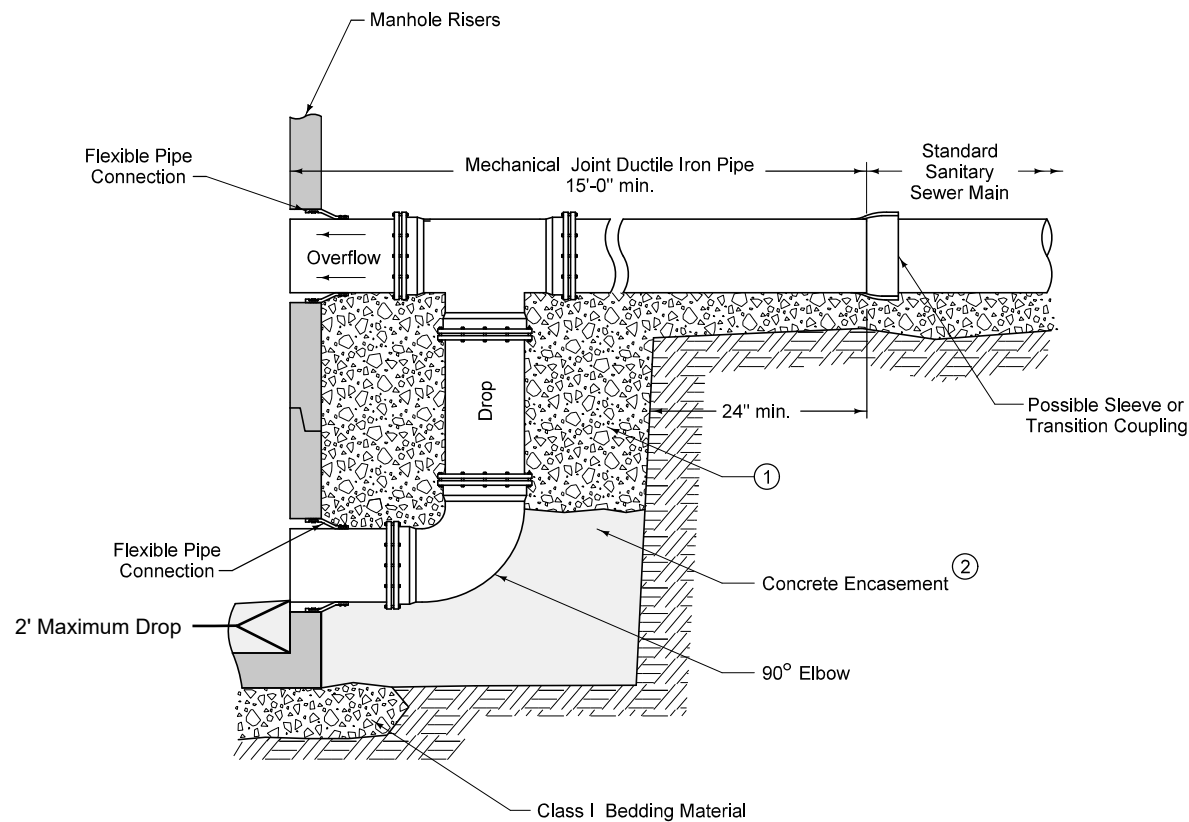
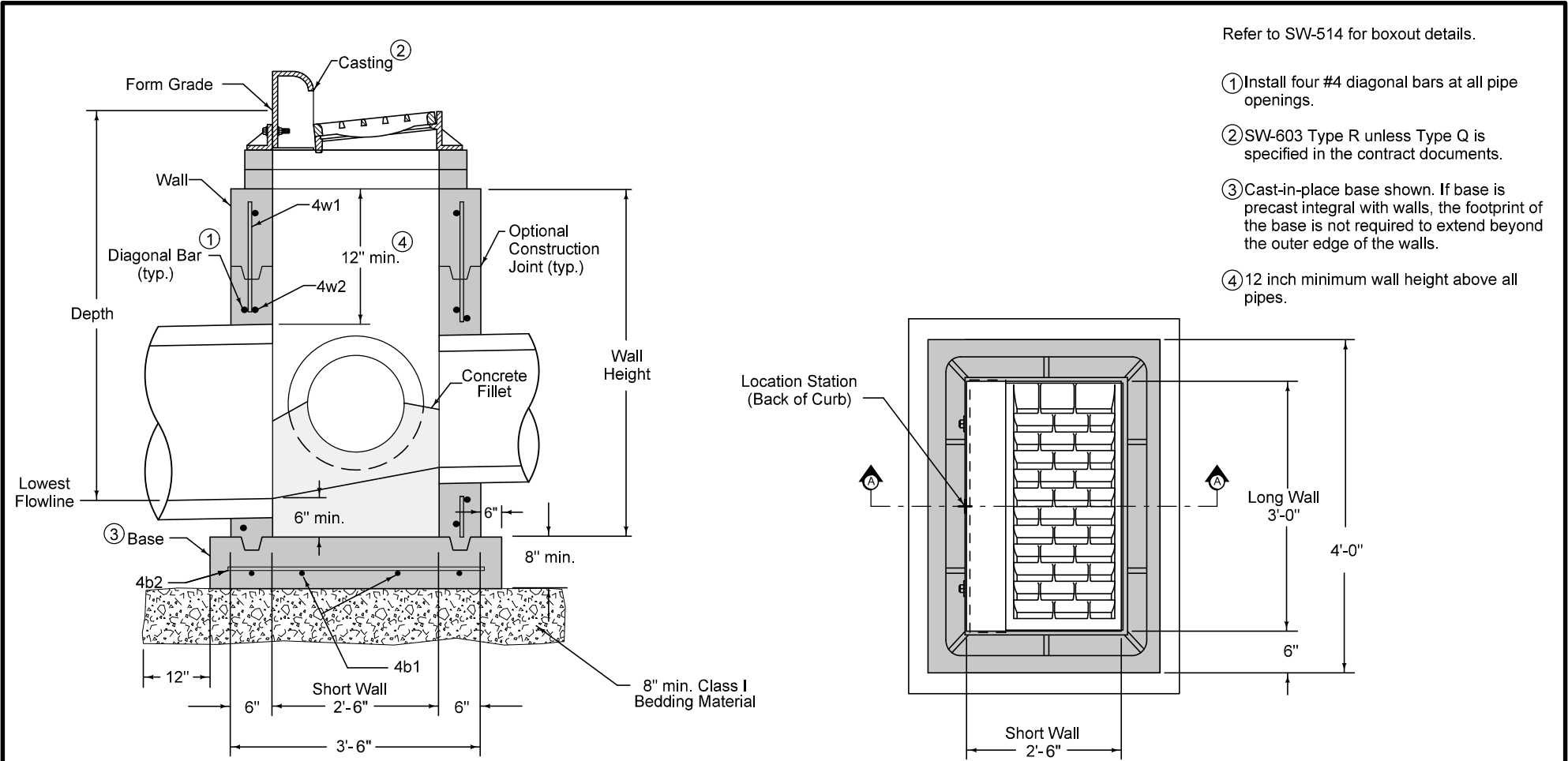

FIGURE 6010.307 SHEET 1 OF 1

	REVISION	
	1	05-22/25
STANDARD ROAD PLAN		BETT6010.307
		SHEET 1 of 1
REVISIONS:		
SUDAS DIRECTOR                      DESIGN METHODS ENGINEER		
EXTERNAL DROP CONNECTION FOR SANITARY SEWER MANHOLE		



Refer to SW-514 for boxout details.

- ① Install four #4 diagonal bars at all pipe openings.
- ② SW-603 Type R unless Type Q is specified in the contract documents.
- ③ Cast-in-place base shown. If base is precast integral with walls, the footprint of the base is not required to extend beyond the outer edge of the walls.
- ④ 12 inch minimum wall height above all pipes.

SECTION A-A

PLAN

REINFORCING BAR LIST						
Mark	Size	Location	Shape	Length	Count	Spacing
4w1	4	Walls	—	Wall Height minus 4"	14	12"
4w2	4	Long Walls	—	3'-8"	Varies	12"
4w3	4	Short Walls	—	3'-2"	Varies	12"
4b1	4	Base	—	4'-8"	4	10"
4b2	4	Base	—	4'-2"	5	10"

MAXIMUM PIPE DIAMETERS		
Pipe Location	Precast Structure	Cast-in-place Structure
Short Wall	15"	18"
Long Wall	24"	30"

FIGURE 6010.501 SHEET 1 OF 1

	REVISION	
	1	05-23/25
STANDARD ROAD PLAN		BETT6010.501
		SHEET 1 of 1
REVISIONS:		
SUDAS DIRECTOR		DESIGN METHODS ENGINEER
SINGLE GRATE INTAKE		

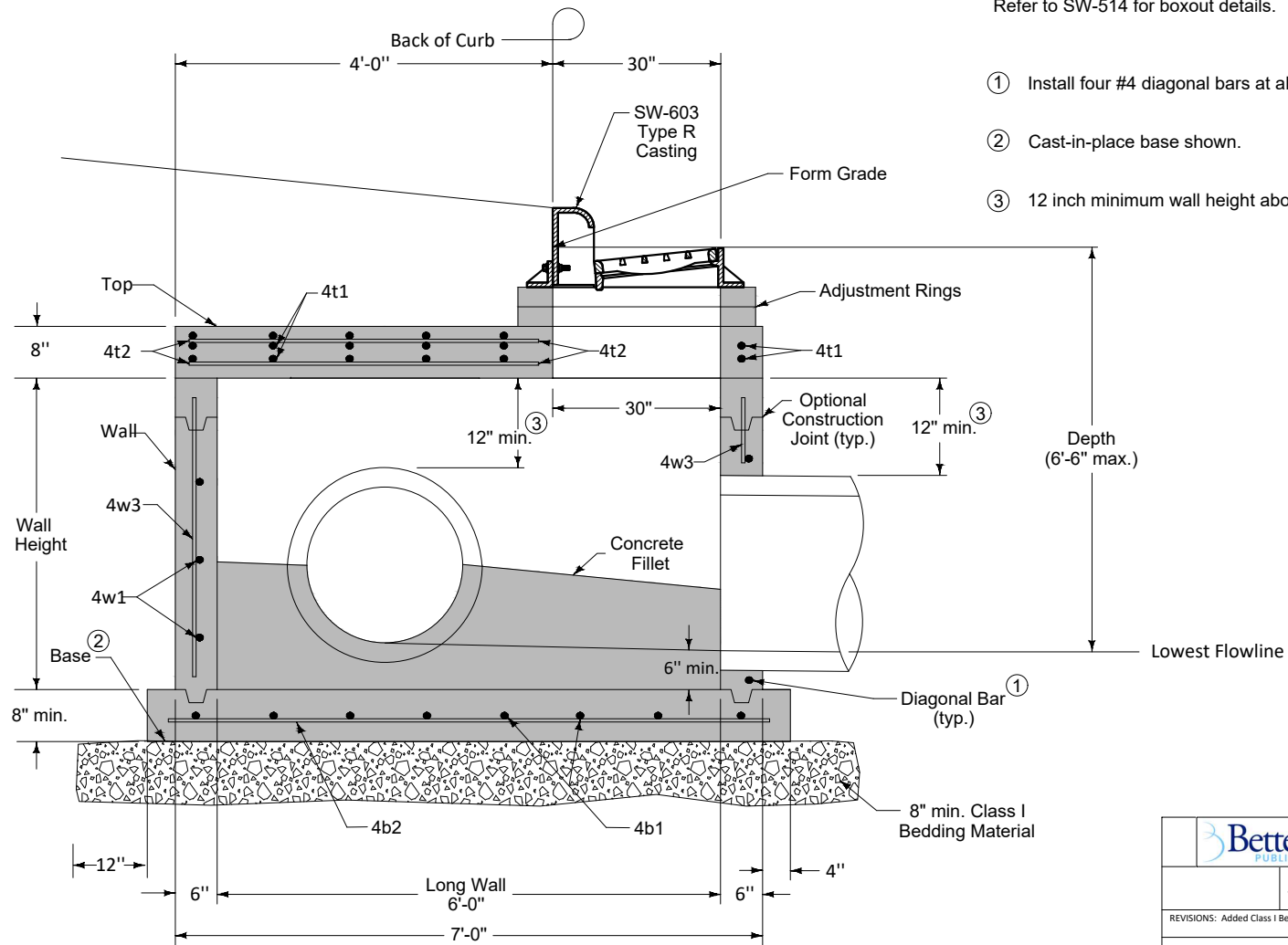

Refer to SW-514 for boxout details.

- ① Install four #4 diagonal bars at all pipe openings.
- ② Cast-in-place base shown.
- ③ 12 inch minimum wall height above all pipes.

TYPICAL SECTION

FIGURE 6010.503 SHEET 1 OF 2

	REVISION	
	1	05-23-25
	BETT6010.503	
STANDARD ROAD PLAN		
SHEET 1 of 2		
REVISIONS: Added Class I Bedding Material.		
SUDAS DIRECTOR		DESIGN METHODS ENGINEER
<p><b>SINGLE GRATE INTAKE</b></p> <p><b>SPECIAL</b></p>		

① Install four #4 diagonal bars at all pipe openings.

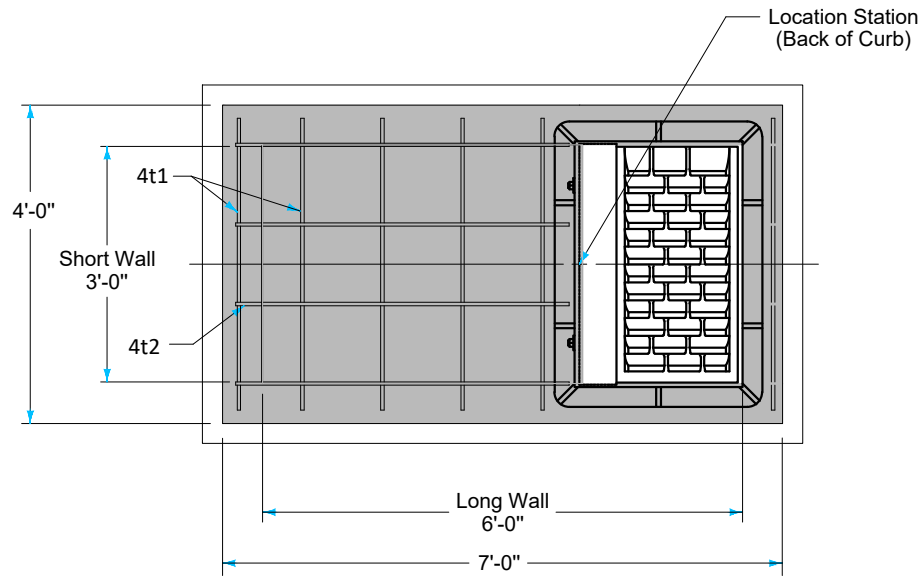

PLAN

REINFORCING BAR LIST						
Mark	Size	Location	Shape	Count	Length	Spacing
4t1	4	Top	—	12	3'-8"	12"
4t2	4	Top	—	8	4'-2"	12"
4b1	4	Base	—	7	4'-2"	13"
4b2	4	Base	—	5	7'-2"	10"
4w1	4	Short Walls	—	Varies	3'-8"	12"
4w2	4	Long Walls	—	Varies	6'-8"	12"
4w3	4	Walls	—	18	Wall Height minus 4"	13"

MAXIMUM PIPE DIAMETERS		
Pipe Location	Precast Structure	Cast-in-place Structure
Short Wall	24"	30"
Long Wall	30"	36"

	REVISION	
	1	05-23-25
STANDARD ROAD PLAN		BETT6010.503
		SHEET 1 of 2
REVISIONS: Added Class I Bedding Material.		
SUDAS DIRECTOR		DESIGN METHODS ENGINEER
<b>SINGLE GRATE INTAKE SPECIAL</b>		

FIGURE 6010.503 SHEET 2 OF 2

Refer to SW-514 for boxout details.

- ① Install four #4 diagonal bars at all pipe openings.
- ② Cast-in-place base shown. If base is precast integral with walls, the footprint of the base is not required to extend beyond the outer edge of the walls.
- ③ 12 inch minimum wall height above all pipes.

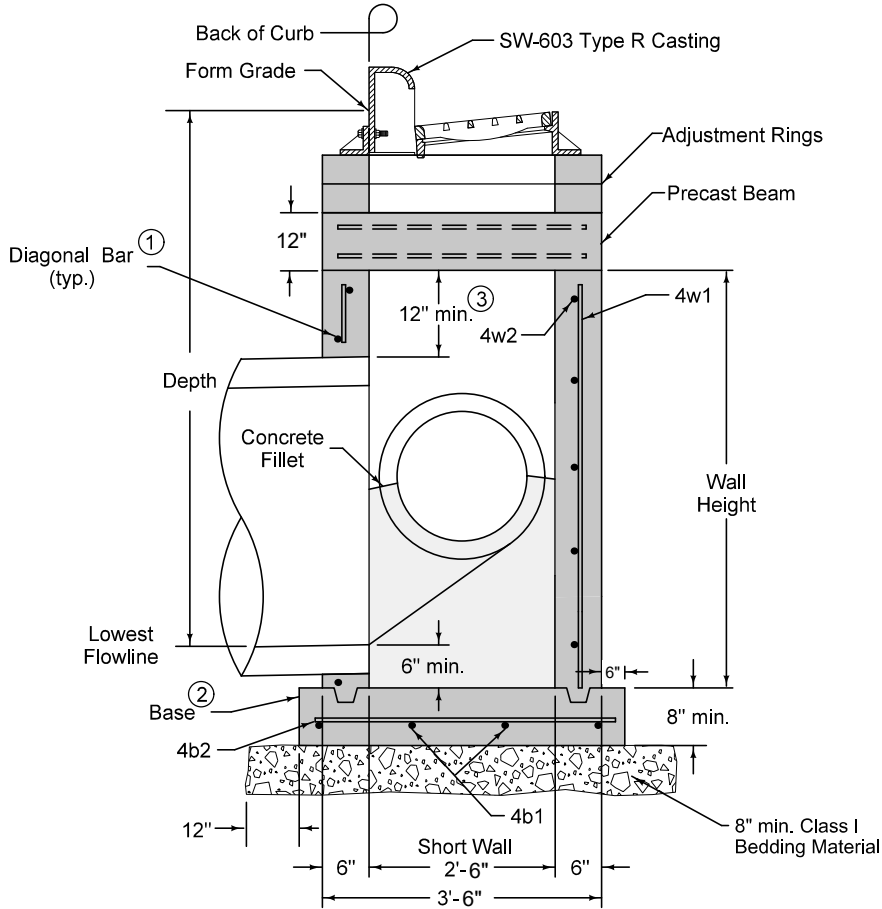

SECTION A-A

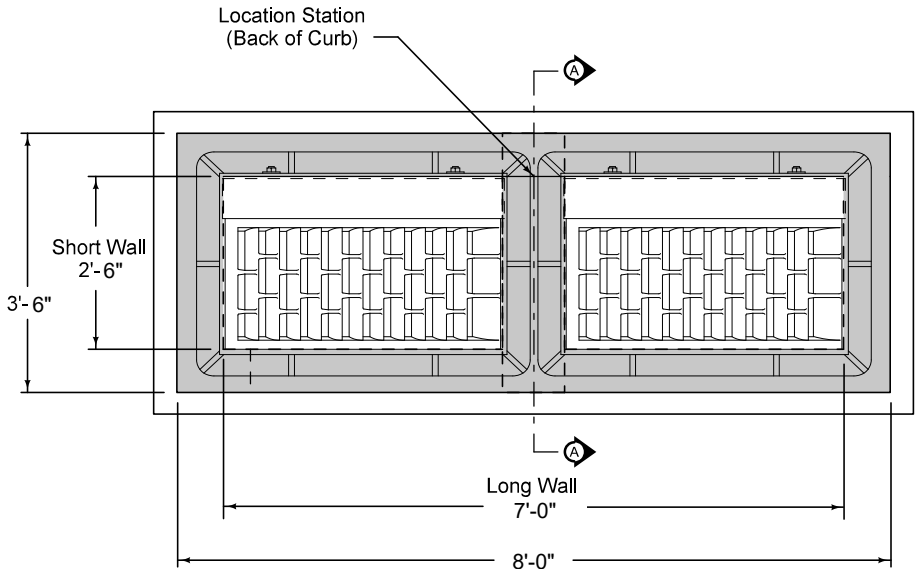

PLAN

FIGURE 6010.505 SHEET 1 OF 2

	STANDARD ROAD PLAN	REVISION 1 05-23/25
		BETT6010.505 SHEET 1 of 2
REVISIONS:		
SUDAS DIRECTOR	DESIGN METHODS ENGINEER	
<b>DOUBLE GRATE INTAKE</b>		

- ① Install four #4 diagonal bars at all pipe openings.
- ② Cast-in-place base shown. If base is precast integral with walls, the footprint of the base is not required to extend beyond the outer edge of the walls.
- ③ 12 inch minimum wall height above all pipes.

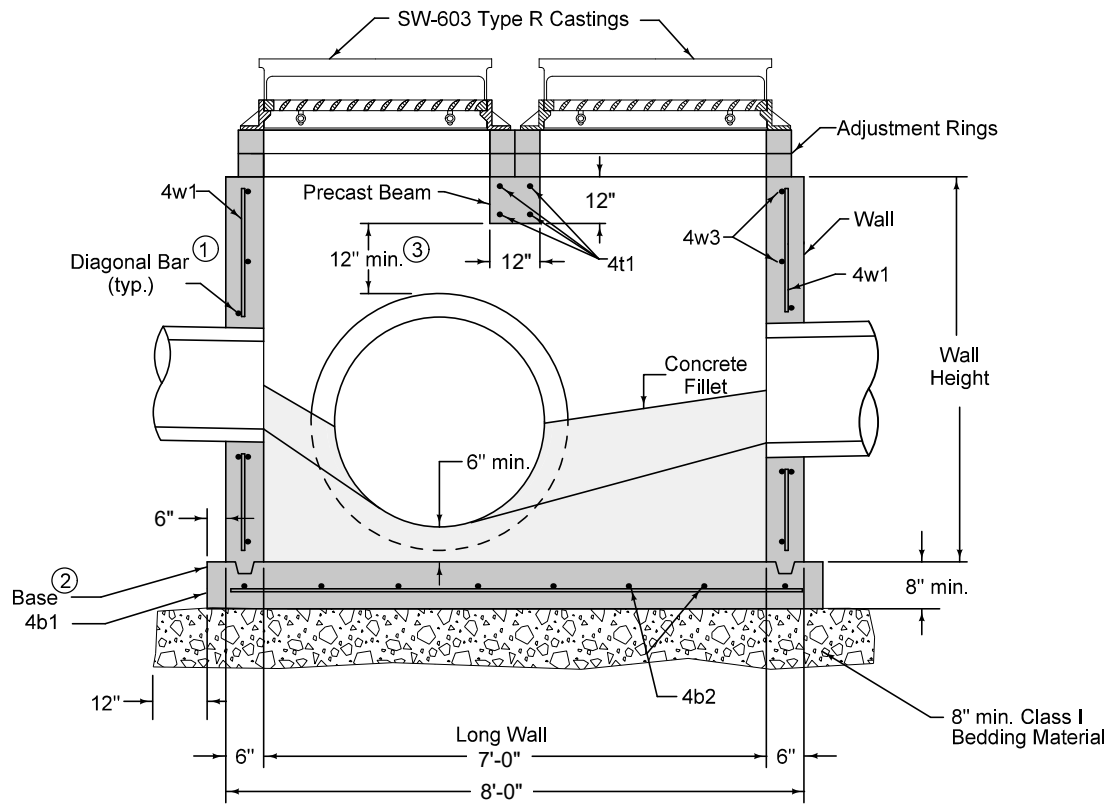

TYPICAL SECTION

REINFORCING BAR LIST

Mark	Size	Location	Shape	Count	Length	Spacing
4t1	6	Beam	—	4	3'-2"	4"
4b1	4	Base	—	4	8'-6"	10"
4b2	4	Base	—	8	3'-8"	12"
4w1	4	Walls	—	20	Wall Height minus 4"	12"
4w2	4	Long Walls	—	Varies	7'-8"	12"
4w3	4	Short Walls	—	Varies	3'-2"	12"

MAXIMUM PIPE DIAMETERS		
Pipe Location	Precast Structure	Cast-in-place Structure
Short Wall	18"	18"
Long Wall	60"	66"

FIGURE 6010.505 SHEET 2 OF 2

	REVISION	
	1	05-23/25
STANDARD ROAD PLAN		BETT6010.505
		SHEET 2 of 2
REVISIONS:		
<div style="display: flex; justify-content: space-between;"> <span>SUDAS DIRECTOR</span> <span>DESIGN METHODS ENGINEER</span> </div>		
DOUBLE GRATE INTAKE		

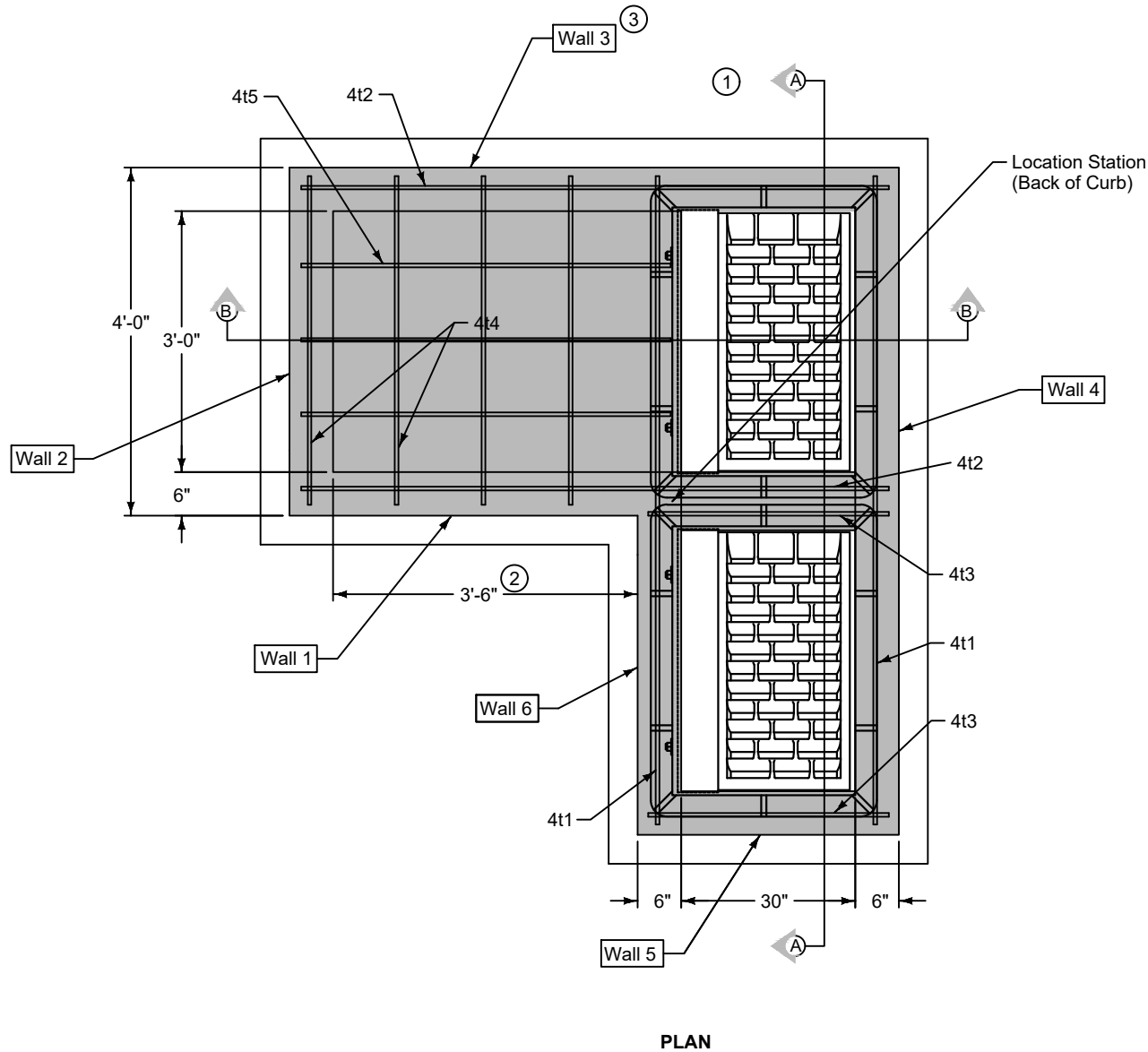

Maximum pipe diameters are set based on maximum structure depth of 6 feet-6 inches and the objective of placement of the centerline of the pipe on the centerline of the manhole opening for maintenance purposes.

Refer to SW-514 for boxout details.

- ① Install four #4 diagonal bars at manhole opening and at all pipe openings.
- ② If Wall 1 is widened to 4 feet, the maximum pipe diameter can be increased to 36 inches.
- ③ If Wall 1 is widened to 4 feet, the maximum pipe diameter in Wall 3 can be increased to 42 inches.

MAXIMUM PIPE DIAMETERS	
Wall	Max. Dia.
1	30" ②
2	24"
3	36" ③
4	42"

	REVISION	
	1	05-28-25
STANDARD ROAD PLAN		BETT6010.506
		SHEET 1 of 2
REVISIONS: Added Class I Bedding Material.		
SUDAS DIRECTOR		DESIGN METHODS ENGINEER
<b>DOUBLE GRATE INTAKE SPECIAL</b>		

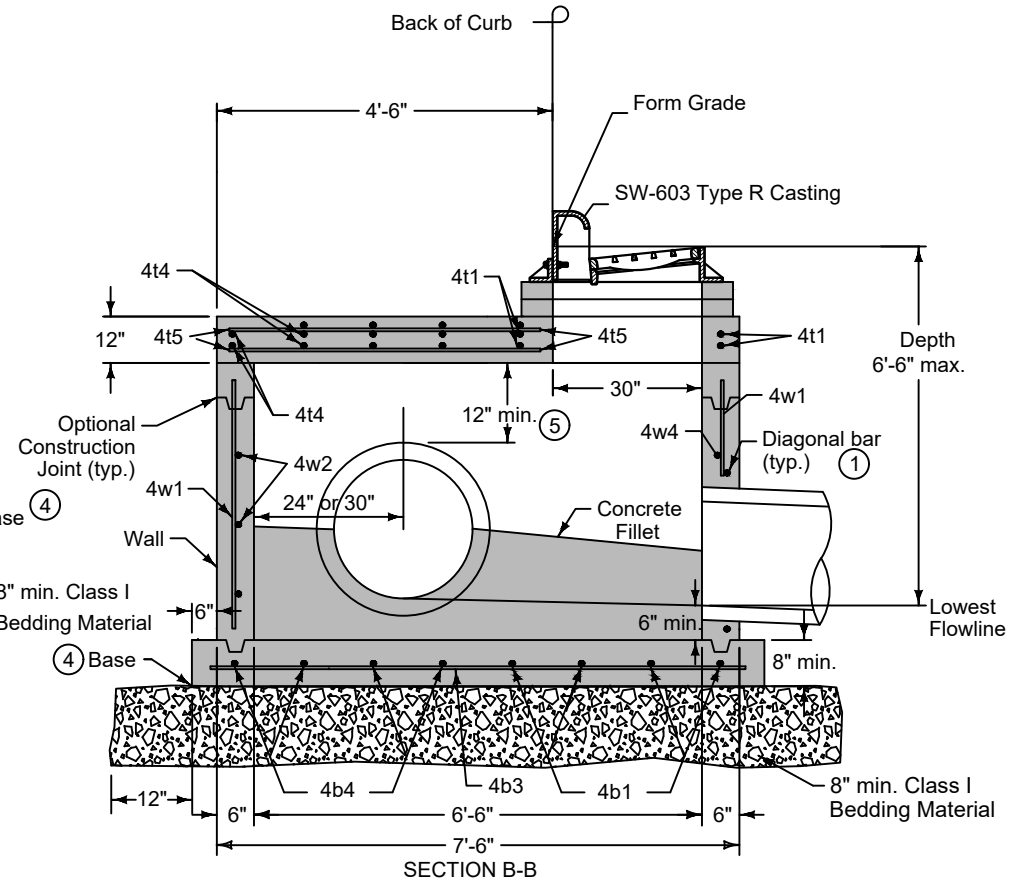
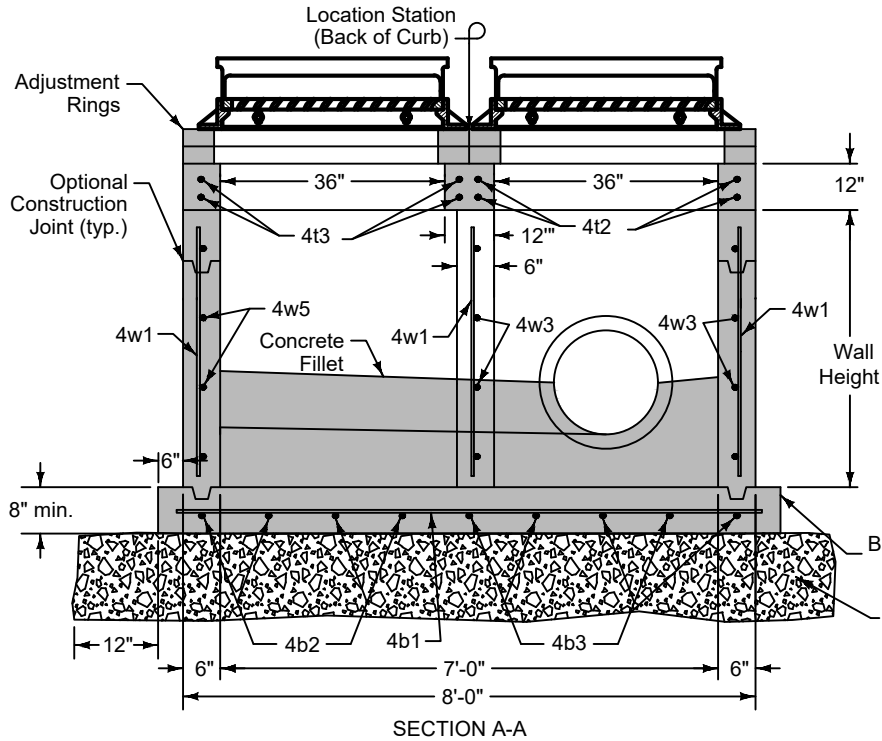

REINFORCING BAR LIST

Mark	Size	Location	Shape	Count	Length	Spacing
4t1	4	Top	—	4	7'-8"	See Detail
4t2	4	Top	—	4	7'-2"	See Detail
4t3	4	Top	—	4	3'-2"	See Detail
4t4	4	Top	—	8	3'-8"	12"
4t5	4	Top	—	6	4'-2"	12"
4b1	4	Base	—	4	8'-8"	12"
4b2	4	Base	—	4	3'-2"	12"
4b3	4	Base	—	5	8'-2"	12"
4b4	4	Base	—	4	4'-2"	12"
4w1	4	Walls	—	29	Wall Height minus 4"	12"
4w2	4	Wall 2	—	Varies	3'-8"	12"
4w3	4	Walls 1 and 3	—	Varies	7'-2"	12"
4w4	4	Wall 4	—	Varies	8'-8"	12"
4w5	4	Wall 5	—	Varies	3'-2"	12"
4w6	4	Wall 6	—	Varies	3'-10"	12"

- ① Install four #4 diagonal bars at all pipe openings.
- ④ Cast-in-place base shown.
- ⑤ 12 inch minimum wall height above all pipes.

FIGURE 6010.506

SHEET 2 OF 2

	REVISION
	1   05-28-25
STANDARD ROAD PLAN	BETT6010.506
SHEET 2 of 2	
REVISIONS: Added Class I Bedding Material.	
SUDAS DIRECTOR	DESIGN METHODS ENGINEER
<b>DOUBLE GRATE INTAKE SPECIAL</b>	

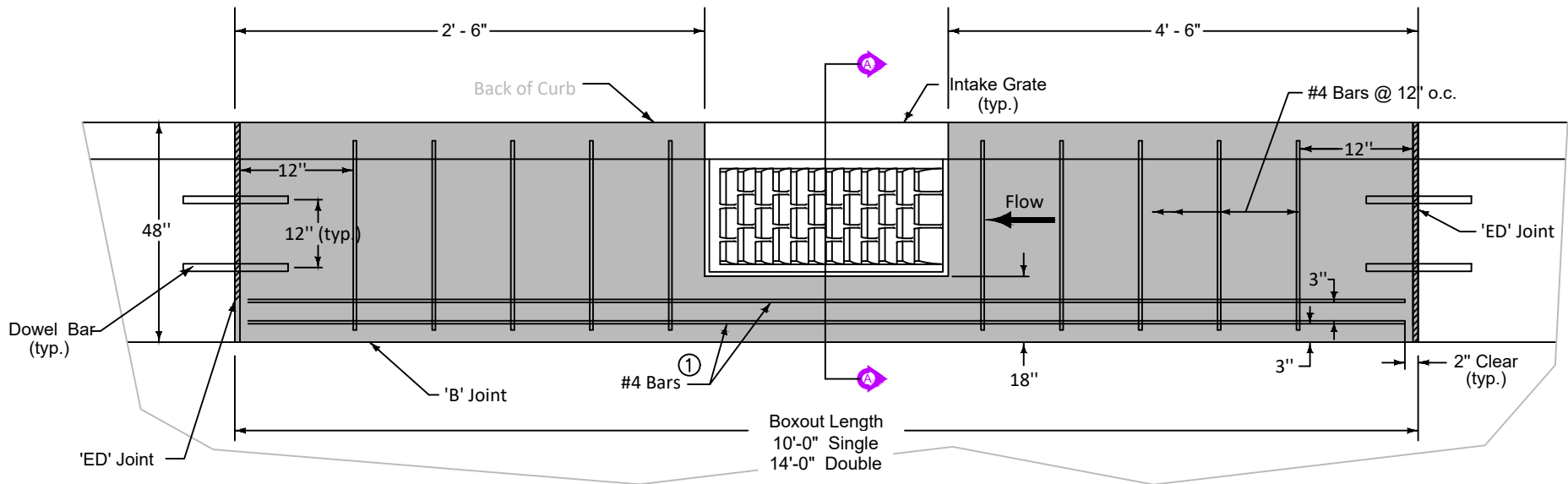

**BOXOUT IN PCC PAVEMENT AND PCC BASE WITH HMA OVERLAY**

Transverse joint spacing on new concrete pavement is controlled by the intake boxout. Adjust adjacent joint spacing as required to accommodate boxouts.

For retrofit intakes, match existing concrete pavement joints. Stop any transverse pavement joints that do not conform to the minimum spacing requirements at the edge of the boxout.

Contractor may add 2" to depth of pavement in lieu of steel reinforcement.

① Center bars vertically within slab.

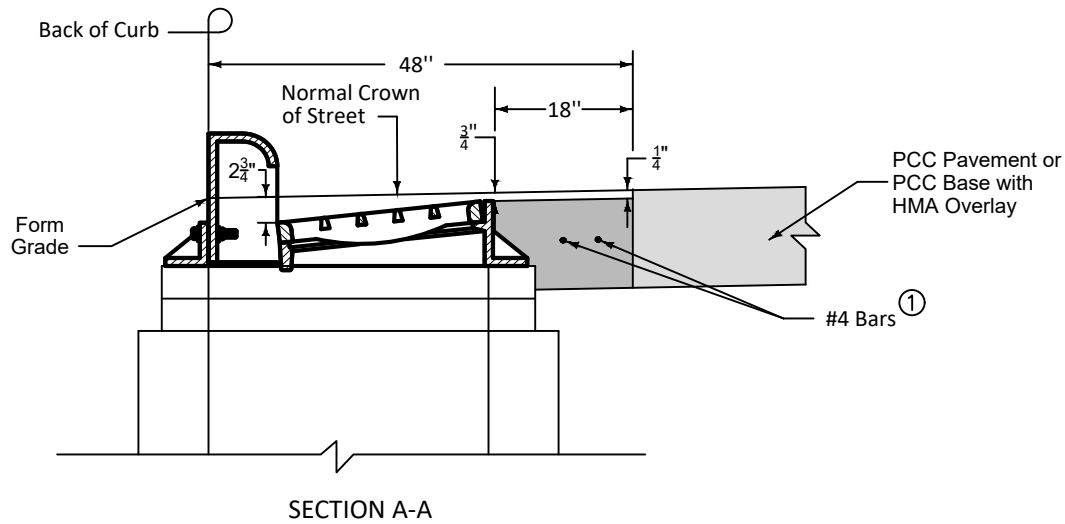

**SECTION A-A**

FIGURE BETT6010.514 SHEET 1 OF 2

	REVISION	
	1	05-28-25
STANDARD ROAD PLAN		BETT6010.514
		SHEET 1 of 2
REVISIONS: Added Class I Bedding Material.		
SUDAS DIRECTOR		DESIGN METHODS ENGINEER
<b>BOXOUT FOR GRATE INTAKES</b>		

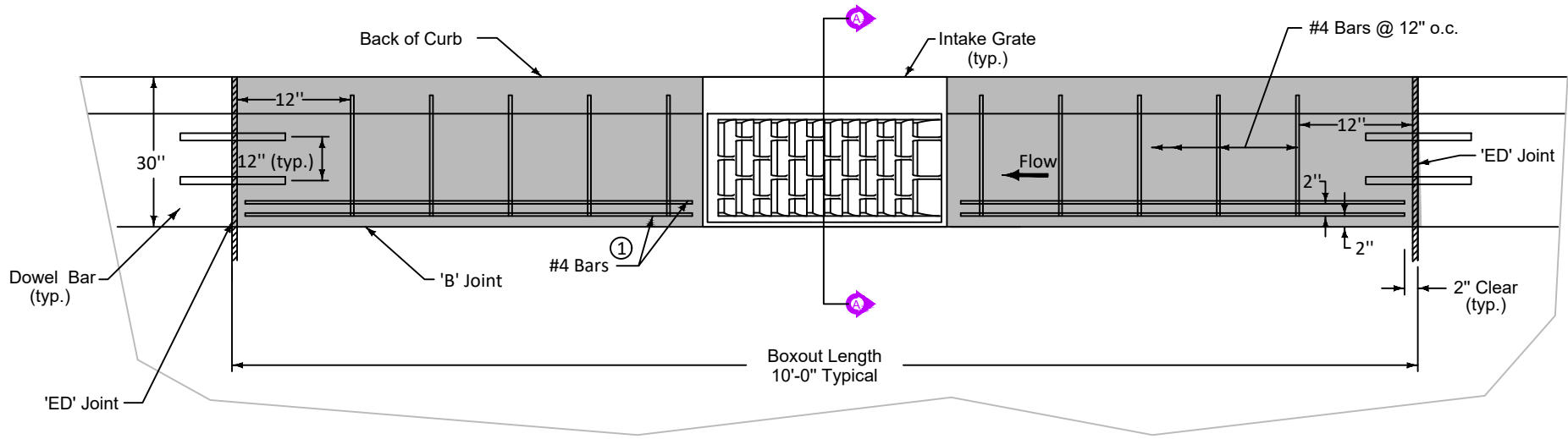

BOXOUT IN PCC CURB AND GUTTER

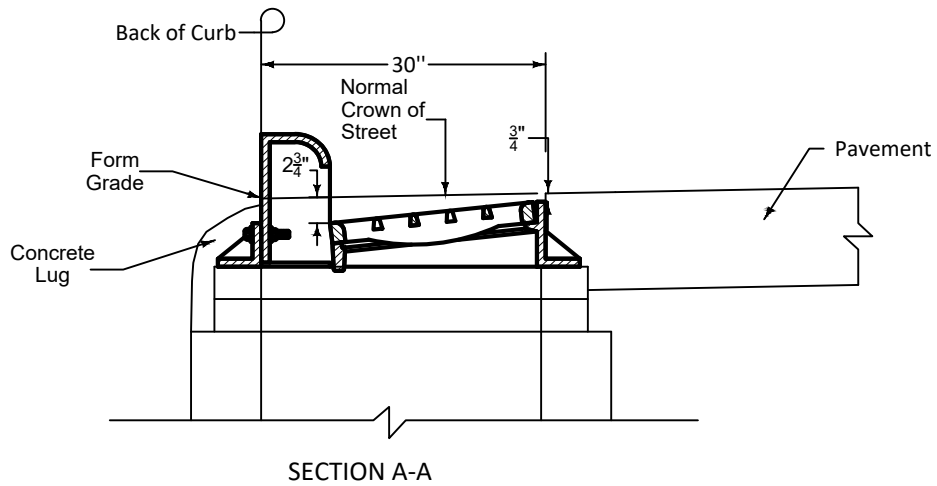

① Center bars vertically within slab.

FIGURE BETT6010.514 SHEET 2 OF 2

	REVISION	
	1	05-28-25
STANDARD ROAD PLAN		BETT6010.514
		SHEET 2 of 2
REVISIONS: Added Class I Bedding Material.		
SUDAS DIRECTOR		DESIGN METHODS ENGINEER
<b>BOXOUT FOR GRATE INTAKES</b>		

**NOTE:**

REINFORCING STEEL SHALL BE REQUIRED FOR PRECAST CONCRETE STRUCTURES SUFFICIENT TO INSURE THE ELIMINATION OF CRACKING PRIOR TO AND DURING PLACEMENT OF STRUCTURES AND TO MAINTAIN THE INTEGRITY OF THE STRUCTURE SHOULD CRACKING OCCUR AFTER CONSTRUCTION.

KEYWAYS SHALL HAVE NOMINAL DIMENSIONS OF 1 1/2" DEPTH AND 2 1/2" WIDTH.

LARGER DIAMETER BARS MAY BE SUBSTITUTED FOR #3 DEFORMED BARS.

MINIMUM STRUCTURE WALL THICKNESSES ARE:  
 5" FOR PRECAST CONCRETE  
 6" FOR POURED CONCRETE

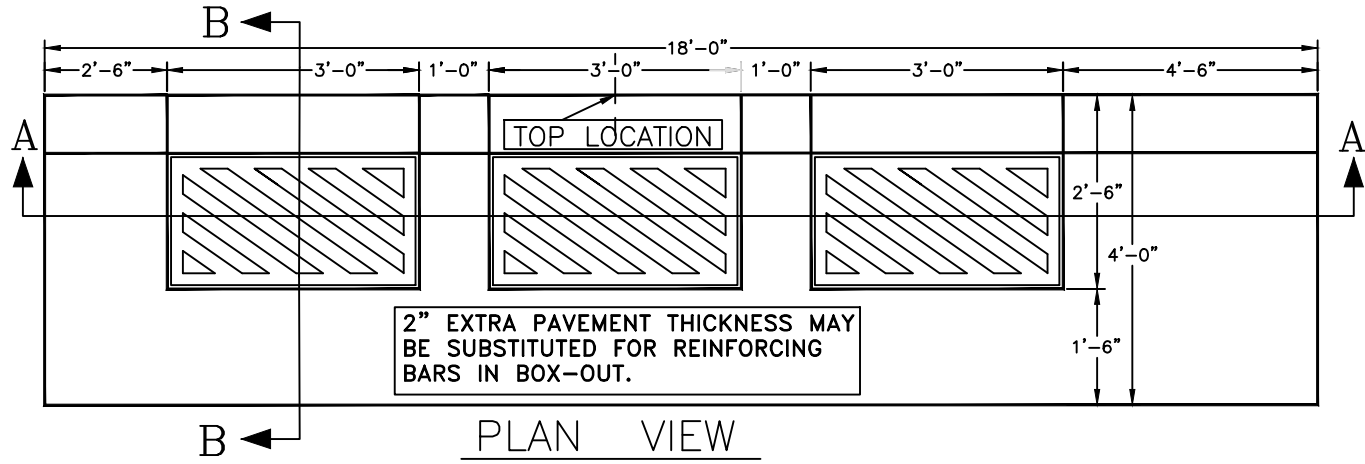

NEENAH R3246A FRAME WITH TYPE R GRATE OR TYPE L VANE GRATE, FLOW LEFT OR FLOW RIGHT OR EAST JORDAN IRON WORKS NO. 7510 WITH TYPE T4 BACK AND TYPE M5 (OR EQUAL) VANE STYLE GRATE OR EQUAL

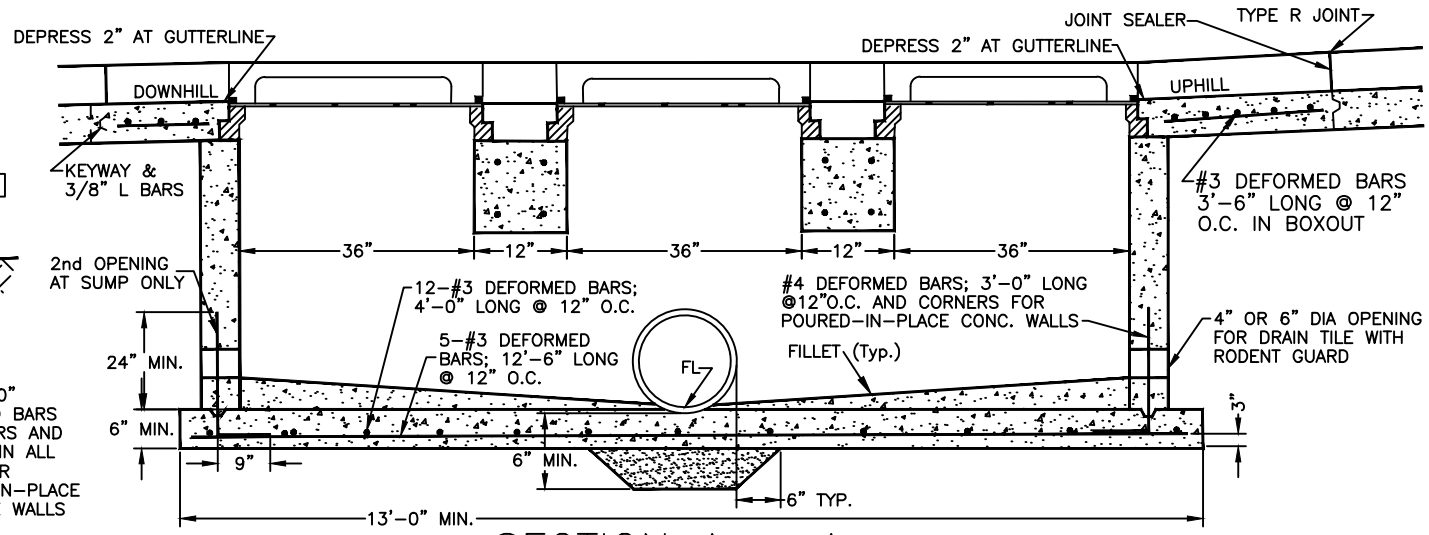

SECTION A - A

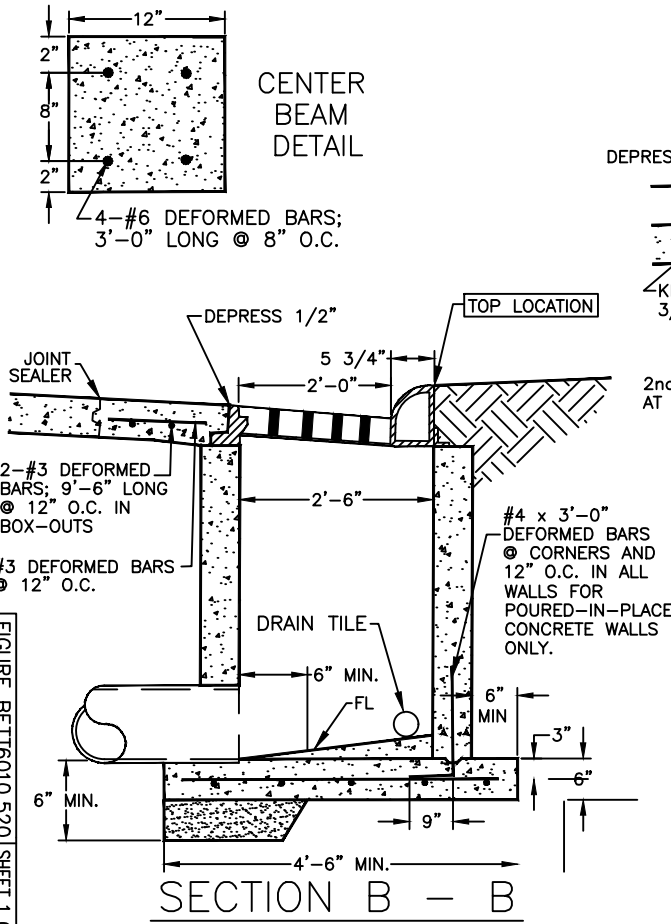

SECTION B - B

PRECAST BASES NOT ALLOWED

FIGURE BETT6010.520 SHEET 1 OF 1

	REVISION	1	09-15-25
	BETT6010.520		
	SHEET 1 of 1		
STANDARD ROAD PLAN			
REVISIONS:			
SUDAS DIRECTOR		DESIGN METHODS ENGINEER	
<b>TRIPLE CATCH BASIN</b>			

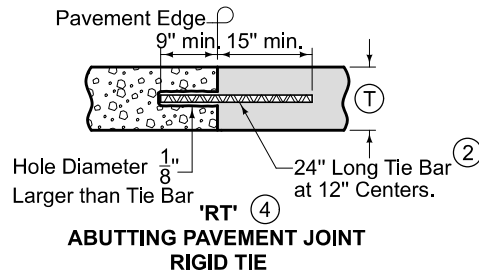
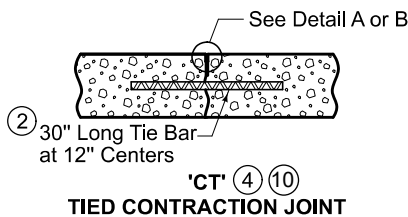
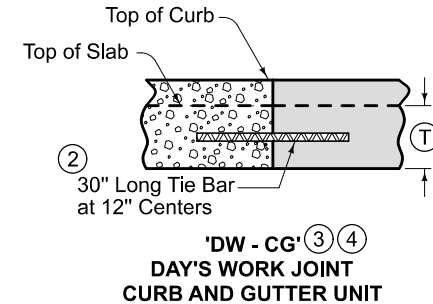
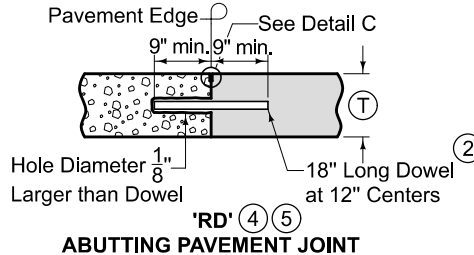
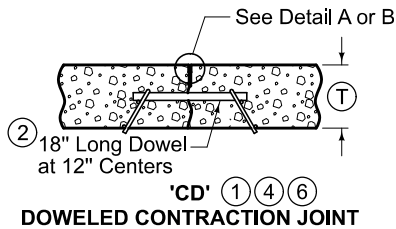
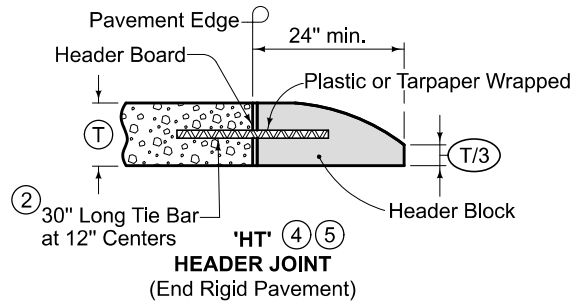
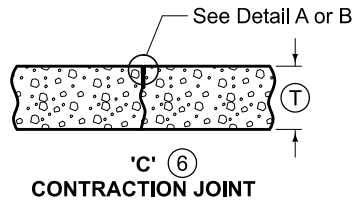
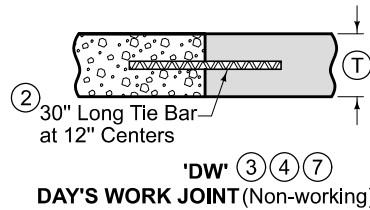
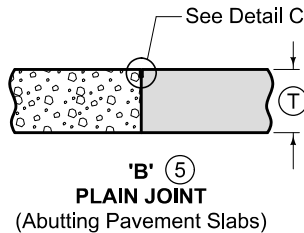

- ① See dowel assemblies for fabrication details.
- ② See Bar Size Table for Contraction Joints on Sheet 2.
- ③ Locate 'DW' joint at a mid-panel location between future 'C' or 'CD' joints. Place no closer than 5 feet to a 'C' or 'CD' joint.
- ④ Place bars within the limits shown under dowel assemblies.
- ⑤ Edge with 1/8 inch tool for length of joint. For HT joint, remove header block and board when second slab is placed.
- ⑥ Unless specified otherwise, use 'CD' transverse contraction joints in mainline pavement when (T) is greater or equal to 8 inches. Use 'C' joints when (T) is less than 8 inches.
- ⑦ 'RT' joint may be used in lieu of 'DW' joint at the end of the days work. Remove any pavement damaged due to the drilling at no additional cost to the Contracting Authority.

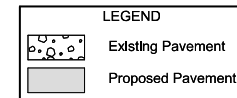

	REVISION
	12 09/10/25
	BETT7010.101
SHEET 1 of 8	

**TRANSVERSE CONTRACTION**

**JOINTS**

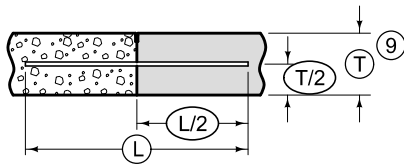

**BAR PLACEMENT**

(Applies to all joints unless otherwise detailed.)

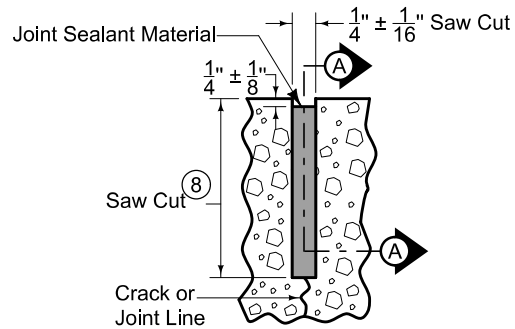

**DETAIL A**

(Saw cut formed by conventional concrete sawing equipment.)

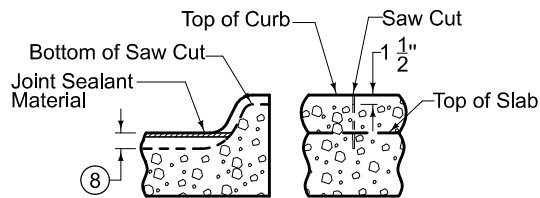

**'C' JOINT IN CURB**

(Match 'CT', 'CD', or 'C' joint in pavement.)

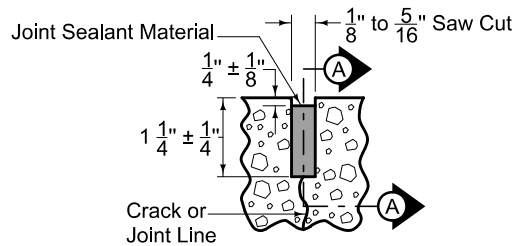

**DETAIL B**

(Saw cut formed by approved early concrete sawing equipment.)

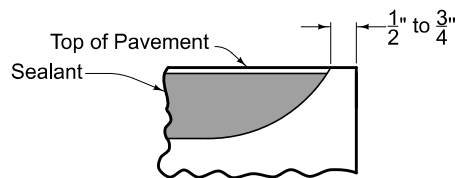

**SECTION A-A**

(Detail at Edge of Pavement)

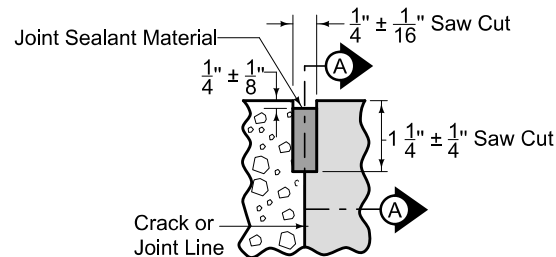

**DETAIL C**

- ⑧ Saw 'CD' joint to a depth of  $T/3 \pm 1/4"$ ; saw 'C' joint to a depth of  $T/4 \pm 1/4"$ .
- ⑨ When tying into old pavement, ① represents the depth of sound PCC.

**BAR SIZE TABLE FOR CONTRACTION JOINTS**

①	Solid Dowel Diameter	Tubular Dowel Diameter	Elliptical	Tie Bar Size
< 8"	3/4"	7/8"	N/A	#6
≥ 8" but < 10"	1 1/4"	1 3/8"	Small	#10
≥ 10"	1 1/2"	1 5/8"	Medium	#11

Tubular and Elliptical Dowel Bars will not be allowed for RD joints.

**LEGEND**

	Existing Pavement
	Proposed Pavement



REVISION	
12	09/10/25
BETT7010.101	
SHEET 2 of 8	

**TRANSVERSE CONTRACTION**

**JOINTS**

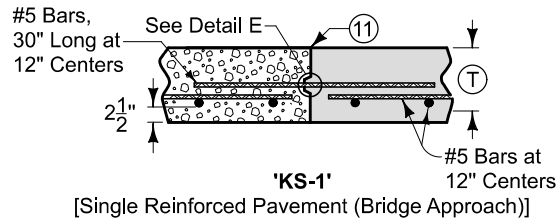
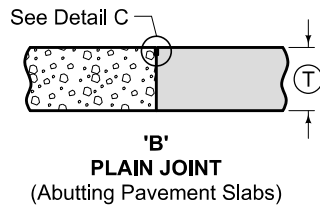

- ⑩ Bar supports shall be necessary for slip form paving to ensure the bar remains in a horizontal position in the plastic concrete.
- ⑪ Routing and sealing of joint is required.
- ⑫ The following joints are interchangeable, subject to the pouring sequence:  
'L-1', 'BT-1', and 'KT-1'  
'L-2', 'BT-2', and 'KT-2'  
'L-3', 'BT-6', and 'KT-3'

KT joints should not be used when DOT is contracting authority.

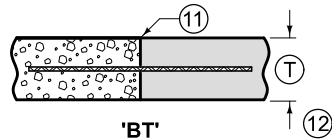

**'BT'**  
ABUTTING PAVEMENT JOINT - RIGID TIE

Ⓣ	Joint	Bars	Bar Length and Spacing
< 8"	'BT-1'	#4	36" Long at 30" Centers
		#5	30" Long at 30" Centers
≥ 8"	'BT-2'	#5	36" Long at 30" Centers
	'BT-6'	#5	36" Long at 15" Centers

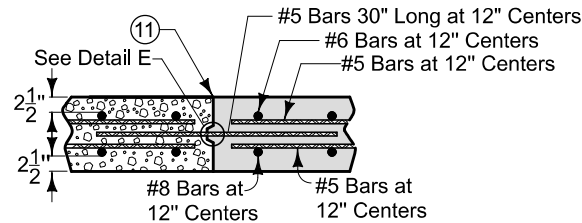

**'KS-2'**  
[Double Reinforced Pavement (Bridge Approach)]

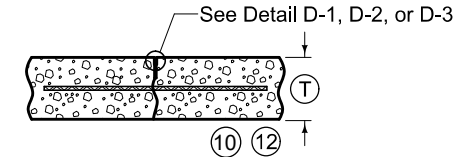

**'L'**  
CONTRACTION JOINT

Ⓣ	Joint	Bars	Bar Length and Spacing
< 8"	'L-1'	#4	36" Long at 30" Centers
≥ 8"	'L-2'	#5	36" Long at 30" Centers
	'L-3'		36" Long at 15" Centers

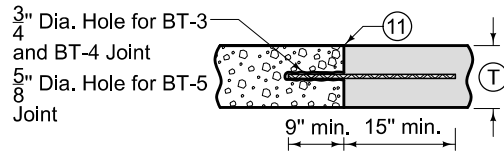

**'BT'**  
ABUTTING PAVEMENT JOINT - RIGID TIE (Drilled)

Ⓣ	Joint	Bars	Bar Length and Spacing
< 8"	'BT-5'	#4	24" Long at 30" Centers
≥ 8"	'BT-3'	#5	24" Long at 30" Centers
	'BT-4'		24" Long at 15" Centers

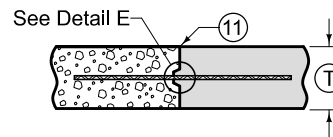

**'KT'**  
ABUTTING PAVEMENT JOINT - KEYWAY TIE

Ⓣ	Joint	Bars	Bar Length and Spacing
< 8"	'KT-1'	#4	30" Long at 30" Centers
≥ 8"	'KT-2'	#5	30" Long at 30" Centers
	'KT-3'		30" Long at 15" Centers

**LONGITUDINAL CONTRACTION**

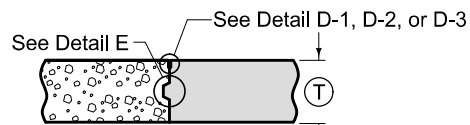

**'K'**  
KEYED JOINT FOR ADJACENT SLABS  
(Where T is 8" or more)

LEGEND

Existing Pavement

Proposed Pavement

**Bettendorf**  
PUBLIC WORKS

REVISION	
12	09/10/25

BETT7010.101  
SHEET 3 of 8

**JOINTS**

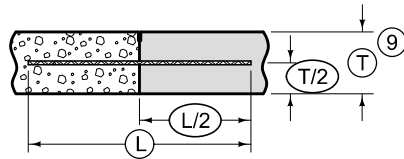

**TIE BAR PLACEMENT**  
(Applies to all joints unless otherwise detailed.)

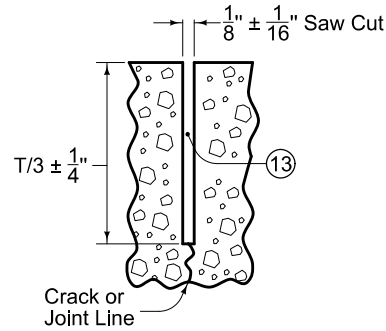

**DETAIL D-1**  
(Required when specified in the contract documents.)

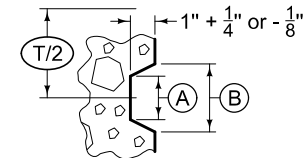

**DETAIL E**

- ⑨ When tying into old pavement, (T) represents the depth of sound PCC.
- ⑬ Sealant or cleaning not required.

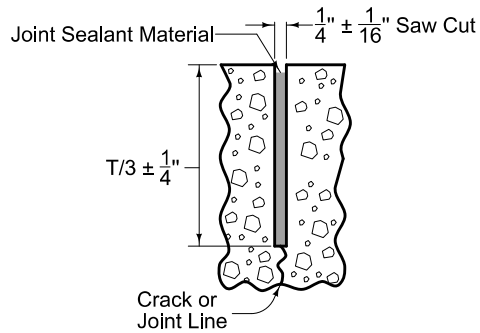

**DETAIL D-2**  
(Required when the Department of Transportation is not the Contracting Authority, or when specified in the contract documents)

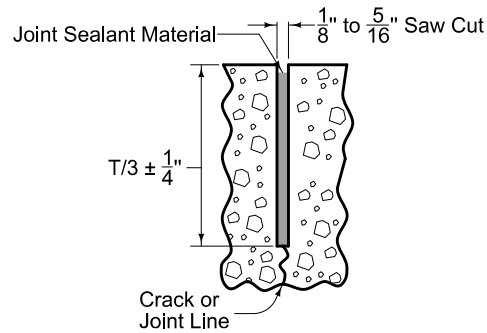

**DETAIL D-3**  
(Required when the Department of Transportation is the Contracting Authority, or when specified in the contract documents)

KEYWAY DIMENSIONS			
Keyway Type	Pavement Thickness (T)	(A)	(B)
Standard	8" or greater	1 3/4"	2 3/4"
Narrow	Less than 8"	1"	2"

LEGEND	
	Existing Pavement
	Proposed Pavement



REVISION	
12	09/10/25
BETT7010.101	
SHEET 4 of 8	

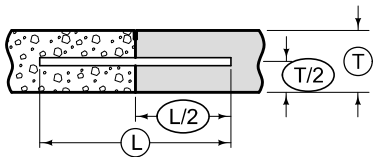

**DOWEL PLACEMENT**

(Applies to all joints unless otherwise detailed.)

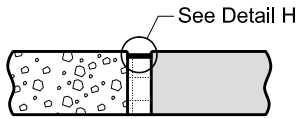

Width (See table below)  
**'CF' JOINT**

TYPE	WIDTH
CF-1	2"
CF-2	2 1/2"
CF-3	3"
CF-4	3 1/2"

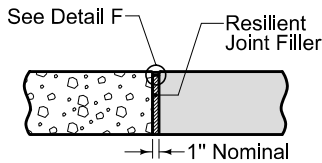

**'E' JOINT**  
**1" EXPANSION JOINT**

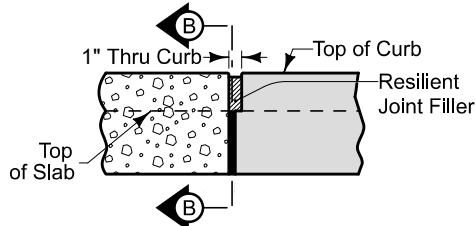

**'E' JOINT IN CURB**  
(View at Back of Curb)

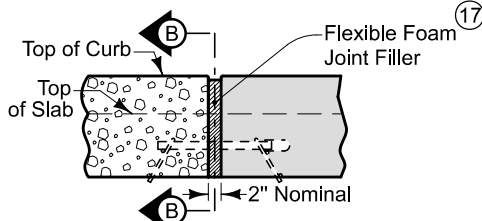

**'EE' JOINT IN CURB**  
(View at Back of Curb)

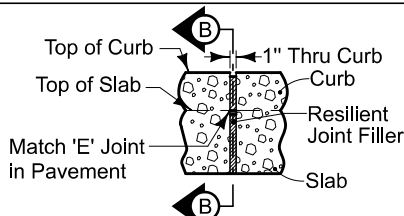

**'ES' JOINT IN CURB**  
(View at Back of Curb)

Detail F or Detail G (See Bar Size Table for Doweled Expansion Joints)  
Joint Filler Material (17) (See Bar Size Table for Doweled Expansion Joints)

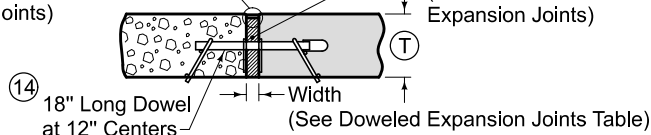

**'ED', 'EE', 'EF' (16) DOWELED EXPANSION JOINT**

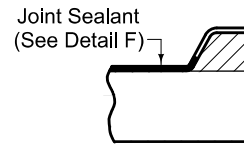

**SECTION B-B**

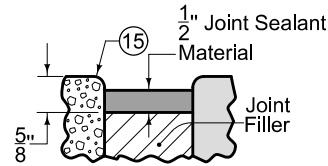

**DETAIL F**

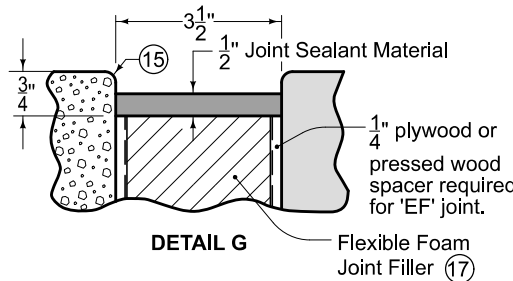

**DETAIL G**

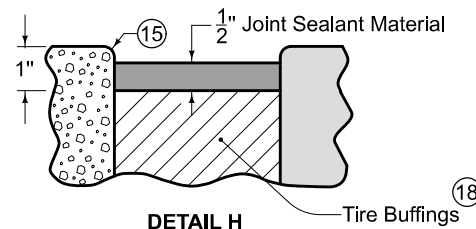

**DETAIL H**

**EXPANSION**

- (14) See Bar Size Table for Doweled Expansion Joints.
- (15) Edge with 1/4 inch tool for length of joint indicated if formed; edging not required when cut with diamond blade saw.
- (16) See Dowel Assemblies for fabrication details and placement limits. Coat the free end of dowel bar to prevent bond with pavement. At intake locations, dowel bars may be cast-in-place.
- (17) Predrill or preform holes in joint material for appropriate dowel size.
- (18) Compact tire buffings by spading with a square-nose shovel.

DOWELED EXPANSION JOINTS		
TYPE	WIDTH	FILLER MATERIAL (17)
ED	1"	Resilient (Detail F)
EE	2"	Flexible Foam (Detail F)
EF	3 1/2"	Flexible Foam (Detail G)

BAR SIZE TABLE FOR DOWELED EXPANSION JOINTS			
(T)	< 8"	≥ 8" but < 10"	≥ 10"
Dowel Diameter	3/4"	1 1/4"	1 1/2"

Tubular, GFRP, and Elliptical Dowel Bars will not be allowed for expansion joints.

LEGEND	
	Existing Pavement
	Proposed Pavement

**Bettendorf PUBLIC WORKS**

REVISION	
12	09/10/25

BETT7010.101  
SHEET 5 of 8

**JOINTS**

**CONTRACTION JOINTS**

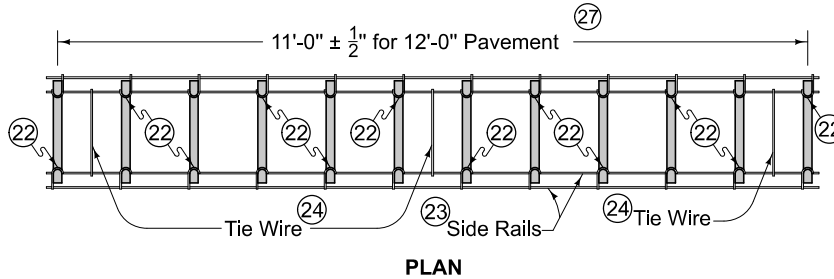

Spaces between dowel bars are nominal dimensions with a  $\frac{1}{4}$ " allowable tolerance.

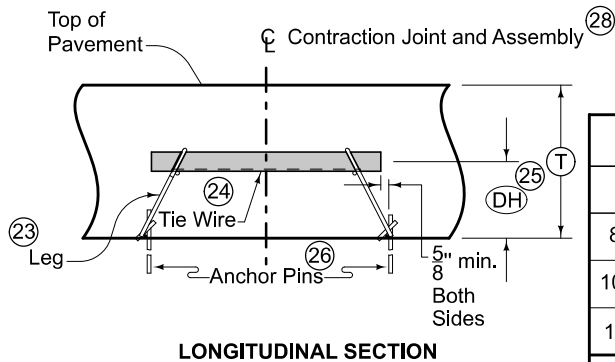
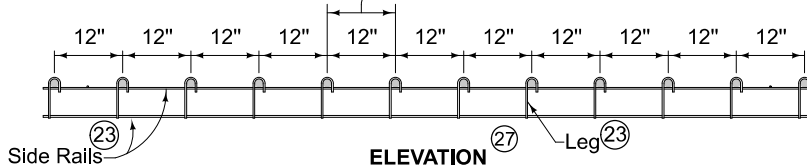

**LONGITUDINAL SECTION**

**DOWEL ASSEMBLIES**

DOWEL HEIGHT AND DIAMETER FOR DOWELED CONTRACTION JOINTS				
(T)	(DH) (25)	Diameter (Solid)	Diameter (Tubular)	Elliptical
8" to 9 $\frac{1}{2}$ "	4 $\frac{1}{4}$ "	1 $\frac{1}{4}$ "	1 $\frac{3}{8}$ "	Small
10" to 11 $\frac{1}{2}$ "	5 $\frac{1}{4}$ "	1 $\frac{1}{2}$ "	1 $\frac{5}{8}$ "	Medium
12" to 13"	6 $\frac{1}{4}$ "	1 $\frac{1}{2}$ "	1 $\frac{5}{8}$ "	Medium

Tubular, Elliptical Dowel Bars will not be allowed for RD joints.

- (19) Use 18 inch long dowel bars with a tolerance of  $\pm 1/8$  inch. Ensure the centerlines of individual dowels are parallel to the other dowels in the assembly within  $\pm 1/8$  inch.
- (20) Use wires with a minimum tensile strength of 50 ksi.
- (21) Details apply to both transverse contraction and expansion joints.
- (22) Weld alternately throughout.
- (23) 0.306 inch diameter wire. Wire sizes shown are the minimum required.
- (24) Maximum 0.177 inch diameter wire, welded or friction fit to upper side rail, both sides.
- (25) Measured from the centerline of dowel bar to bottom of lower side rail + 1/4 inch.
- (26) Per lane width, install a minimum of 8 anchor pins evenly spaced (4 per side), to prevent movement of assembly during construction. Anchor assemblies placed on pavement or PCC base with devices approved by the Engineer.
- (27) If dowel basket assemblies are required for curbed pavements, the assembly length is based on the jointing layout. See PV-101, sheet 8.
- (28) Ensure dowel basket assembly centerline is within 2 inches of the intended joint location longitudinally and has no more than 1/4 inch horizontal skew from end of basket to end of basket.

	REVISION
	12 09/10/25
	BETT7010.101
SHEET 6 of 8	
JOINTS	

**EXPANSION JOINTS**

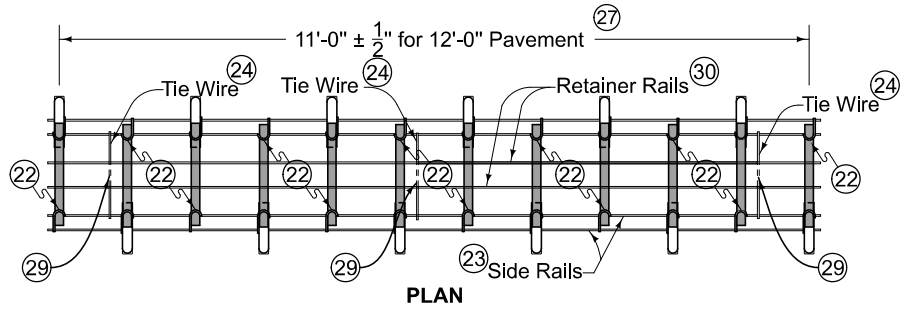

**PLAN**

Spaces between dowel bars are nominal dimensions with a 1/4" allowable tolerance.

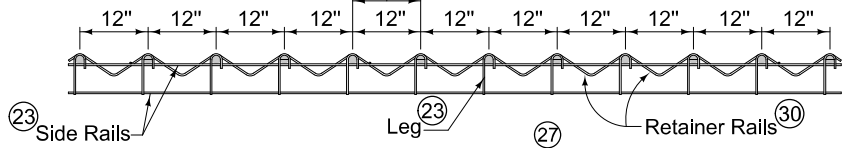

**ELEVATION**

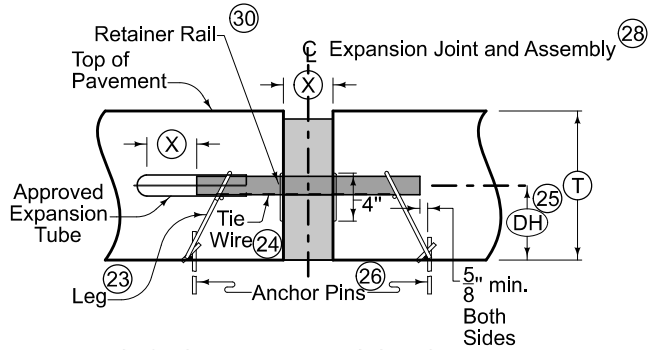

**SECTION THRU EXPANSION JOINT**

**DOWEL HEIGHT AND DIAMETER FOR DOWELED EXPANSION JOINTS**

T	DH (25)	Diameter
8" to 9 1/2"	4 1/4"	1 1/4"
10" to 11 1/2"	5 1/4"	1 1/2"
12" to 13"	6 1/4"	1 1/2"

Tubular, GFRP, and Elliptical Dowel Bars will not be allowed for expansion joints.

JOINT OPENING AND EXPANSION TUBE EXTENSION		
Joint Type	X	Minimum Tube Length
"ED"	1"	6"
"EE"	2"	7"
"EF"	3 1/2"	9"

**DOWEL ASSEMBLIES**

(19) (20) (21)

- (19) Use 18 inch long dowel bars with a tolerance of ± 1/8 inch. Ensure the centerlines of individual dowels are parallel to the other dowels in the assembly within ± 1/8 inch.
- (20) Use wires with a minimum tensile strength of 50 ksi.
- (21) Details apply to both transverse contraction and expansion joints.
- (22) Weld alternately throughout.
- (23) 0.306 inch diameter wire. Wire sizes shown are the minimum required.
- (24) Maximum 0.177 inch diameter wire, welded or friction fit to upper side rail, both sides.
- (25) Measured from the centerline of dowel bar to bottom of lower side rail + 1/4 inch.
- (26) Per lane width, install a minimum of 8 anchor pins evenly spaced (4 per side), to prevent movement of assembly during construction. Anchor assemblies placed on pavement or PCC base with devices approved by the Engineer.
- (27) If dowel basket assemblies are required for curbed pavements, the assembly length is based on the jointing layout. See PV-101, sheet 8.
- (28) Ensure dowel basket assembly centerline is within 2 inches of the intended joint location longitudinally and has no more than 1/4 inch horizontal skew from end of basket to end of basket.
- (29) Clip and remove center portion of tie during field assembly.
- (30) 1/4 inch diameter wire.

FIGURE 7010.101 SHEET 7 OF 8

	REVISION	
	12	09/10/25
	BETT7010.101	
SHEET 7 of 8		
<p><b>JOINTS</b></p>		

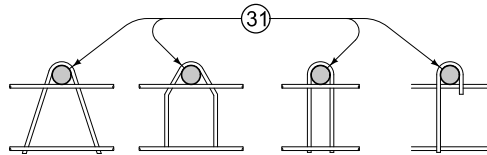

**OPTIONAL LEG SHAPES**

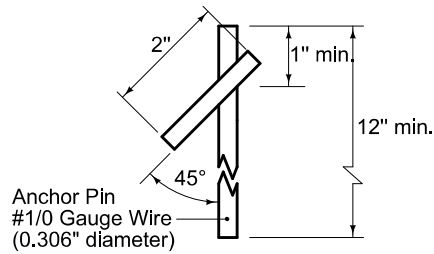

**ANCHOR PIN**

- ①9 Use 18 inch long dowel bars with a tolerance of  $\pm 1/8$  inch. Ensure the centerlines of individual dowels are parallel to the other dowels in the assembly within  $\pm 1/8$  inch.
- ②0 Use wires with a minimum tensile strength of 50 ksi.
- ②1 Details apply to both transverse contraction and expansion joints.
- ③1 Diameter of bend around dowel is dowel diameter +  $1/8$  to  $3/16$  inches.
- ③2 For uniform lane widths: 3 to 6 inches. For taper and variable width pavements: 3 to 12 inches.

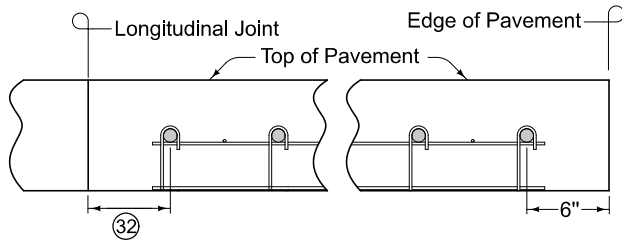

**PLACEMENT LIMITS  
(Rural Section)**

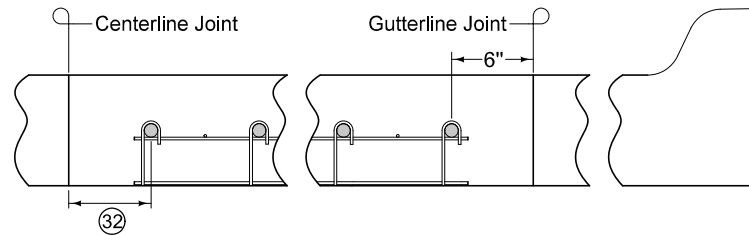

**PLACEMENT LIMITS  
(Curb and Gutter - Gutterline Jointing)**

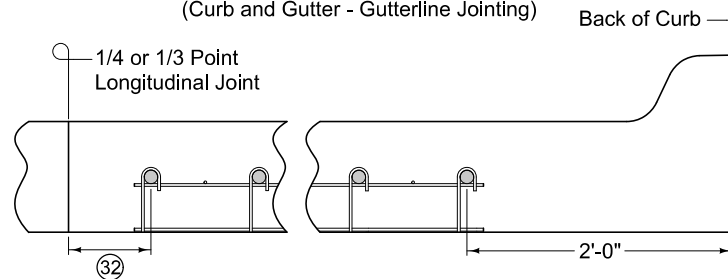

**PLACEMENT LIMITS  
(Curb and Gutter - 1/4 or 1/3 Point Jointing)**

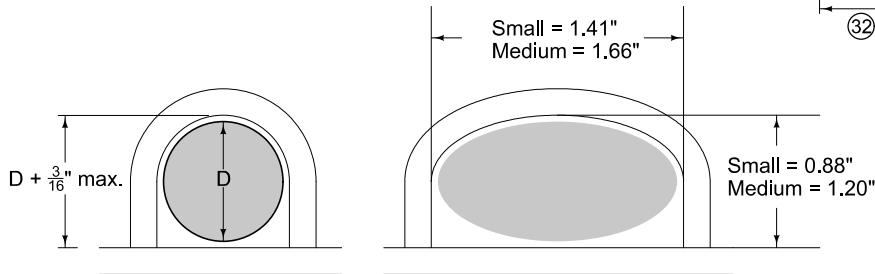

**BEND AROUND DOWEL**

**DOWEL ASSEMBLIES** ①9 ②0 ②1

	REVISION	
	12	09/10/25
	BETT7010.101	
SHEET 8 of 8		

**JOINTS**

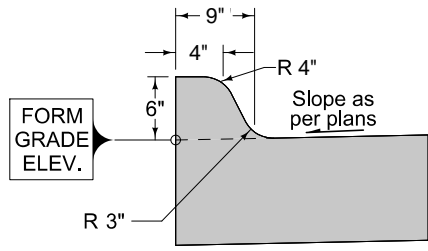

**6" STANDARD CURB**

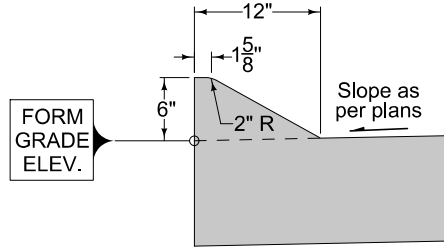

**6" SLOPED CURB**

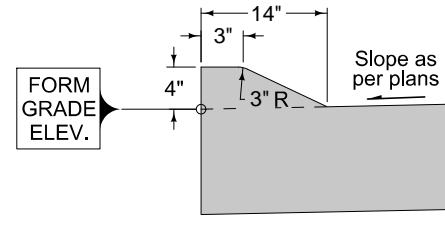

**4" SLOPED CURB**

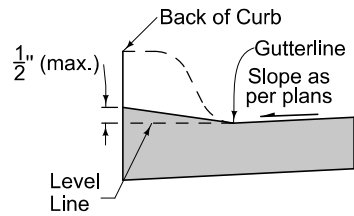

**DROP CURB AT SIDEWALK**

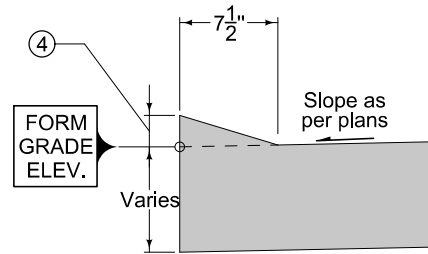

**DRIVEWAY DROP CURB**  
(Iowa Department of Transportation is not the Contracting Authority)

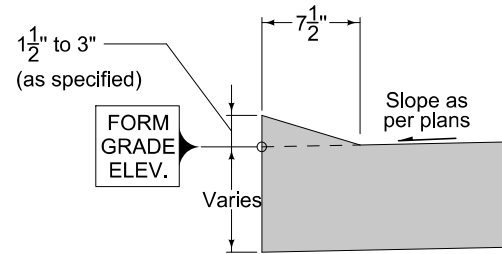

**DRIVEWAY DROP CURB**  
(Iowa Department of Transportation is the Contracting Authority)

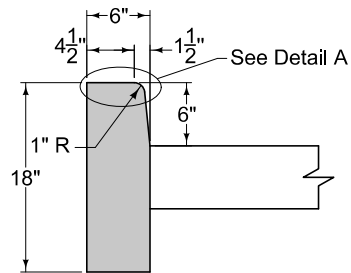

**BEAM CURB\***

\*For short replacement sections, match existing curb profile

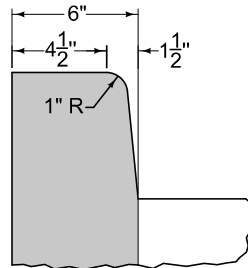

**DETAIL A**

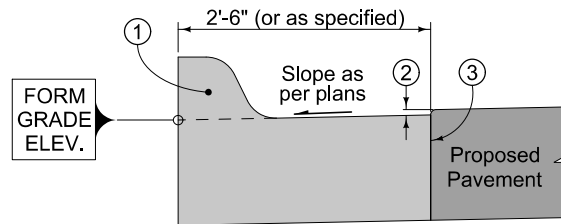

**CURB AND GUTTER UNIT**

For joint details, see PV-101.

- ① 6 inch Standard Curb, 6 inch Sloped Curb, or 4 inch Sloped Curb as specified.
- ② 1/8 inch if Proposed Pavement is HMA. No elevation difference if Proposed Pavement is PCC.
- ③ 'BT', 'KT', or 'L' joint if Proposed Pavement is PCC. 'B' joint if Proposed Pavement is HMA.
- ④ 0 to 2 inches for residential entrances. 1 1/2 to 3 inches for industrial or commercial entrances.

FIGURE 7010.102 SHEET 1 OF 2

	REVISION
	1 05-23/25
STANDARD ROAD PLAN	BETT7010.102
	SHEET 1 of 2

REVISIONS:	
SUDAS DIRECTOR	DESIGN METHODS ENGINEER

**PCC CURB DETAILS**

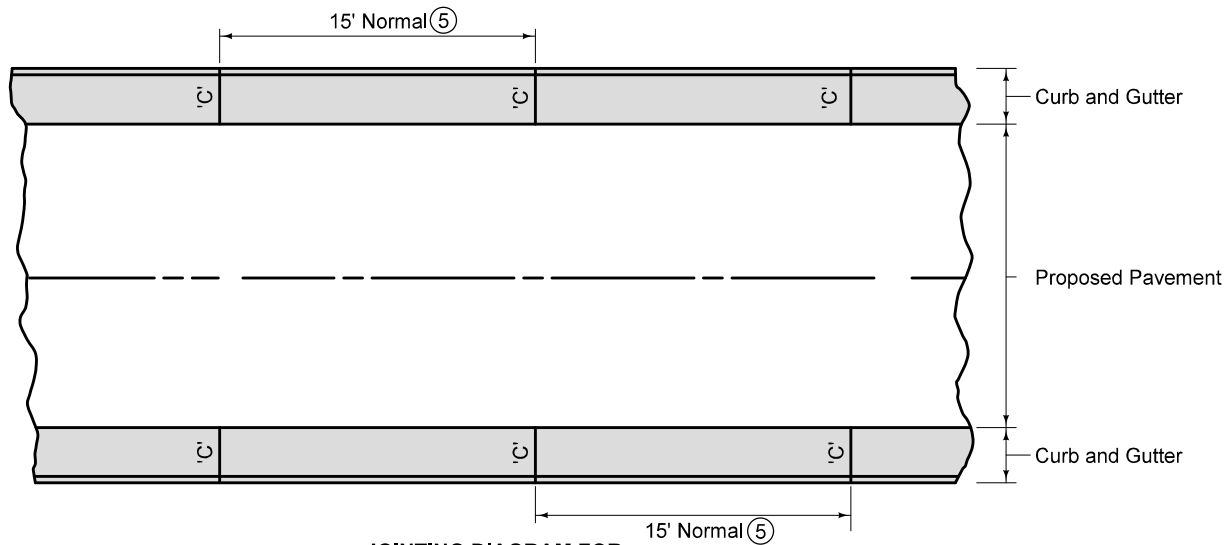

**JOINTING DIAGRAM FOR CURB AND GUTTER UNIT**

⑤ If proposed pavement is PCC, match joint spacing for proposed pavement. Place 'E' joints in curb and gutter section where expansion joints are to be placed in proposed pavement.

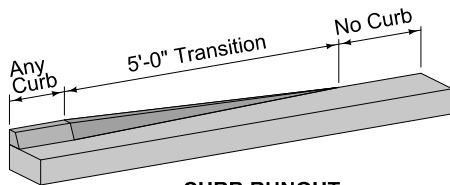

**CURB RUNOUT FOR ALL CURBS**

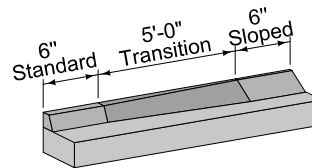

**CURB TRANSITION FROM 6" STANDARD TO 6" SLOPED**

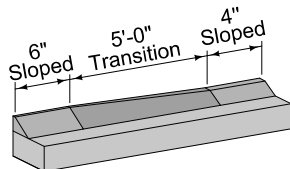

**CURB TRANSITION FROM 6" SLOPED TO 4" SLOPED**

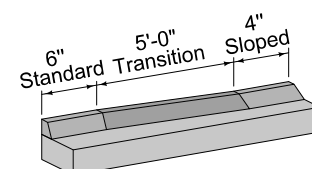

**CURB TRANSITION FROM 6" STANDARD TO 4" SLOPED**

FIGURE 7010.102

SHEET 2 OF 2

	REVISION	05-23/25
	1	
STANDARD ROAD PLAN		BETT7010.102
REVISIONS:		SHEET 2 of 2

SUDAS DIRECTOR	DESIGN METHODS ENGINEER
----------------	-------------------------

**PCC CURB DETAILS**

NOTE: CONTRACTOR MAY ADD 2" TO DEPTH OF PAVEMENT IN LIEU OF STEEL REINFORCEMENT.

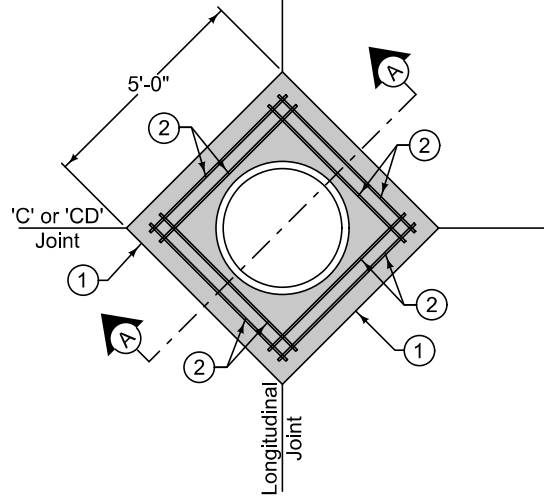

AT JOINT INTERSECTION

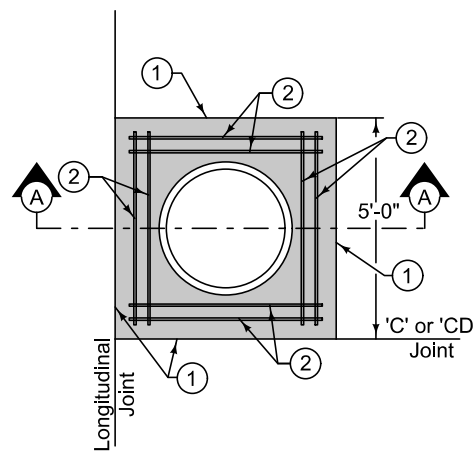

OFFSET AT JOINT INTERSECTION

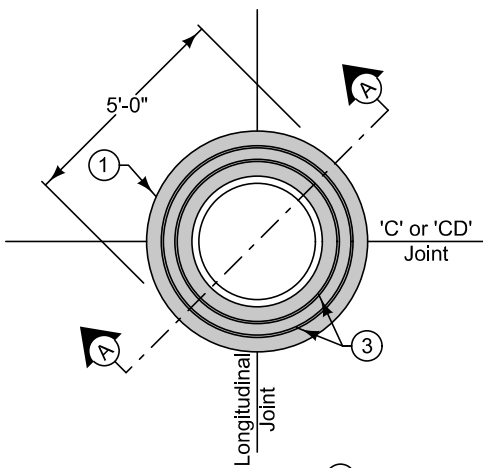

CIRCULAR

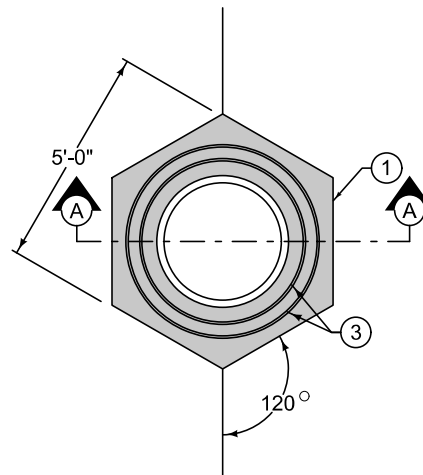

AT A SINGLE JOINT

Construct boxout with Class C concrete or match pavement class. Minimum 2 inches clear on reinforcement. Minimum 12 inches of concrete between outside of casting and nearest joint. Center casting within boxout area if possible.

- ① 'KT-1', 'KT-2', 'BT-1', or 'BT-2' joint if three-piece floating casting (SW 601 Type B and D or SW-602 Type F) is used. 'E' joint if two-piece fixed casting (SW 601 Type A and C or SW-602 Type E) is used.
- ② 4 foot 8 inch (typ.) #4 bar. Place at mid-slab.
- ③ #4 hoops (variable length). Place at mid-slab.
- ④ No boxout is required for three-piece floating castings (SW 601 Type B and D or SW-602 Type F). If a boxout is used with a three-piece casting, construct as detailed in Section A-A for three-piece floating casting.
- ⑤ If a circular boxout is cut and extracted after PCC construction, a 'B' joint may be substituted for the 'E' joint if approved by the Engineer.

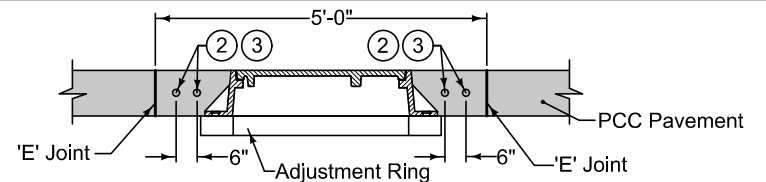

SECTION A-A  
(For two-piece fixed casting)

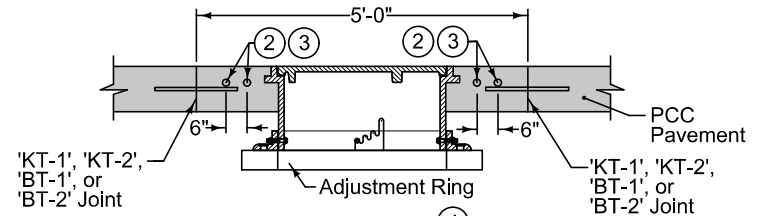

SECTION A-A ④  
(For three-piece floating casting)

	REVISION	
	1	05-23/25
STANDARD ROAD PLAN		BETT7010.103
		SHEET 1 of 1

REVISIONS:	
SUDAS DIRECTOR	DESIGN METHODS ENGINEER

**MANHOLE BOXOUTS IN  
PCC PAVEMENT**

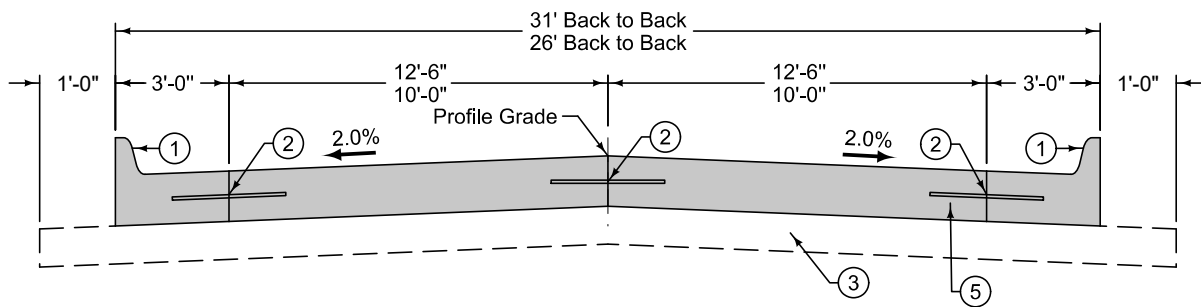
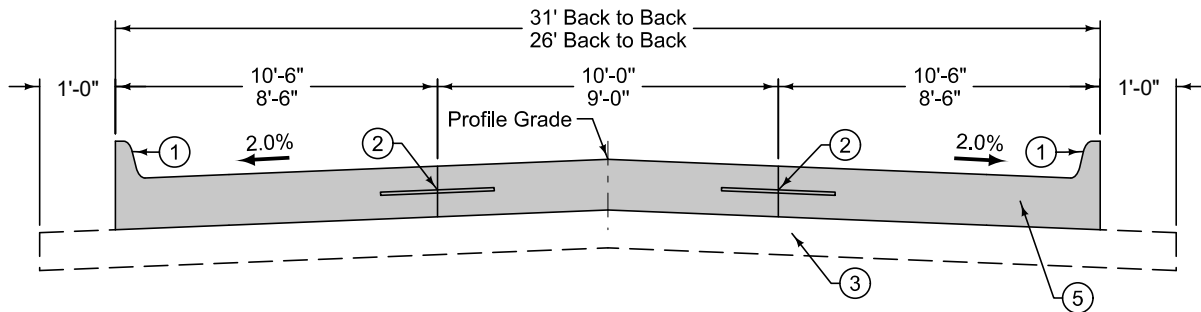
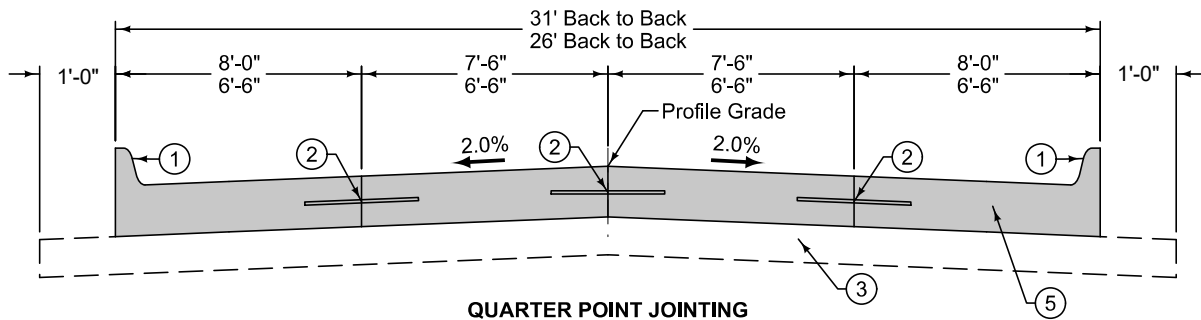

- ① 6 inch standard curb or 4 inch sloped curb.
- ② BT, KT, or L joint depending on pavement thickness and construction staging.
- ③ Subbase or subgrade as specified.
- ④ Unless otherwise specified in the contract documents.
- ⑤ No dowels within 24" of the back of curb. With gutterline joint, place first dowel 6 inches from the joint. See Figure 7010.101, Sheet 8.

TRANSVERSE JOINT REQUIREMENTS ④		
Pavement Thickness	Transverse Joint Type	Transverse Joint Spacing
6"	C	15'
7"	C	15'
8"	CD ⑤	15'
9"	CD ⑤	15'
≥10"	CD ⑤	17'

REVISION	
1	05-23/25
BETT7010.901	
SHEET 1 of 1	

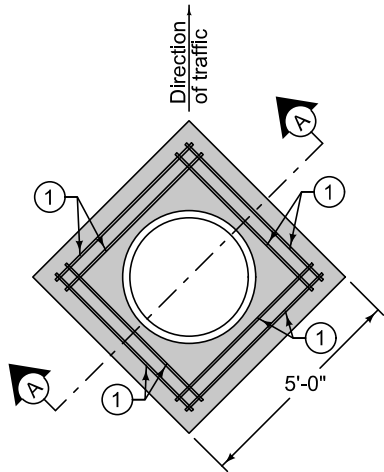

**RECTANGULAR**

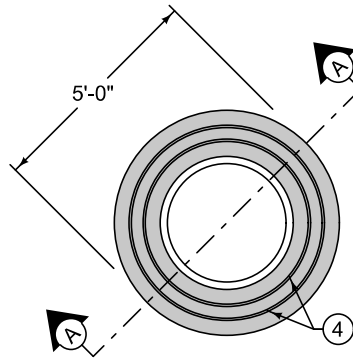

**CIRCULAR**

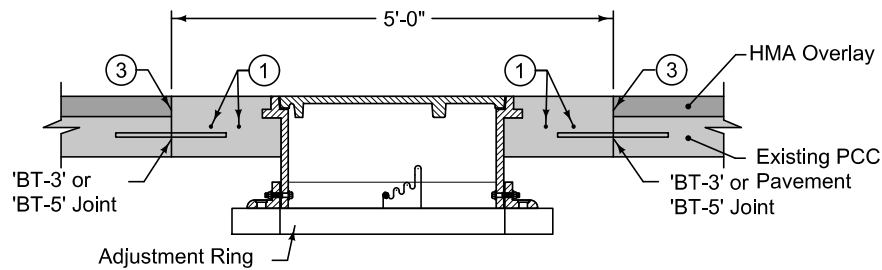

**SECTION A-A**  
(For three-piece floating casting)

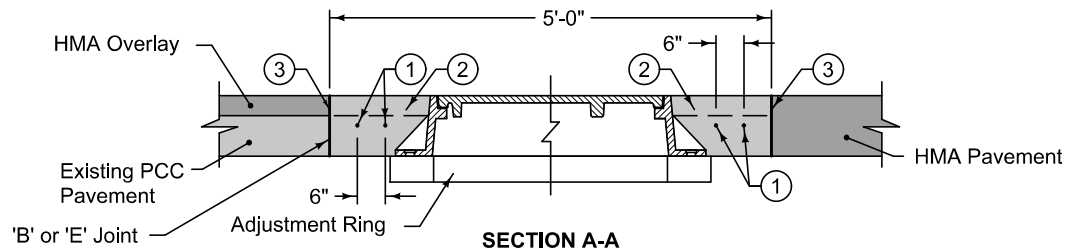

**SECTION A-A**  
(For two-piece fixed casting)

Construct boxout with Class C concrete or match pavement class. Minimum 2 inches clear on reinforcement. Minimum 12 inches of concrete between outside of casting and nearest joint. Center casting within boxout area if possible.

- ① 4 foot 8 inch (typ.) #4 bar. Place at mid-slab.
- ② If boxout is constructed prior to placement of HMA overlay or final lift of HMA pavement, boxout may be constructed low, with a 'B' joint in place of the 'E' joint, and then final lift or overlay placed.
- ③ Apply tack coat.
- ④ #4 hoops (variable length). Place at mid-slab.

NOTE: CONTRACTOR MAY ADD 2" TO DEPTH OF PAVEMENT IN LIEU OF STEEL REINFORCEMENT.

	REVISION
	1 05-23/25
STANDARD ROAD PLAN	BETT7020.201
SHEET 1 of 1	
REVISIONS:	
SUDAS DIRECTOR	DESIGN METHODS ENGINEER
<b>MANHOLE BOXOUTS IN HMA PAVEMENT AND HMA OVERLAYS</b>	

**GUTTERLINE JOINTING**

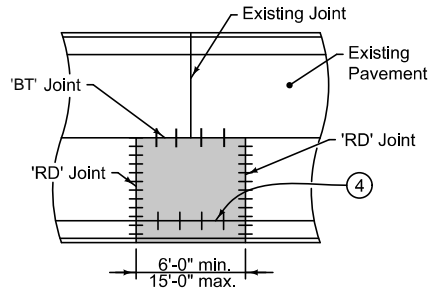

**ONE PANEL WIDTH PATCH WITH OPPOSING JOINT**

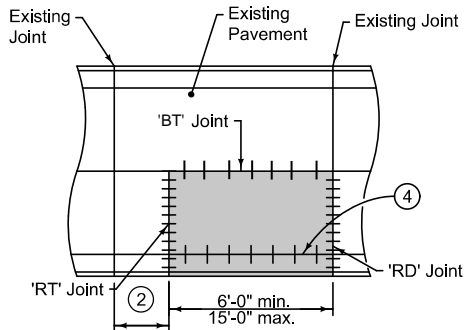

**ONE PANEL WIDTH PATCH NO OPPOSING JOINT**

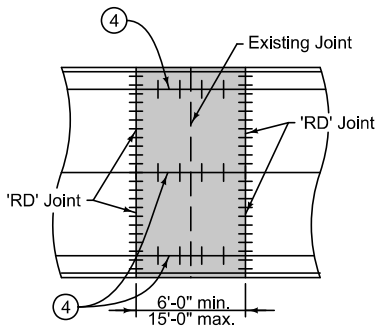

**FULL ROADWAY WIDTH PATCH**

**THIRD POINT JOINTING**

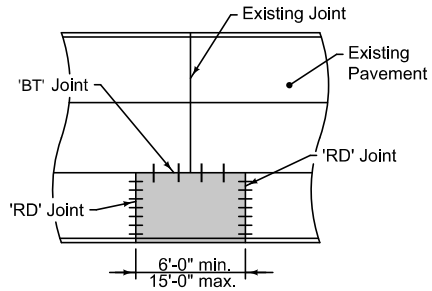

**OUTSIDE PANEL PATCH WITH OPPOSING JOINT**

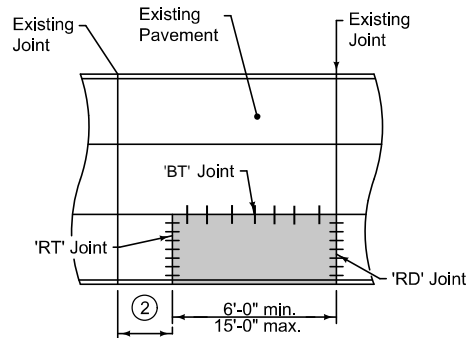

**OUTSIDE PANEL PATCH NO OPPOSING JOINT**

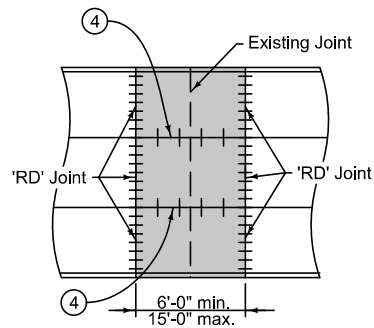

**FULL ROADWAY WIDTH PATCH**

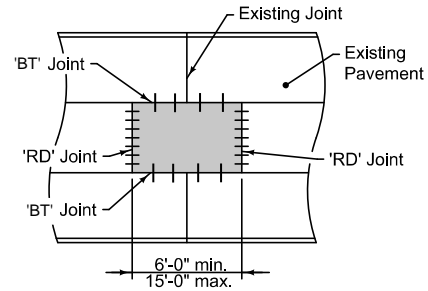

**CENTER PANEL PATCH WITH OPPOSING JOINT**

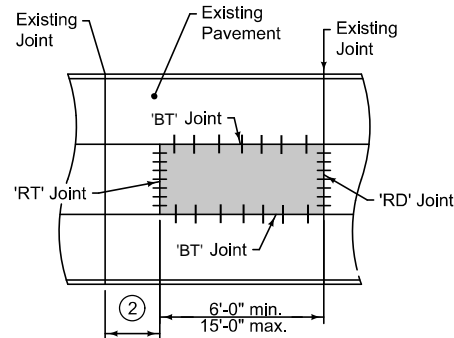

**CENTER PANEL PATCH NO OPPOSING JOINT**

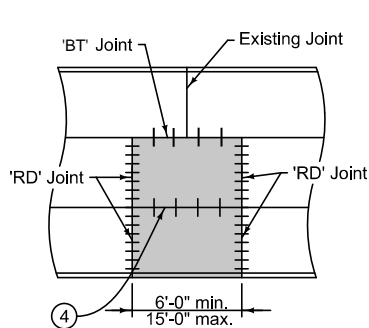

**ADJACENT PANELS PATCH**

- ① Patches on roadways with quarter point jointing will be similar to third point jointing details.
- ② Minimum distance between existing joint and patch is 6 feet. If distance is less than 6 feet, extend patch to existing joint.
- ③ If subgrade or subbase material is required below patch, bring material to a level 2 inches below bottom of existing pavement.
- ④ BT, KT, or L joint depending on pavement thickness and pouring sequence.

**LONGITUDINAL SECTION THRU PCC PATCH**

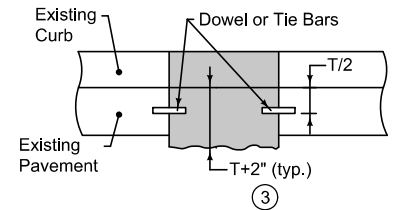

	REVISION	
	1	12-05-25
	BETT7040.101	
SHEET 1 of 1		

**FULL DEPTH PCC PATCHES  
LESS THAN OR EQUAL TO 15' LONG**

Refer to the contract documents for dimensions, grades, and additional requirements for permeable interlocking pavers and associated improvements.

- ① Permeable interlocking pavers as specified in the contract documents.
- ② 2 inch minimum permeable bedding aggregate to accommodate imperfections in the permeable pavement filter aggregate layer.
- ③ Permeable pavement storage aggregate thickness as specified in the contract documents.
- ④ When underdrain collectors and/or laterals are specified, install to the line and grade specified in the contract documents. Place permeable pavement filter aggregate to springline of pipe.
- ⑤ Place 4 inches of filter aggregate under curb and gutter section. Extend to 12 inches beyond the back of curb. Extend engineering fabric under aggregate.
- ⑥ Install paver edge restraint system along unrestrained edges.

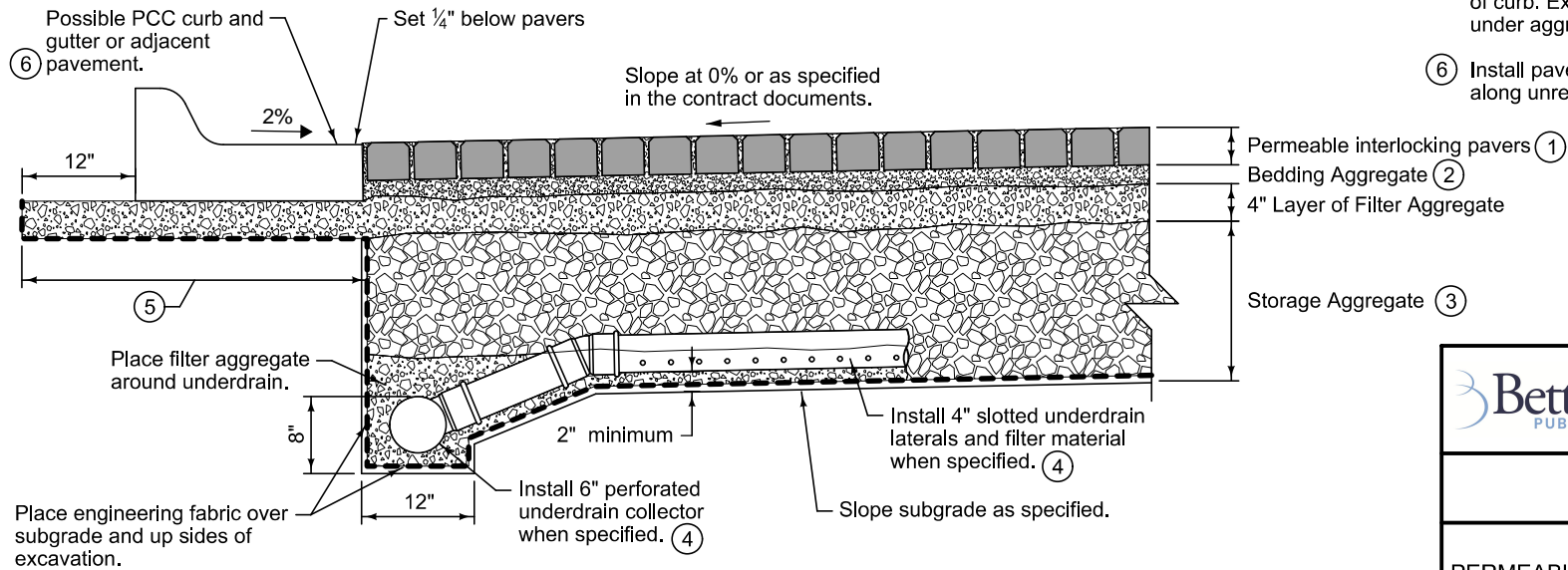

	REVISION	
	1	05-23/25
BETT7080.101		
SHEET 1 of 1		
PERMEABLE INTERLOCKING PAVERS		

**CITY OF BETTENDORF  
COMMITTEE OF THE WHOLE MEETING MINUTES**

**FEBRUARY 17, 2026**

The City Council of Bettendorf, Iowa held their Committee of the Whole on Tuesday, February 17, 2026, at 6:15 p.m., in the Council Chambers at Bettendorf City Hall, 1609 State Street, Bettendorf, Iowa.

The City of Bettendorf broadcasted this public meeting online at [www.bettendorf.org/YouTube](http://www.bettendorf.org/YouTube).

**Council Members Present:** Naumann, Jager, Sechser, Flaherty, Baden, Palczynski

**Council Member Absent:** Brown

**Presiding:** Mayor Robert S. Gallagher

**ITEMS TO APPEAR**

City Engineer Brent Morlok gave an explanation of Items 7 & 8, the public hearing and first reading of an ordinance amending Bettendorf City Code Section 12-3A-3, "Standard Specifications Adopted". Mayor Gallagher asked Council for any questions. Council Members Flaherty, Palczynski, and Jager questioned staff regarding unintended consequences, major changes, and any reduction in our current standards. Mr. Morlok responded accordingly.

**CONSENT AGENDA ITEMS**

Community Development Director Mark Hunt, Senior City Planner Taylor Beswick, and City Attorney Chris Curran gave an explanation of Consent Item E, a resolution approving the final plat of Ann's Nature Preserve Addition, (Case No. 25-042-FP). Mr. Curran addressed the communication received from resident Chad Miller. Mayor Gallagher asked Council for any questions. Council Member Sechser made a motion to move this item to the regular agenda due to Mr. Miller and other neighbors' interest in this matter. Council Member Palczynski seconded the motion. Roll Call vote indicated Flaherty (aye); Sechser (aye); Baden (aye); Palczynski (aye); Naumann (aye); and Jager (aye). The motion passed 6-1 and will be taken up as Item 9 at the regular city council meeting at 7:00 p.m.

Parks and Recreation Director John Byrnes gave an explanation of Consent Item H, a resolution authorizing the Director of Parks and Recreation to sign a Facility Use Agreement between the City of Bettendorf and Bettendorf/Pleasant Valley Youth Baseball (BPV). Mayor Gallagher asked Council for any questions. Council Members Baden, Sechser, Palczynski, Jager, and Flaherty questioned staff regarding reopening the concession stands, maintenance responsibility and costs associated with same, trash removal, affordability of programs, and review of contract after the first year. Mr. Byrnes, Assistant City Administrator Jeff Reiter, and Mayor Gallagher responded accordingly.

Mayor Gallagher asked Council for any questions on the remaining consent agenda items. None presented. Mayor Gallagher asked for a motion to keep all remaining consent agenda items as presented for consideration at tonight's council meeting. Council Member Palczynski made a motion to approve same, and Council Member Naumann seconded the motion. Viva Voce indicated all ayes, and the motion passed 6-1.

**ITEMS ADDED BY MAYOR AND COUNCIL**

No items were added by Mayor and/or Council.

**ADJOURNMENT**

There being no further business, Council Member Sechser made a motion to adjourn, and Council Member Jager seconded the motion. The meeting was adjourned at approximately 6:55 p.m.

\_\_\_\_\_  
Mayor Robert S. Gallagher

Attest:

\_\_\_\_\_  
City Clerk Decker P. Ploehn

**CITY OF BETTENDORF  
CITY COUNCIL MEETING MINUTES**

**FEBRUARY 17, 2026**

The City Council of Bettendorf, Iowa met in regular session on Tuesday, February 17, 2026, at 7:00 p.m., in the Council Chambers at Bettendorf City Hall, 1609 State Street, Bettendorf, Iowa.

The City of Bettendorf broadcasted this public meeting online at [www.bettendorf.org/YouTube](http://www.bettendorf.org/YouTube).

**Council Members Present:** Naumann, Jager, Flaherty, Sechser, Baden, Palczynski

**Council Members Absent:** Brown

**Presiding:** Mayor Robert S. Gallagher

Mayor Gallagher opened the meeting with the Pledge of Allegiance followed by an Invocation given by Bettendorf Police Chaplain and Pastor of Hope Baptist Church, Pastor Mark Cannon.

**PUBLIC REQUESTS OF COUNCIL**

Colin Smith, 1501 State St, addressed the Council with his concerns with Iowa HSB 637 [regarding bicycles, electric personal assistive mobility devices, and pedestrian conveyances] and asked Council to keep their eye on the bill and protect the city's interests with respect to same to keep a bicycle friendly community.

Chad Miller, 4330 Tanglewood Rd, addressed the Council with his concerns on Consent Item E, the final plat of Ann's Nature Preserve Addition, and expressed his support for the recreation trail to the north, and his opposition to any land changes south of the recreation trail including leaving a 1-acre parcel for the potential of a new home to be built by the property owner's nephew. Mr. Miller stated he is concerned that a new home could be three stories tall and have multiple vehicles parked on the lot.

No one else addressed the Council, and the session was closed.

**RECEIPT OF BIDS AND RESOLUTION DIRECTING THE SALE OF \$20,995,000 (SUBJECT TO ADJUSTMENT PER TERMS OF OFFERING) GENERAL OBLIGATION BONDS, SERIES 2026A**

Finance Director Jason Schadt and Elizabeth Bergman, Principal, BakerTilly gave a report of today's bond sale, bids received, and the award of \$20,995,000 (subject to adjustment per terms of offering) General Obligation Bonds, Series 2026A. Mayor Gallagher asked for any questions from Council. None presented. City Administrator Decker Ploehn shared a comment from the S&P rating call that the rating committee recognized the continuity in

stability by both the staff and the council, and they felt the council had a great grasp of what is happening with regard to debt and acting very prudently.

### **RESOLUTION**

Council Member Naumann presented a resolution determining the bid from Piper Sandler & Co., to be the best and most favorable bid received, and the General Obligation Bond Series 2026A be awarded at a final par amount as adjusted in the amount of \$19,745,000 at a true interest rate of 3.2872% and total purchase price adjusted in the amount of \$22,051,268.74, and made a motion to approve the resolution as presented. Council Member Sechser seconded the motion. Mayor Gallagher asked for any discussion from Council. None presented. Roll call vote indicated Flaherty (aye); Sechser (aye); Baden (aye); Palczynski (aye); Naumann (aye); and Jager (aye). The motion passed 6-0.

### **PUBLIC HEARING AND FIRST READING OF AN ORDINANCE AMENDING BETTENDORF CITY CODE SECTION 12-3A-3, "STANDARD SPECIFICATIONS ADOPTED"**

Mayor Gallagher asked council for any questions. None presented. Mayor Gallagher verified that the Notice of Public Hearing had been published and no written correspondence had been received on the matter. Mayor Gallagher then opened the public hearing. No one addressed the Council, and the public hearing was closed.

Council Member Sechser presented the first reading of an ordinance amending Bettendorf City Code Section 12-3A-3, "Standard Specifications Adopted", and made a motion to approve the ordinance at its first reading as presented. Council Member Baden seconded the motion. Mayor Gallagher asked for any discussion from Council. None presented. Roll call vote indicated Flaherty (aye); Sechser (aye); Baden (aye); Palczynski (aye); Naumann (aye); and Jager (aye). The motion passed 6-0.

### **RESOLUTION APPROVING THE FINAL PLAT OF ANN'S NATURE PRESERVE ADDITION (CASE 25-042-FP) (CONSENT E)**

This item was moved to the regular agenda from the consent agenda by Council Member Sechser at the Committee of the Whole meeting at 6:15 p.m. just prior to this meeting. Council Member Palczynski presented a resolution approving the final plat of Ann's Nature Preserve Addition, and made a motion to approve the resolution as presented. Council Member Naumann seconded the motion. Mayor Gallagher asked for any discussion from Council. None presented. Roll call vote indicated Flaherty (aye); Sechser (aye); Baden (aye); Palczynski (aye); Naumann (aye); and Jager (aye). The motion passed 6-0.

### **CONSENT AGENDA**

Mayor Gallagher asked for a motion to approve the Consent Agenda as presented [minus Item E]. Council Member Palczynski made a motion to approve the Consent Agenda as presented, and Council Member Flaherty seconded the motion. Mayor Gallagher asked Council for any questions. None presented. Roll call vote indicated Flaherty (aye); Sechser (aye); Baden (aye); Palczynski (aye); Naumann (aye); and Jager (aye). The motion passed 6-0.

**ADJOURNMENT**

There being no further business, Council Member Naumann made a motion to adjourn, and Council Member Palczynski seconded the motion. The meeting was adjourned at approximately 7:18 p.m.

---

Mayor Robert S. Gallagher

Attest:

---

City Clerk Decker P. Ploehn

**CONSENT AGENDA  
FEBRUARY 17, 2026**

**ALL ITEMS APPEARING BELOW ARE CONSIDERED ROUTINE BY THE CITY COUNCIL  
AND SHALL BE ENACTED BY ONE MOTION. IF DISCUSSION IS DESIRED, THAT ITEM SHALL BE  
REMOVED AND DISCUSSED SEPARATELY**

- A. Minutes from February 3 and 9, 2026. (Approve and Adopt)
- B. Resolution receiving and filing the December Monthly Finance Summary. (Approve and Adopt)
- C. Resolution awarding the contract and approving the contract and bond for the 29<sup>th</sup> Street Reconstruction Project from Middle Road to Maplecrest Road. (Approve and Adopt)
- D. Resolution setting the date for a public hearing and directing the advertising for bids for the Public Works Fire Suppression System Project. (Approve and Adopt)
- E. ***MOVED TO ITEMS TO APPEAR #9 AT REQUEST OF COUNCIL MEMBER SECHSER AT COMMITTEE OF THE WHOLE MEETING 2/17/26 HELD JUST PRIOR TO REGULAR CITY COUNCIL MEETING***
- F. Resolution approving updates to the City of Bettendorf's Substance Abuse Policy. (Approve and Adopt)
- G. Resolution approving the health plan proposal from Wellmark for health insurance service, prescription coverage, and stop loss protection, Delta Dental for dental coverage, and Employee Benefit Systems for vision coverage effective March 2, 2026 through February 28, 2027, and authorizing the Mayor and City Administrator to execute contracts for same. (Approve and Adopt)
- H. Resolution authorizing the Parks and Recreation Director to sign a facility use agreement between the City of Bettendorf and the Bettendorf/Pleasant Valley Youth Baseball (BPV). (Approve and Adopt)
- I. Resolution approving alcohol license renewals and requests for Adventurous Brewing, Malibu Jacks, QC Mart (Central Ave), Oscar's Pub, Palmer Hills Grill, and an ownership update for all QC Mart locations (Central Ave, Grant St, & 18th St). (Approve and Adopt)
- J. Bills (Approve payment and direct City Clerk to issue checks in respective amounts)

**CITY OF BETTENDORF  
COMMITTEE OF THE WHOLE WORK SESSION MINUTES**

**FEBRUARY 23, 2026**

The City Council of Bettendorf, Iowa held a Committee of the Whole Work Session on Monday, February 23, 2026, at 3:30 p.m., in the Council Chambers at Bettendorf City Hall, 1609 State Street, Bettendorf, Iowa.

The City of Bettendorf did not broadcast this public meeting online.

**Council Members Present:** Naumann, Brown, Flaherty, Sechser, Baden, Palczynski

**Council Members Absent:** Jager

**Presiding:** Mayor Robert S. Gallagher

**Staff and Developers Present:** Parks and Recreation Director John Brynes, City Administrator Decker Ploehn, Assistant City Administrator Jeff Reiter, City Attorney Chris Curran, Community Development Director Mark Hunt, Family Museum Director Kim Kidwell, Public Works Director Brian Schmidt, Jennifer Radloff, Managing Director, Shive-Hattery, Holly Reid, Landscape Architect, Shive-Hattery, and Matthew Avila, Hunden Partners

Matthew Avila, Hunden Partners, presented the market analysis for the proposed Forest Grove Park, including a SWOT assessment, preliminary survey findings, and a review of regional parks.

Discussion followed on Mr. Avila's presentation, including discussion of proposed characteristics of the future park, as well as operational and maintenance cost, and revenue generation. Parks and Recreation Director John Brynes summarized the discussion, and the timeline for next steps was reviewed. No action was taken.

The session concluded at approximately 5:15 p.m.

---

Mayor Robert S. Gallagher

Attest:

---

City Clerk Decker P. Ploehn

## COUNCIL LETTER

**MEETING DATE:** March 3, 2026  
**REQUESTED BY:** Jason Schadt, Finance Director

---

### Item Title

\$19,745,000 General Obligation Bonds, Series 2026A

- Resolution Appointing Paying Agent, Bond Registrar, and Transfer Agent, Approving the Paying Agent and Bond Registrar and Transfer Agent Agreement and Authorizing the Execution of the Agreement.
- Resolution authorizing and providing for the issuance, and levying a tax to pay the Bonds; Approval of the Tax Exemption Certificate and Continuing Disclosure Certificate.

### Explanation

**\$19,745,000 General Obligation Bonds, Series 2026A**

The public sale of \$19,745,000 General Obligation Bonds, Series 2026A took place February 17, 2026 at 10:00 A.M. with award by the City Council at 7:00 p.m. that same day. The awarded bidder was Piper Sandler & Co., at a final true interest cost of 3.2872%. The attached resolutions prepared by our bond counsel Ahlers & Cooney, P.C. authorize the issuance of said bonds, approve the continuing disclosure certificate, as well as UMB Bank N.A. of West Des Moines as the registrar and paying agent, and authorize the execution of the agreement.

Net proceeds from these bonds will pay for various public improvement projects as listed in the City's FY 2026/27 budget document and project summary list, including the voter approved police station. The City's Debt Service levy will increase about \$0.21 per \$1,000 assessed valuation for the first portion of the voter approved bonds.

Public hearings were held at the regular City Council meeting on January 20, 2026. S&P Global Ratings assigned their AA+ rating the issue.

### **If the matter is not budgeted in the current year, explain why funding is requested and the anticipated source:**

The proposed General Obligation bond issues, as structured by Baker Tilly Municipal Advisors, are covered by the City's Debt Service levy as adopted in the FY 25/26 budget. The first principal and interest payments due on these bonds have been properly included in the FY 26/27 budget. A larger portion of future debt service payments on the Urban Renewal bonds will be offset by tax increment revenue.

### List Attachments

- Resolutions prepared by Ahlers & Cooney, P.C. for General Obligation Bonds, Series 2026A
- Tax Exempt Certificate, Registrar's Agreement, Authentication Order, County Auditor's Certificate, Delivery Certificate, Transcript Certificate, and Continuing Disclosure Certificate

**ITEMS TO INCLUDE ON AGENDA**

**CITY OF BETTENDORF, IOWA**

\$19,745,000 General Obligation Bonds, Series 2026A

- Resolution Appointing Paying Agent, Bond Registrar, and Transfer Agent, Approving the Paying Agent and Bond Registrar and Transfer Agent Agreement and Authorizing the Execution of the Agreement.
- Resolution authorizing and providing for the issuance, and levying a tax to pay the Bonds; Approval of the Tax Exemption Certificate and Continuing Disclosure Certificate.

NOTICE MUST BE GIVEN PURSUANT TO IOWA CODE  
CHAPTER 21 AND THE LOCAL RULES OF THE CITY.

March 3, 2026

The City Council of the City of Bettendorf, State of Iowa, met in \_\_\_\_\_ session, in the Council Chambers, City Hall, 1609 State Street, Bettendorf, Iowa, at \_\_\_\_\_ .M., on the above date. There were present Mayor \_\_\_\_\_, in the chair, and the following named Council Members:

\_\_\_\_\_

Absent: \_\_\_\_\_

Vacant: \_\_\_\_\_

\* \* \* \* \*

Council Member \_\_\_\_\_ introduced the following resolution entitled "RESOLUTION APPOINTING UMB BANK, N.A. OF WEST DES MOINES, IOWA, TO SERVE AS PAYING AGENT, BOND REGISTRAR, AND TRANSFER AGENT, APPROVING THE PAYING AGENT AND BOND REGISTRAR AND TRANSFER AGENT AGREEMENT AND AUTHORIZING THE EXECUTION OF THE AGREEMENT", and moved that the resolution be adopted. Council Member \_\_\_\_\_ seconded the motion to adopt. The roll was called and the vote was,

AYES: \_\_\_\_\_

\_\_\_\_\_

NAYS: \_\_\_\_\_

Whereupon, the Mayor declared said Resolution duly adopted as follows:

RESOLUTION APPOINTING UMB BANK, N.A. OF WEST DES MOINES, IOWA, TO SERVE AS PAYING AGENT, BOND REGISTRAR, AND TRANSFER AGENT, APPROVING THE PAYING AGENT AND BOND REGISTRAR AND TRANSFER AGENT AGREEMENT AND AUTHORIZING THE EXECUTION OF THE AGREEMENT

WHEREAS, \$19,745,000 General Obligation Bonds, Series 2026A, dated March 26, 2026, have been sold and action should now be taken to provide for the maintenance of records, registration of certificates and payment of principal and interest in connection with the issuance of the Bonds; and

WHEREAS, this Council has deemed that the services offered by UMB Bank, N.A. of West Des Moines, Iowa, are necessary for compliance with rules, regulations, and requirements governing the registration, transfer and payment of registered bonds; and

WHEREAS, a Paying Agent, Bond Registrar and Transfer Agent Agreement (hereafter "Agreement") has been prepared to be entered into between the City and UMB Bank, N.A.

NOW, THEREFORE, BE IT RESOLVED BY THE CITY COUNCIL OF THE CITY OF BETTENDORF, STATE OF IOWA:

1. That UMB Bank, N.A. of West Des Moines, Iowa, is hereby appointed to serve as Paying Agent, Bond Registrar and Transfer Agent in connection with the issuance of \$19,745,000 General Obligation Bonds, Series 2026A, dated March 26, 2026.

2. That the Agreement with UMB Bank, N.A. of West Des Moines, Iowa, is hereby approved and that the Mayor and Clerk are authorized to sign the Agreement on behalf of the City.

PASSED AND APPROVED this 3<sup>rd</sup> day of March, 2026.

---

Mayor

ATTEST:

---

City Clerk

Council Member \_\_\_\_\_ introduced the following Resolution entitled "RESOLUTION AUTHORIZING AND PROVIDING FOR THE ISSUANCE OF \$19,745,000 GENERAL OBLIGATION BONDS, SERIES 2026A, AND LEVYING A TAX TO PAY SAID BONDS; APPROVAL OF THE TAX EXEMPTION CERTIFICATE AND CONTINUING DISCLOSURE CERTIFICATE" and moved that it be adopted. Council Member \_\_\_\_\_ seconded the motion to adopt, and the roll being called thereon, the vote was as follows:

AYES: \_\_\_\_\_

\_\_\_\_\_

NAYS: \_\_\_\_\_

Whereupon, the Mayor declared said Resolution duly adopted as follows:

RESOLUTION AUTHORIZING AND PROVIDING FOR THE  
ISSUANCE OF \$19,745,000 GENERAL OBLIGATION BONDS,  
SERIES 2026A, AND LEVYING A TAX TO PAY SAID  
BONDS; APPROVAL OF THE TAX EXEMPTION  
CERTIFICATE AND CONTINUING DISCLOSURE  
CERTIFICATE

WHEREAS, the Issuer is duly incorporated, organized and exists under and by virtue of the laws and Constitution of the State of Iowa; and

WHEREAS, the Issuer is in need of funds to pay costs of construction, reconstruction and repair of streets, including resurfacing and paving improvements, grade crossing separations and approaches, including related to railroad crossing improvements; sidewalks, pedestrian underpasses and overpasses, alleys, public ground and trail right of way; acquisition and installation of traffic control devices; acquisition, construction, improvement and installation of street lighting fixtures, connections and facilities; and construction, reconstruction, enlargement, improvement and repair of bridges, essential corporate purpose(s), and it is deemed necessary and advisable that General Obligation Bonds, to the amount of not to exceed \$9,500,000 be authorized for said purpose(s); and

WHEREAS, pursuant to notice published as required by Section 384.25 of the Code of Iowa, this Council has held a public meeting and hearing upon the proposal to institute proceedings for the issuance of the Bonds, and the Council is therefore now authorized to proceed with the issuance of said Bonds for such purpose(s); and

WHEREAS, the Issuer is in need of funds to pay costs of aiding in the planning, undertaking and carrying out of urban renewal projects under the authority of Iowa Code chapter

403 and the Urban Renewal Plan for the I-80 Urban Renewal Area, as amended, including the Middle Road Public Pedestrian Bridge and Trails project, essential corporate urban renewal purpose project(s), and it is deemed necessary and advisable that the City issue General Obligation Urban Renewal Bonds, for such purpose(s) to the amount of not to exceed \$2,945,000 as authorized by Sections 384.25 and 403.12 of the Code of Iowa; and

WHEREAS, pursuant to notice published as required by Sections 384.25 and 403.12 this Council has held a public meeting and hearing upon the proposal to institute proceedings for the issuance of not to exceed \$11,000,000 General Obligation Urban Renewal Bonds, and all objections, if any, to such Council action made by any resident or property owner of the City were received and considered by the Council; and no petition having been filed, it is the decision of the Council that additional action be taken for the issuance of said Bonds for such purpose(s), and that such action is considered to be in the best interests of the City and the residents thereof; and

WHEREAS, the Issuer created authority to issue up to \$11,000,000 of General Obligation Urban Renewal Bonds for the issuance of said purposes, and to date has issued Bonds thereunder in an amount of \$2,400,000 (Series 2024) and \$5,655,000 (Series 2025A), therefore the Council is now authorized to proceed with the issuance of remaining \$2,945,000 of said authority, as contemplated herein; and

WHEREAS, the Issuer is in need of funds to pay costs of constructing, equipping and furnishing a police station and related site improvements, general corporate purpose(s), and it is deemed necessary and advisable that General Obligation Bonds, to the amount of \$9,160,000 be authorized for said purpose(s), the first issuance of authority created by election; and

WHEREAS, this Council, pursuant to Section 384.26 of the Code of Iowa, did legally call a City election, fixing the time and place thereof, and did legally submit to the qualified electors of the City the proposition of issuing General Obligation Bonds of the City in an amount of not to exceed \$27,000,000, for the aforesaid purpose(s), and caused to be given legal, sufficient and timely notice of said election and the time, place and purpose thereof; and

WHEREAS, the City election was duly and legally held and conducted on November 4, 2025, pursuant to a legal notice duly given by publication in a legal newspaper, printed wholly in the English language, published at least once weekly, and having general circulation in the City, said publication in said newspaper appearing on a date not less than ten (10) clear days nor more than twenty (20) days prior to the date of said election, all in strict compliance with the law and the orders of said Council and the County Commissioner of Elections. The affirmative vote on the proposition was equal to more than 60% of the total vote cast for and against the proposition at said election. The proposition was declared and certified to have been duly adopted, no contest thereof having been made, and the Issuer desires to proceed with the issuance of said Bonds for such purpose(s) so authorized at the election, and

WHEREAS, pursuant to Section 384.28 of the Code of Iowa, it is hereby found and determined that the various general obligation Bonds authorized as hereinabove described shall be combined for the purpose of issuance in a single issue of \$19,745,000 General Obligation Bonds as hereinafter set forth; and

WHEREAS, pursuant to the provisions of Chapter 75 of the Code of Iowa, the above mentioned Bonds were heretofore sold at public sale and action should now be taken to issue said Bonds conforming to the terms and conditions of the best bid received at the advertised public sale.

NOW, THEREFORE, BE IT RESOLVED BY THE CITY COUNCIL OF THE CITY OF BETTENDORF, STATE OF IOWA:

Section 1. Definitions. The following terms shall have the following meanings in this Resolution unless the text expressly or by necessary implication requires otherwise:

- "Authorized Denominations" shall mean \$5,000 or any integral multiple thereof.
- "Beneficial Owner" shall mean, whenever used with respect to a Bond, the person in whose name such Bond is recorded as the beneficial owner of such Bond by a Participant on the records of such Participant or such person's subrogee.
- "Blanket Issuer Letter of Representations" shall mean the Representation Letter from the Issuer to DTC, with respect to the Bonds.
- "Bond Fund" shall mean the fund created in Section 3 of this Resolution.
- "Bonds" shall mean \$19,745,000 General Obligation Bonds, Series 2026A, authorized to be issued by this Resolution.
- "Cede & Co." shall mean Cede & Co., the nominee of DTC, and any successor nominee of DTC with respect to the Bonds.
- "Continuing Disclosure Certificate" shall mean that certain Continuing Disclosure Certificate approved under the terms of this Resolution and to be executed by the Issuer and dated the date of issuance and delivery of the Bonds, as originally executed and as it may be amended from time to time in accordance with the terms thereof.
- "Depository Bonds" shall mean the Bonds as issued in the form of one global certificate for each maturity, registered in the Registration Books maintained by the Registrar in the name of DTC or its nominee.
- "DTC" shall mean The Depository Trust Company, New York, New York, which will act as security depository for the Bond pursuant to the Representation Letter.
- "Issuer" and "City" shall mean the City of Bettendorf, State of Iowa.
- "Participants" shall mean those broker-dealers, banks and other financial institutions for which DTC holds Bonds as securities depository.

- "Paying Agent" shall mean UMB Bank, N.A., or such successor as may be approved by Issuer as provided herein and who shall carry out the duties prescribed herein as Issuer's agent to provide for the payment of principal of and interest on the Bonds as the same shall become due.

- "Project" shall mean the costs of construction, reconstruction and repair of streets, including resurfacing and paving improvements, grade crossing separations and approaches, including related to railroad crossing improvements; sidewalks, pedestrian underpasses and overpasses, alleys, public ground and trail right of way; acquisition and installation of traffic control devices; acquisition, construction, improvement and installation of street lighting fixtures, connections and facilities; and construction, reconstruction, enlargement, improvement and repair of bridges; aiding in the planning, undertaking and carrying out of urban renewal projects under the authority of Iowa Code chapter 403 and the Urban Renewal Plan for the I-80 Urban Renewal Area, as amended, including the Middle Road Public Pedestrian Bridge and Trails project; and constructing, equipping and furnishing a police station and related site improvements.

- "Project Fund" shall mean the fund required to be established by this Resolution for the deposit of the proceeds of the Bonds.

- "Rebate Fund" shall mean the fund so defined in and established pursuant to the Tax Exemption Certificate.

- "Registrar" shall mean UMB Bank, N.A. of West Des Moines, Iowa, or such successor as may be approved by Issuer as provided herein and who shall carry out the duties prescribed herein with respect to maintaining a register of the owners of the Bonds. Unless otherwise specified, the Registrar shall also act as Transfer Agent for the Bonds.

- "Resolution" shall mean this resolution authorizing the Bonds.

- "Tax Exemption Certificate" shall mean the Tax Exemption Certificate approved under the terms of this Resolution and to be executed by the Treasurer and delivered at the time of issuance and delivery of the Bonds.

- "Treasurer" shall mean the Finance Director or such other officer as shall succeed to the same duties and responsibilities with respect to the recording and payment of the Bonds issued hereunder.

Section 2. Levy and Certification of Annual Tax; Other Funds to be Used.

a) Levy of Annual Tax. That for the purpose of providing funds to pay the principal and interest of the Bonds hereinafter authorized to be issued, there is hereby levied for each future year the following direct annual tax on all of the taxable property in the City of Bettendorf, State of Iowa, to-wit:

AMOUNT	FISCAL YEAR (JULY 1 TO JUNE 30) YEAR OF COLLECTION
\$1,755,684.03	2026/2027
\$1,753,050.00	2027/2028
\$1,751,050.00	2028/2029
\$1,757,050.00	2029/2030
\$1,755,550.00	2030/2031
\$1,756,800.00	2031/2032
\$1,755,550.00	2032/2033
\$1,751,800.00	2033/2034
\$1,750,550.00	2034/2035
\$1,751,550.00	2035/2036
\$1,749,550.00	2036/2037
\$1,754,550.00	2037/2038
\$1,751,050.00	2038/2039
\$1,754,300.00	2039/2040
\$ 948,800.00	2040/2041
\$ 947,600.00	2041/2042
\$ 945,200.00	2042/2043
\$ 951,600.00	2043/2044
\$ 946,400.00	2044/2045

(NOTE: For example the levy to be made and certified against the taxable valuations of January 1, 2025 will be collected during the fiscal year commencing July 1, 2026.)

b) Resolution to be Filed With County Auditor. A certified copy of this Resolution shall be filed with the Auditor of Scott County, Iowa and the Auditor is hereby instructed in and for each of the years as provided, to levy and assess the tax hereby authorized in Section 2 of this Resolution, in like manner as other taxes are levied and assessed, and such taxes so levied in and for each of the years aforesaid be collected in like manner as other taxes of the City are collected, and when collected be used for the purpose of paying principal and interest on said Bonds issued in anticipation of the tax, and for no other purpose whatsoever.

c) Additional City Funds Available. Principal and interest coming due at any time when the proceeds of said tax on hand shall be insufficient to pay the same shall be promptly paid when due from current funds of the City available for that purpose and reimbursement shall be made from such special fund in the amounts thus advanced.

Section 3. Bond Fund. Said tax shall be assessed and collected each year at the same time and in the same manner as, and in addition to, all other taxes in and for the City, and when collected they shall be converted into a special fund within the Debt Service Fund to be known as the "2026 GENERAL OBLIGATION BOND FUND NO. 1" (the "Bond Fund"), which is hereby pledged for and shall be used only for the payment of the principal of and interest on the Bonds hereinafter authorized to be issued; and also there shall be apportioned to said fund its

proportion of taxes received by the City from property that is centrally assessed by the State of Iowa.

Section 4. Application of Bond Proceeds. Proceeds of the Bonds, other than accrued interest except as may be provided below, shall be credited to the Project Fund and expended therefrom for the purposes of issuance. Any amounts on hand in the Project Fund shall be available for the payment of the principal of or interest on the Bonds at any time that other funds shall be insufficient to the purpose, in which event such funds shall be repaid to the Project Fund at the earliest opportunity. Any balance on hand in the Project Fund and not immediately required for its purposes may be invested not inconsistent with limitations provided by law or this Resolution.

Section 5. Investment of Bond Fund Proceeds. All moneys held in the Bond Fund, provided for by Section 3 of this Resolution shall be invested in investments permitted by Chapter 12B, Code of Iowa, as amended, or deposited in financial institutions which are members of the Federal Deposit Insurance Corporation and the deposits in which are insured thereby and all such deposits exceeding the maximum amount insured from time to time by FDIC or its equivalent successor in any one financial institution shall be continuously secured in compliance with Chapter 12C of the Code of Iowa, as amended, or otherwise by a valid pledge of direct obligations of the United States Government having an equivalent market value. All such interim investments shall mature before the date on which the moneys are required for payment of principal of or interest on the Bonds as herein provided.

Section 6. Bond Details, Execution and Redemption.

a) Bond Details. General Obligation Bonds of the City in the amount of \$19,745,000, shall be issued pursuant to the provisions of Sections 384.25, 384.26, 384.28 and 403.12 of the Code of Iowa for the aforesaid purposes. The Bonds shall be designated "GENERAL OBLIGATION BOND, SERIES 2026A", be dated March 26, 2026, and bear interest from the date thereof, until payment thereof, at the office of the Paying Agent, said interest payable on December 1, 2026, and semiannually thereafter on the 1st day of June and December in each year until maturity at the rates hereinafter provided.

The Bonds shall be executed by the manual or facsimile signature of the Mayor and attested by the manual or facsimile signature of the Clerk, and impressed or printed with the seal of the City and shall be fully registered as to both principal and interest as provided in this Resolution; principal, interest and premium, if any, shall be payable at the office of the Paying Agent by mailing of a check to the registered owner of the Bond. The Bonds shall be in the denomination of \$5,000 or multiples thereof. The Bonds shall mature and bear interest as follows:

Principal Amount	Interest Rate	Maturity June 1 <sup>st</sup>
\$ 640,000	5.000%	2027
\$ 840,000	5.000%	2028
\$ 880,000	5.000%	2029
\$ 930,000	5.000%	2030
\$ 975,000	5.000%	2031
\$1,025,000	5.000%	2032
\$1,075,000	5.000%	2033
\$1,125,000	5.000%	2034
\$1,180,000	5.000%	2035
\$1,240,000	5.000%	2036
\$1,300,000	5.000%	2037
\$1,370,000	5.000%	2038
\$1,435,000	5.000%	2039
\$1,510,000	5.000%	2040
\$ 780,000	4.000%	2041
\$ 810,000	4.000%	2042
\$2,630,000	4.000%	2045*

\*Term Bonds

b) Redemption.

i. Optional Redemption. Bonds maturing after June 1, 2035, may be called for optional redemption by the Issuer on that date or any date thereafter, from any funds regardless of source, in whole or from time to time in part, in any order of maturity and within an annual maturity by lot. The terms of redemption shall be par, plus accrued interest to date of call.

Thirty days' written notice of redemption shall be given to the registered owner of the Bond. Failure to give written notice to any registered owner of the Bonds or any defect therein shall not affect the validity of any proceedings for the redemption of the Bonds. All Bonds or portions thereof called for redemption will cease to bear interest after the specified redemption date, provided funds for their redemption are on deposit at the place of payment. Written notice will be deemed completed upon transmission to the owner of record.

If selection by lot within a maturity is required, the Registrar shall designate the Bonds to be redeemed by random selection of the names of the registered owners of the entire annual maturity until the total amount of Bonds to be called has been reached.

If less than all of a maturity is called for redemption, the Issuer will notify DTC of the particular amount of such maturity to be redeemed prior to maturity. DTC will determine by lot the amount of each Participant's interest in such

maturity to be redeemed and each Participant will then select by lot the beneficial ownership interests in such maturity to be redeemed. All prepayments shall be at a price of par plus accrued interest.

ii. Mandatory Payment and Redemption of Term Bonds. All Term Bonds are subject to mandatory redemption prior to maturity at a price equal to 100% of the portion of the principal amount thereof to be redeemed plus accrued interest at the redemption date on June 1st of each of the years in the principal amount set opposite each year in the following schedule:

Term Bond #1		
Principal Amount	Interest Rate	Maturity June 1 <sup>st</sup>
\$840,000	4.000%	2043
\$880,000	4.000%	2044
\$910,000	4.000%	2045*

\*Final Maturity

The principal amount of Term Bonds may be reduced through the earlier optional redemption, with any partial optional redemption of the Term Bonds credited against future mandatory redemption requirements for such Term Bonds in such order as the City shall determine.

c) Urban Renewal Purposes.

The Bonds are hereby declared to be issued for essential public and governmental purposes for qualified urban renewal projects.

The Bonds shall recite in substance that they have been issued by the City in connection with an urban renewal project as defined by Chapter 403 of the Code of Iowa, and in any suit, action or proceeding involving the validity or enforceability of any bond issued hereunder or the security therefor, such Bond shall be conclusively deemed to have been issued for such purpose and such project shall be conclusively deemed to have been planned, located and carried out in accordance with the provisions of Chapter 403 of the Code of Iowa.

Section 7. Issuance of Bonds in Book-Entry Form; Replacement Bonds.

a) Notwithstanding the other provisions of this Resolution regarding registration, ownership, transfer, payment and exchange of the Bonds, unless the Issuer determines to permit the exchange of Depository Bonds for Bonds in Authorized Denominations, the Bonds shall be issued as Depository Bonds in denominations of the entire principal amount of each maturity of Bonds (or, if a portion of said principal amount is prepaid, said principal amount less the prepaid amount). The Bonds must be registered in the

name of Cede & Co., as nominee for DTC. Payment of semiannual interest for any Bonds registered in the name of Cede & Co. will be made by wire transfer or New York Clearing House or equivalent next day funds to the account of Cede & Co. on the interest payment date for the Bonds at the address indicated or in the Representation Letter.

b) The Bonds will be initially issued in the form of separate single authenticated fully registered bonds in the amount of each stated maturity of the Bonds. Upon initial issuance, the ownership of the Bonds will be registered in the registry books of the UMB Bank, N.A. kept by the Paying Agent and Registrar in the name of Cede & Co., as nominee of DTC. The Paying Agent and Registrar and the Issuer may treat DTC (or its nominee) as the sole and exclusive owner of the Bonds registered in its name for the purposes of payment of the principal or redemption price of or interest on the Bonds, selecting the Bonds or portions to be redeemed, giving any notice permitted or required to be given to registered owners of Bonds under the Resolution of the Issuer, registering the transfer of Bonds, obtaining any consent or other action to be taken by registered owners of the Bonds and for other purposes. The Paying Agent, Registrar and the Issuer have no responsibility or obligation to any Participant or Beneficial Owner of the Bonds under or through DTC with respect to the accuracy of records maintained by DTC or any Participant; with respect to the payment by DTC or Participant of an amount of principal or redemption price of or interest on the Bonds; with respect to any notice given to owners of Bonds under the Resolution; with respect to the Participant(s) selected to receive payment in the event of a partial redemption of the Bonds, or a consent given or other action taken by DTC as registered owner of the Bonds. The Paying Agent and Registrar shall pay all principal of and premium, if any, and interest on the Bonds only to Cede & Co. in accordance with the Representation Letter, and all payments are valid and effective to fully satisfy and discharge the Issuer's obligations with respect to the principal of and premium, if any, and interest on the Bonds to the extent of the sum paid. DTC must receive an authenticated Bond for each separate stated maturity evidencing the obligation of the Issuer to make payments of principal of and premium, if any, and interest. Upon delivery by DTC to the Paying Agent and Registrar of written notice that DTC has determined to substitute a new nominee in place of Cede & Co., the Bonds will be transferable to the new nominee in accordance with this Section.

c) In the event the Issuer determines that it is in the best interest of the Beneficial Owners that they be able to obtain Bonds certificates, the Issuer may notify DTC and the Paying Agent and Registrar, whereupon DTC will notify the Participants, of the availability through DTC of Bonds certificates. The Bonds will be transferable in accordance with this Section. DTC may determine to discontinue providing its services with respect to the Bonds at any time by giving notice to the Issuer and the Paying Agent and Registrar and discharging its responsibilities under applicable law. In this event, the Bonds will be transferable in accordance with this Section.

d) Notwithstanding any other provision of the Resolution to the contrary, so long as any Bond is registered in the name of Cede & Co., as nominee of DTC, all payments with respect to the principal of and premium, if any, and interest on the Bond and all notices must be made and given, respectively to DTC as provided in the Representation letter.

e) In connection with any notice or other communication to be provided to Bondholders by the Issuer or the Paying Agent and Registrar with respect to a consent or other action to be taken by Bondholders, the Issuer or the Paying Agent and Registrar, as the case may be, shall establish a record date for the consent or other action and give DTC notice of the record date not less than 15 calendar days in advance of the record date to the extent possible. Notice to DTC must be given only when DTC is the sole Bondholder.

f) The Representation Letter is on file with DTC and sets forth certain matters with respect to, among other things, notices, consents and approvals by Bondholders and payments on the Bonds. The execution and delivery of the Representation Letter to DTC by the Issuer is ratified and confirmed.

g) In the event that a transfer or exchange of the Bonds is permitted under this Section, the transfer or exchange may be accomplished upon receipt by the Registrar from the registered owners of the Bonds to be transferred or exchanged and appropriate instruments of transfer. In the event Bond certificates are issued to holders other than Cede & Co., its successor as nominee for DTC as holder of all the Bonds, or other securities depository as holder of all the Bonds, the provisions of the Resolution apply to, among other things, the printing of certificates and the method or payment of principal of and interest on the certificates. Any substitute depository shall be designated in writing by the Issuer to the Paying Agent. Any such substitute depository shall be a qualified and registered "clearing agency" as provided in Section 17A of the Securities Exchange Act of 1934, as amended. The substitute depository shall provide for (i) immobilization of the Depository Bonds, (ii) registration and transfer of interests in Depository Bonds by book entries made on records of the depository or its nominee and (iii) payment of principal of, premium, if any, and interest on the Bonds in accordance with and as such interests may appear with respect to such book entries.

h) The officers of the Issuer are authorized and directed to prepare and furnish to the purchaser, and to the attorneys approving the legality of Bonds, certified copies of proceedings, ordinances, resolutions and records and all certificates and affidavits and other instruments as may be required to evidence the legality and marketability of the Bonds, and all certified copies, certificates, affidavits and other instruments constitute representations of the Issuer as to the correctness of all stated or recited facts.

Section 8. Registration of Bonds; Appointment of Registrar; Transfer; Ownership; Delivery; and Cancellation.

a) Registration. The ownership of Bonds may be transferred only by the making of an entry upon the books kept for the registration and transfer of ownership of the Bonds, and in no other way. UMB Bank, N.A. is hereby appointed as Bond Registrar under the terms of this Resolution and under the provisions of a separate agreement with the Issuer filed herewith which is made a part hereof by this reference. Registrar shall maintain the books of the Issuer for the registration of ownership of the Bonds for the payment of principal of and interest on the Bonds as provided in this Resolution. All Bonds shall be negotiable as provided in Article 8 of the Uniform Commercial Code and

Section 384.31 of the Code of Iowa, subject to the provisions for registration and transfer contained in the Bonds and in this Resolution.

b) Transfer. The ownership of any Bond may be transferred only upon the Registration Books kept for the registration and transfer of Bonds and only upon surrender thereof at the office of the Registrar together with an assignment duly executed by the holder or his duly authorized attorney in fact in such form as shall be satisfactory to the Registrar, along with the address and social security number or federal employer identification number of such transferee (or, if registration is to be made in the name of multiple individuals, of all such transferees). In the event that the address of the registered owner of a Bond (other than a registered owner which is the nominee of the broker or dealer in question) is that of a broker or dealer, there must be disclosed on the Registration Books the information pertaining to the registered owner required above. Upon the transfer of any such Bond, a new fully registered Bond, of any denomination or denominations permitted by this Resolution in aggregate principal amount equal to the unmatured and unredeemed principal amount of such transferred fully registered Bond, and bearing interest at the same rate and maturing on the same date or dates shall be delivered by the Registrar.

c) Registration of Transferred Bonds. In all cases of the transfer of the Bonds, the Registrar shall register, at the earliest practicable time, on the Registration Books, the Bonds, in accordance with the provisions of this Resolution.

d) Ownership. As to any Bond, the person in whose name the ownership of the same shall be registered on the Registration Books of the Registrar shall be deemed and regarded as the absolute owner thereof for all purposes, and payment of or on account of the principal of any such Bonds and the premium, if any, and interest thereon shall be made only to or upon the order of the registered owner thereof or his legal representative. All such payments shall be valid and effectual to satisfy and discharge the liability upon such Bond, including the interest thereon, to the extent of the sum or sums so paid.

e) Cancellation. All Bonds which have been redeemed shall not be reissued but shall be cancelled by the Registrar. All Bonds which are cancelled by the Registrar shall be destroyed and a certificate of the destruction thereof shall be furnished promptly to the Issuer; provided that if the Issuer shall so direct, the Registrar shall forward the cancelled Bonds to the Issuer.

f) Non-Presentation of Bonds. In the event any payment check, wire, or electronic transfer of funds representing payment of principal of or interest on the Bonds is returned to the Paying Agent or if any bond is not presented for payment of principal at the maturity or redemption date, if funds sufficient to pay such principal of or interest on Bonds shall have been made available to the Paying Agent for the benefit of the owner thereof, all liability of the Issuer to the owner thereof for such interest or payment of such Bonds shall forthwith cease, terminate and be completely discharged, and thereupon it shall be the duty of the Paying Agent to hold such funds, without liability for interest thereon, for the benefit of the owner of such Bonds who shall thereafter be restricted exclusively to such funds for any claim of whatever nature on his part under this

Resolution or on, or with respect to, such interest or Bonds. The Paying Agent's obligation to hold such funds shall continue for a period equal to two years and six months following the date on which such interest or principal became due, whether at maturity, or at the date fixed for redemption thereof, or otherwise, at which time the Paying Agent shall surrender any remaining funds so held to the Issuer, whereupon any claim under this Resolution by the Owners of such interest or Bonds of whatever nature shall be made upon the Issuer.

g) Registration and Transfer Fees. The Registrar may furnish to each owner, at the Issuer's expense, one bond for each annual maturity. The Registrar shall furnish additional Bonds in lesser denominations (but not less than the minimum denomination) to an owner who so requests.

Section 9. Reissuance of Mutilated, Destroyed, Stolen or Lost Bonds. In case any outstanding Bond shall become mutilated or be destroyed, stolen or lost, the Issuer shall at the request of Registrar authenticate and deliver a new Bond of like tenor and amount as the Bond so mutilated, destroyed, stolen or lost, in exchange and substitution for such mutilated Bond to Registrar, upon surrender of such mutilated Bond, or in lieu of and substitution for the Bond destroyed, stolen or lost, upon filing with the Registrar evidence satisfactory to the Registrar and Issuer that such Bond has been destroyed, stolen or lost and proof of ownership thereof, and upon furnishing the Registrar and Issuer with satisfactory indemnity and complying with such other reasonable regulations as the Issuer or its agent may prescribe and paying such expenses as the Issuer may incur in connection therewith.

Section 10. Record Date. Payments of principal and interest, otherwise than upon full redemption, made in respect of any Bond, shall be made to the registered holder thereof or to their designated agent as the same appear on the books of the Registrar on the 15th day of the month preceding the payment date. All such payments shall fully discharge the obligations of the Issuer in respect of such Bonds to the extent of the payments so made. Upon receipt of the final payment of principal, the holder of the Bond shall surrender the Bond to the Paying Agent.

Section 11. Execution, Authentication and Delivery of the Bonds. Upon the adoption of this Resolution, the Mayor and Clerk shall execute the Bonds by their manual or authorized signature and deliver the Bonds to the Registrar, who shall authenticate the Bonds and deliver the same to or upon order of the Purchaser. No Bond shall be valid or obligatory for any purpose or shall be entitled to any right or benefit hereunder unless the Registrar shall duly endorse and execute on such Bond a Certificate of Authentication substantially in the form of the Certificate herein set forth. Such Certificate upon any Bond executed on behalf of the Issuer shall be conclusive evidence that the Bond so authenticated has been duly issued under this Resolution and that the holder thereof is entitled to the benefits of this Resolution.

No Bonds shall be authenticated and delivered by the Registrar unless and until there shall have been provided the following:

1. A certified copy of the Resolution of Issuer authorizing the issuance of the Bonds;

2. A written order of Issuer signed by the Treasurer of the Issuer directing the authentication and delivery of the Bonds to or upon the order of the Purchaser upon payment of the purchase price as set forth therein;
3. The approving opinion of Ahlers & Cooney, P.C., Bond Counsel, concerning the validity and legality of all the Bonds proposed to be issued.

Section 12. Right to Name Substitute Paying Agent or Registrar. Issuer reserves the right to name a substitute, successor Registrar or Paying Agent upon giving prompt written notice to each registered bondholder.

Section 13. Form of Bond. Bonds shall be printed substantially in the form as follows:

"STATE OF IOWA"  
 "COUNTY OF SCOTT"  
 "CITY OF BETTENDORF"  
 "GENERAL OBLIGATION BOND"  
 "SERIES 2026A"  
 CORPORATE PURPOSE

Rate: \_\_\_\_\_  
 Maturity: \_\_\_\_\_  
 Bond Date: March 26, 2026  
 CUSIP No.: \_\_\_\_\_  
 "Registered"  
 Certificate No. \_\_\_\_\_  
 Principal Amount: \$ \_\_\_\_\_

The City of Bettendorf, State of Iowa, a municipal corporation organized and existing under and by virtue of the Constitution and laws of the State of Iowa (the "Issuer"), for value received, promises to pay from the source and as hereinafter provided, on the maturity date indicated above, to

(Registration panel to be completed by Registrar or Printer with name of Registered Owner).

or registered assigns, the principal sum of (enter principal amount in long form) THOUSAND DOLLARS in lawful money of the United States of America, on the maturity date shown above, only upon presentation and surrender hereof at the office of UMB Bank, N.A., Paying Agent of this issue, or its successor, with interest on the sum from the date hereof until paid at the rate per annum specified above, payable on December 1, 2026, and semiannually thereafter on the 1st day of June and December in each year.

Interest and principal shall be paid to the registered holder of the Bond as shown on the records of ownership maintained by the Registrar as of the 15th day of the month preceding such

interest payment date. Interest shall be computed on the basis of a 360-day year of twelve 30-day months.

This Bond is issued pursuant to the provisions of Sections 384.25, 384.26, 384.28 and 403.12 of the Code of Iowa, for the purpose of paying costs of construction, reconstruction and repair of streets, including resurfacing and paving improvements, grade crossing separations and approaches, including related to railroad crossing improvements; sidewalks, pedestrian underpasses and overpasses, alleys, public ground and trail right of way; acquisition and installation of traffic control devices; acquisition, construction, improvement and installation of street lighting fixtures, connections and facilities; and construction, reconstruction, enlargement, improvement and repair of bridges; aiding in the planning, undertaking and carrying out of urban renewal projects under the authority of Iowa Code chapter 403 and the Urban Renewal Plan for the I-80 Urban Renewal Area, as amended, including the Middle Road Public Pedestrian Bridge and Trails project; and constructing, equipping and furnishing a police station and related site improvements, in conformity to a Resolution of the Council of said City duly passed and approved.

Unless this certificate is presented by an authorized representative of The Depository Trust Company, a limited purpose trust company ("DTC"), to the Issuer or its agent for registration of transfer, exchange or payment, and any certificate issued is registered in the name of Cede & Co. or such other name as requested by an authorized representative of DTC (and any payment is made to Cede & Co. or to such other Issuer as is requested by an authorized representative of DTC), ANY TRANSFER, PLEDGE OR OTHER USE HEREOF FOR VALUE OR OTHERWISE BY OR TO ANY PERSON IS WRONGFUL inasmuch as the registered owner hereof, Cede & Co., has an interest herein.

Bonds maturing after June 1, 2035, may be called for optional redemption by the Issuer and paid before maturity on said date or any date thereafter, from any funds regardless of source, in whole or from time to time in part, in any order of maturity and within an annual maturity by lot. The terms of redemption shall be par, plus accrued interest to date of call.

Thirty days' written notice of redemption shall be given to the registered owner of the Bond. Failure to give written notice to any registered owner of the Bonds or any defect therein shall not affect the validity of any proceedings for the redemption of the Bonds. All bonds or portions thereof called for redemption will cease to bear interest after the specified redemption date, provided funds for their redemption are on deposit at the place of payment. Written notice will be deemed completed upon transmission to the owner of record.

If selection by lot within a maturity is required, the Registrar shall designate the Bonds to be redeemed by random selection of the names of the registered owners of the entire annual maturity until the total amount of Bonds to be called has been reached.

If less than all of a maturity is called for redemption, the Issuer will notify DTC of the particular amount of such maturity to be redeemed prior to maturity. DTC will determine by lot the amount of each Participant's interest in such maturity to be redeemed and each Participant

will then select by lot the beneficial ownership interests in such maturity to be redeemed. All prepayments shall be at a price of par plus accrued interest.

The Bonds maturing on June 1, 2045 are subject to mandatory redemption prior to maturity by application of money on deposit in the Bond Fund and shall bear interest at 4.000% per annum at a price of the portion of the principal amount thereof to be redeemed plus accrued interest at the redemption date on June 1st of each of the years in the principal amount set opposite each year in the following schedule:

Principal Amount	Maturity June 1 <sup>st</sup>
\$840,000	2043
\$880,000	2044
\$910,000	2045*

\*Final Maturity

The principal amount of Term Bonds may be reduced through the earlier optional redemption, with any partial optional redemption of the Term Bonds credited against future mandatory redemption requirements for such Term Bonds in such order as the City shall determine.

Ownership of this Bond may be transferred only by transfer upon the books kept for such purpose by UMB Bank, N.A., the Registrar. Such transfer on the books shall occur only upon presentation and surrender of this Bond at the office of the Registrar as designated below, together with an assignment duly executed by the owner hereof or his duly authorized attorney in the form as shall be satisfactory to the Registrar. Issuer reserves the right to substitute the Registrar and Paying Agent but shall, however, promptly give notice to registered Bondholders of such change. All bonds shall be negotiable as provided in Article 8 of the Uniform Commercial Code and Section 384.31 of the Code of Iowa, subject to the provisions for registration and transfer contained in the Bond Resolution.

This Bond and the series of which it forms has been issued by the City in connection with an urban renewal project as defined in Chapter 403 of the Code of Iowa, and in any suit, action or proceeding involving the validity or enforceability of any bond issued hereunder or the security therefor, such Bond shall be conclusively deemed to have been issued for such purpose and such project shall be conclusively deemed to have been planned, located and carried out in accordance with the provisions of Chapter 403 of the Code of Iowa.

And it is hereby represented and certified that all acts, conditions and things requisite, according to the laws and Constitution of the State of Iowa, to exist, to be had, to be done, or to be performed precedent to the lawful issue of this Bond, have been existent, had, done and performed as required by law; that provision has been made for the levy of a sufficient continuing annual tax on all the taxable property within the territory of the Issuer for the payment of the principal and interest of this Bond as the same will respectively become due; that such

taxes have been irrevocably pledged for the prompt payment hereof, both principal and interest; and the total indebtedness of the Issuer including this Bond, does not exceed the constitutional or statutory limitations.

IN TESTIMONY WHEREOF, the Issuer by its Council, has caused this Bond to be signed by the manual or facsimile signature of its Mayor and attested by the manual or facsimile signature of its City Clerk, with the seal of the City printed or impressed hereon, and to be authenticated by the manual signature of an authorized representative of the Registrar, UMB Bank, N.A., West Des Moines, Iowa.

Date of authentication: March 26, 2026  
This is one of the Bonds described in the within mentioned Resolution, as registered by UMB Bank, N.A.

UMB BANK, N.A., Registrar

By: \_\_\_\_\_  
Authorized Signature  
Registrar and Transfer Agent: UMB Bank, N.A.  
Paying Agent: UMB Bank, N.A.

SEE REVERSE FOR CERTAIN DEFINITIONS

(Seal)  
(Signature Block)

CITY OF BETTENDORF, STATE OF IOWA

By: \_\_\_\_\_ (manual or facsimile signature) \_\_\_\_\_  
Mayor

ATTEST:

By: \_\_\_\_\_ (manual or facsimile signature) \_\_\_\_\_  
City Clerk

(Information Required for Registration)

ASSIGNMENT

For value received, the undersigned hereby sells, assigns and transfers unto \_\_\_\_\_ (Social Security or Tax Identification No. \_\_\_\_\_) the within Bond and does hereby irrevocably constitute and appoint \_\_\_\_\_ attorney in fact to transfer the said Bond on the books kept for registration of the within Bond, with full power of substitution in the premises.

Dated: \_\_\_\_\_

\_\_\_\_\_

\_\_\_\_\_  
(Person(s) executing this Assignment sign(s) here)

SIGNATURE )  
GUARANTEED) \_\_\_\_\_

IMPORTANT - READ CAREFULLY

The signature(s) to this Power must correspond with the name(s) as written upon the face of the certificate(s) or bond(s) in every particular without alteration or enlargement or any change whatever. Signature guarantee must be provided in accordance with the prevailing standards and procedures of the Registrar and Transfer Agent. Such standards and procedures may require signature to be guaranteed by certain eligible guarantor institutions that participate in a recognized signature guarantee program.

INFORMATION REQUIRED FOR REGISTRATION OF TRANSFER

Name of Transferee(s) \_\_\_\_\_

Address of Transferee(s) \_\_\_\_\_

Social Security or Tax Identification \_\_\_\_\_

Number of Transferee(s) \_\_\_\_\_

Transferee is a(n):

Individual\* \_\_\_\_\_

Corporation \_\_\_\_\_

Partnership \_\_\_\_\_

Trust \_\_\_\_\_

\*If the Bond is to be registered in the names of multiple individual owners, the names of all such owners and one address and social security number must be provided.

The following abbreviations, when used in the inscription on the face of this Bond, shall be construed as though written out in full according to applicable laws or regulations:

TEN COM - as tenants in common

TEN ENT - as tenants by the entireties

JT TEN - as joint tenants with rights of survivorship and not as tenants in common

IA UNIF TRANS MIN ACT - ..... Custodian .....  
(Cust) (Minor)  
Under Iowa Uniform Transfers to Minors Act.....  
(State)

ADDITIONAL ABBREVIATIONS MAY  
ALSO BE USED THOUGH NOT IN THE ABOVE LIST

(End of form of Bond)

Section 14. Closing Documents. The Mayor and City Clerk are authorized and directed to execute, attest, seal and deliver for and on behalf of the City any other additional certificates, documents, or other papers and perform all other acts, including without limitation the execution of all closing documents, as they may deem necessary or appropriate in order to implement and carry out the intent and purposes of this Resolution.

Section 15. Contract Between Issuer and Purchaser. This Resolution constitutes a contract between said City and the purchaser of the Bonds.

Section 16. Non-Arbitrage Covenants. The Issuer reasonably expects and covenants that no use will be made of the proceeds from the issuance and sale of the Bonds issued hereunder which will cause any of the Bonds to be classified as arbitrage bonds within the meaning of Sections 148(a) and (b) of the Internal Revenue Code of the United States, as amended, and that throughout the term of the Bonds it will comply with the requirements of statutes and regulations issued thereunder.

To the best knowledge and belief of the Issuer, there are no facts or circumstances that would materially change the foregoing statements or the conclusion that it is not expected that the proceeds of the Bonds will be used in a manner that would cause the Bonds to be arbitrage bonds.

Section 17. Approval of Tax Exemption Certificate. Attached hereto is a form of Tax Exemption Certificate stating the Issuer's reasonable expectations as to the use of the proceeds of the Bonds. The form of Tax Exemption Certificate is approved. The Issuer hereby agrees to comply with the provisions of the Tax Exemption Certificate and the provisions of the Tax Exemption Certificate are hereby incorporated by reference as part of this Resolution. The Finance Director is hereby directed to make and insert all calculations and determinations necessary to complete the Tax Exemption Certificate at issuance of the Bonds to certify as to the reasonable expectations and covenants of the Issuer at that date.

Section 18. Continuing Disclosure. The Issuer hereby covenants and agrees that it will comply with and carry out all of the provisions of the Continuing Disclosure Certificate, and the provisions of the Continuing Disclosure Certificate are hereby incorporated by reference as part of this Resolution and made a part hereof. Notwithstanding any other provision of this Resolution, failure of the Issuer to comply with the Continuing Disclosure Certificate shall not be considered an event of default under this Resolution; however, any holder of the Bonds or

Beneficial Owner may take such actions as may be necessary and appropriate, including seeking specific performance by court order, to cause the Issuer to comply with its obligations under the Continuing Disclosure Certificate. For purposes of this section, "Beneficial Owner" means any person which (a) has the power, directly or indirectly, to vote or consent with respect to, or to dispose of ownership of, any Bond (including persons holding Bonds through nominees, depositories or other intermediaries), or (b) is treated as the owner of any Bonds for federal income tax purposes.

Section 19. Additional Covenants, Representations and Warranties of the Issuer. The Issuer certifies and covenants with the purchasers and holders of the Bonds from time to time outstanding that the Issuer through its officers, (a) will make such further specific covenants, representations and assurances as may be necessary or advisable; (b) comply with all representations, covenants and assurances contained in the Tax Exemption Certificate, which Tax Exemption Certificate shall constitute a part of the contract between the Issuer and the owners of the Bonds;(c) consult with Bond Counsel (as defined in the Tax Exemption Certificate); (d) pay to the United States, as necessary, such sums of money representing required rebates of excess arbitrage profits relating to the Bonds;(e) file such forms, statements and supporting documents as may be required and in a timely manner; and (f) if deemed necessary or advisable by its officers, to employ and pay fiscal agents, financial advisors, attorneys and other persons to assist the Issuer in such compliance.

Section 20. Amendment of Resolution to Maintain Tax Exemption. This Resolution may be amended without the consent of any owner of the Bonds if, in the opinion of Bond Counsel, such amendment is necessary to maintain tax exemption with respect to the Bonds under applicable Federal law or regulations.

Section 21. Repeal of Conflicting Resolutions or Ordinances. All ordinances and resolutions and parts of ordinances and resolutions in conflict herewith are hereby repealed.

Section 22. Severability Clause. If any section, paragraph, clause or provision of this Resolution be held invalid, such invalidity shall not affect any of the remaining provisions hereof, and this Resolution shall become effective immediately upon its passage and approval.

PASSED AND APPROVED this 3<sup>rd</sup> day of March, 2026.

---

Mayor

ATTEST:

---

City Clerk

CERTIFICATE

STATE OF IOWA )  
 ) SS  
COUNTY OF SCOTT )

I, the undersigned City Clerk of the City of Bettendorf, State of Iowa, do hereby certify that attached is a true and complete copy of the portion of the records of the City showing proceedings of the Council, and the same is a true and complete copy of the action taken by the Council with respect to the matter at the meeting held on the date indicated in the attachment, which proceedings remain in full force and effect, and have not been amended or rescinded in any way; that meeting and all action thereat was duly and publicly held in accordance with a notice of meeting and tentative agenda, a copy of which was timely served on each member of the Council and posted on a bulletin board or other prominent place easily accessible to the public and clearly designated for that purpose at the principal office of the Council pursuant to the local rules of the Council and the provisions of Chapter 21, Code of Iowa, upon reasonable advance notice to the public and media at least twenty-four hours prior to the commencement of the meeting as required by law and with members of the public present in attendance; I further certify that the individuals named therein were on the date thereof duly and lawfully possessed of their respective City offices as indicated therein, that no Council vacancy existed except as may be stated in the proceedings, and that no controversy or litigation is pending, prayed or threatened involving the incorporation, organization, existence or boundaries of the City or the right of the individuals named therein as officers to their respective positions.

WITNESS my hand and the seal of the Council hereto affixed this \_\_\_\_\_ day of \_\_\_\_\_, 2026.

\_\_\_\_\_  
City Clerk, City of Bettendorf, State of Iowa

(SEAL)

---

TAX EXEMPTION CERTIFICATE

of

CITY OF BETTENDORF, COUNTY OF SCOTT, STATE OF IOWA, ISSUER

\$19,745,000 General Obligation Bonds, Series 2026A

---

This instrument was prepared by:

Ahlers & Cooney, P.C.  
100 Court Avenue, Suite 600  
Des Moines, Iowa 50309  
(515) 243-7611

TABLE OF CONTENTS

This Table of Contents is not a part of this Tax Exemption Certificate and is provided only for convenience of reference.

**INTRODUCTION..... - 1 -**

**ARTICLE I DEFINITIONS ..... - 1 -**

**ARTICLE II SPECIFIC CERTIFICATIONS, REPRESENTATIONS AND AGREEMENTS ..... - 4 -**

    Section 2.1 Authority to Certify and Expectations ..... - 5 -

    Section 2.2 Receipts and Expenditures of Sale Proceeds ..... - 7 -

    Section 2.3 Purpose of Bonds ..... - 7 -

    Section 2.4 Facts Supporting Tax-Exemption Classification ..... - 7 -

    Section 2.5 Facts Supporting Temporary Periods for Proceeds ..... - 8 -

    Section 2.6 Resolution Funds at Restricted or Unrestricted Yield ..... - 8 -

    Section 2.7 Pertaining to Yields..... - 9 -

    Section 2.8 Reimbursement Bonds ..... - 9 -

**ARTICLE III REBATE ..... - 11 -**

    Section 3.1 Records ..... - 11 -

    Section 3.2 Rebate Fund ..... - 11 -

    Section 3.3 Exceptions to Rebate..... - 11 -

    Section 3.4 Calculation of Rebate Amount..... - 13 -

    Section 3.5 Rebate Requirements and the Bond Fund..... - 13 -

    Section 3.6 Investment of the Rebate Fund ..... - 13 -

    Section 3.7 Payment to the United States ..... - 13 -

    Section 3.8 Records ..... - 14 -

    Section 3.9 Additional Payments ..... - 14 -

**ARTICLE IV INVESTMENT RESTRICTIONS..... - 15 -**

    Section 4.1 Avoidance of Prohibited Payments..... - 15 -

    Section 4.2 Market Price Requirement ..... - 15 -

    Section 4.3 Investment in Certificates of Deposit ..... - 15 -

    Section 4.4 Investment Pursuant to Investment Contracts and Agreements ..... - 16 -

    Section 4.5 Records ..... - 18 -

    Section 4.6 Investments to be Legal ..... - 18 -

**ARTICLE V GENERAL COVENANTS ..... - 18 -**

**ARTICLE VI AMENDMENTS AND ADDITIONAL AGREEMENTS ..... - 18 -**

    Section 6.1 Opinion of Bond Counsel; Amendments..... - 18 -

    Section 6.2 Additional Covenants, Agreements ..... - 19 -

    Section 6.3 Internal Revenue Service Audits ..... - 19 -

    Section 6.4 Amendments ..... - 19 -

**EXHIBIT "A" .....20**

**EXHIBIT "B" .....29**

## TAX EXEMPTION CERTIFICATE

### CITY OF BETTENDORF, STATE OF IOWA

THIS TAX EXEMPTION CERTIFICATE made and entered into on March 26, 2026, by the City of Bettendorf, County of Scott, State of Iowa (the "Issuer").

#### INTRODUCTION

This Certificate is executed and delivered in connection with the issuance by the Issuer of its \$19,745,000 General Obligation Bonds, Series 2026A (the "Bonds"). The Bonds are issued pursuant to the provisions of the Resolution of the Issuer authorizing the issuance of the Bonds. Such Resolution provides that the covenants contained in this Certificate constitute a part of the Issuer's contract with the owners of the Bonds.

The Issuer recognizes that under the Code (as defined below) the tax-exempt status of the interest received by the owners of the Bonds is dependent upon, among other things, the facts, circumstances, and reasonable expectations of the Issuer as to future facts not in existence at this time, as well as the observance of certain covenants in the future. The Issuer covenants that it will take such action with respect to the Bonds as may be required by the Code, and pertinent legal regulations issued thereunder in order to establish and maintain the tax-exempt status of the Bonds, including the observance of all specific covenants contained in the Resolution and this Certificate.

#### ARTICLE I

##### DEFINITIONS

The following terms as used in this Certificate shall have the meanings set forth below. The terms defined in the Resolution shall retain the meanings set forth therein when used in this Certificate. Other terms used in this Certificate shall have the meanings set forth in the Code or in the Regulations.

- "Annual Debt Service" means the principal of and interest on the Bonds scheduled to be paid during a given Bond Year.
- "Bonds" means the \$19,745,000 aggregate principal amount of General Obligation Bonds, Series 2026A, of the Issuer issued in registered form pursuant to the Resolution.
- "Bond Counsel" means Ahlers & Cooney, P.C., Des Moines, Iowa, or an attorney at law or a firm of attorneys of nationally recognized standing in matters pertaining to the tax-exempt status of interest on obligations issued by states and their political subdivisions, duly admitted to the practice of law before the highest court of any State of the United States of America.
- "Bond Fund" means the Sinking Fund described in the Resolution.

- "Bond Purchase Agreement" means the binding contract in writing for the sale of the Bonds.
- "Bond Year" as defined in Regulation 1.148-1(b), means a one-year period beginning on the day after expiration of the preceding Bond Year. The first Bond Year shall be the one-year or shorter period beginning on the Closing Date and ending on a principal or interest payment date, unless Issuer selects another date.
- "Bond Yield" means that discount rate which produces an amount equal to the Issue Price of the Bonds when used in computing the present value of all payments of principal and interest to be paid on the Bonds, using semiannual compounding on a 360-day year as computed under Regulation 1.148-4.
- "Certificate" means this Tax Exemption Certificate.
- "Closing" means the delivery of the Bonds in exchange for the agreed upon purchase price.
- "Closing Date" means the date of Closing.
- "Code" means the Internal Revenue Code of 1986, as amended, and any statutes which replace or supplement the Internal Revenue Code of 1986.
- "Computation Date" means each five-year period from the Closing Date through the last day of the fifth and each succeeding fifth Bond Year.
- "Excess Earnings" means the amount earned on all Nonpurpose Investments minus the amount which would have been earned if such Nonpurpose Investments were invested at a rate equal to the Bond Yield, plus any income attributable to such excess.
- "Final Bond Retirement Date" means the date on which the Bonds are actually paid in full.
- "Governmental Obligations" means direct general obligations of, or obligations the timely payment of the principal of and interest on which is unconditionally guaranteed by the United States.
- "Gross Proceeds" as defined in Regulation 1.148-1(b), means any Proceeds of the Bonds and any replacement proceeds (as defined in Regulation 1.148-1(c)) of the Bonds.
- "Gross Proceeds Funds" means the Project Fund, Proceeds held to pay cost of issuance, and any other fund or account held for the benefit of the owners of the Bonds or containing Gross Proceeds of the Bonds except the Bond Fund and the Rebate Fund.

- "Issue Price" as defined in Regulation 1.148-1(b) and (f)(2), means the price determined pursuant to the Special Rule for Competitive Sales in accordance with Regulation 1.148-1(f)(2)(iii). The Issuer hereby elects to utilize the Special Rule for Competitive Sales and treats the reasonably expected initial offering price to the public as of the sale date as the issue price of the Bonds. The Purchasers have certified the Issue Price to be not more than \$22,115,351.60, as set forth in Exhibit A.
- "Issuer" means the City of Bettendorf, a municipal corporation in the County of Scott, State of Iowa.
- "Minor Portion of the Bonds", as defined in Regulation 1.148-2(g), means the lesser of five (5) percent of Proceeds or \$100,000. The Minor Portion of the Bonds is computed to be \$100,000.
- "Nonpurpose Investments" means any investment property which is acquired with Gross Proceeds and is not acquired to carry out the governmental purpose of the Bonds, and may include but is not limited to U.S. Treasury bonds, corporate bonds, or certificates of deposit.
- "Proceeds" as defined in Regulation 1.148-1(b), means Sale Proceeds, investment proceeds and transferred proceeds of the Bonds.
- "Project" means the construction, reconstruction and repair of streets, including resurfacing and paving improvements, grade crossing separations and approaches, including related to railroad crossing improvements; sidewalks, pedestrian underpasses and overpasses, alleys, public ground and trail right of way; acquisition and installation of traffic control devices; acquisition, construction, improvement and installation of street lighting fixtures, connections and facilities; and construction, reconstruction, enlargement, improvement and repair of bridges; aiding in the planning, undertaking and carrying out of urban renewal projects under the authority of Iowa Code chapter 403 and the Urban Renewal Plan for the I-80 Urban Renewal Area, as amended, including the Middle Road Public Pedestrian Bridge and Trails project; and constructing, equipping and furnishing a police station and related site improvements including sums already expended that meet the requirements of Section 2.8 hereof, as more fully described in the Resolution.
- "Project Fund" shall mean the fund required to be established by the Resolution for the deposit of the Proceeds of the Bonds.
- "Purchasers" means Piper Sandler & Co. of Minneapolis, Minnesota, constituting the initial purchasers of the Bonds from the Issuer.
- "Rebate Amount" means the amount computed as described in this Certificate.
- "Rebate Fund" means the fund to be created, if necessary, pursuant to this Certificate.

- "Rebate Payment Date" means a date chosen by the Issuer which is not more than 60 days following each Computation Date or the Final Bond Retirement Date.
- "Regulations" means the Income Tax Regulations, amendments and successor provisions promulgated by the Department of the Treasury under Sections 103, 148 and 149 of the Code, or other Sections of the Code relating to "arbitrage bonds", including without limitation Regulations 1.148-1 through 1.148-11, 1.149(b)-1, 1.149-d(1), 1.150-1 and 1.150-2.
- "Replacement Proceeds" include, but are not limited to, sinking funds, amounts that are pledged as security for an issue, and amounts that are replaced because of a sufficiently direct nexus to a governmental purpose of an issue.
- "Resolution" means the resolution of the Issuer adopted on March 3, 2026, authorizing the issuance of the Bonds.
- "Sale Proceeds" as defined in Regulation 1.148-1(b), means any amounts actually or constructively received from the sale of the Bonds, including amounts used to pay underwriter's discount or compensation and accrued interest other than pre-issuance accrued interest.
- "Sinking Fund" means the Bond Fund.
- "SLGS" means demand deposit Treasury securities of the State and Local Government Series.
- "Tax Exempt Obligations" means bonds or other obligations the interest on which is excludable from the gross income of the owners thereof under Section 103 of the Code and include certain regulated investment companies, stock in tax-exempt mutual funds and demand deposit SLGS.
- "Taxable Obligations" means all investment property, obligations or securities other than Tax Exempt Obligations.
- "Verification Certificate" means the certificate attached to this Certificate as Exhibit A, setting forth the offering prices at which the Purchaser will reoffer and sell the Bonds to the public.

## ARTICLE II

### SPECIFIC CERTIFICATIONS, REPRESENTATIONS AND AGREEMENTS

The Issuer hereby certifies, represents and agrees as follows:

Section 2.1 Authority to Certify and Expectations

(a) The undersigned officer of the Issuer along with other officers of the Issuer, are charged with the responsibility of issuing the Bonds.

(b) This Certificate is being executed and delivered in part for the purposes specified in Section 1.148-2(b)(2) of the Regulations and is intended (among other purposes) to establish reasonable expectations of the Issuer at this time.

(c) The Issuer has not been notified of any disqualification or proposed disqualification of it by the Commissioner of the Internal Revenue Service as a bond issuer which may certify bond issues under Section 1.148-2(b)(2) of the Regulations.

(d) The certifications, representations and agreements set forth in this Article II are made on the basis of the facts, estimates and circumstances in existence on the date hereof, including the following: (1) with respect to amounts expected to be received from delivery of the Bonds, amounts actually received, (2) with respect to payments of amounts into various funds or accounts, review of the authorizations or directions for such payments made by the Issuer pursuant to the Resolution and this Certificate, (3) with respect to the Issue Price, the certifications of the Purchasers as set forth in the Verification Certificate, (4) with respect to expenditure of the Proceeds of the Bonds, actual expenditures and reasonable expectations of the Issuer as to when the Proceeds will be spent for purposes of the Project, and (5) with respect to Bond Yield, review of the Verification Certificate. The Issuer has no reason to believe such facts, estimates or circumstances are untrue or incomplete in any material way.

(e) To the best of the knowledge and belief of the undersigned officer of the Issuer, there are no facts, estimates or circumstances that would materially change the representations, certifications or agreements set forth in this Certificate, and the expectations herein set out are reasonable.

(f) No arrangement exists under which the payment of principal or interest on the Bonds would be directly or indirectly guaranteed by the United States or any agency or instrumentality thereof.

(g) After the expiration of any applicable temporary periods, and excluding investments in a bona fide debt service fund or reserve fund, not more than five percent (5%) of the Proceeds of the Bonds will be (a) used to make loans which are guaranteed by the United States or any agency or instrumentality thereof, or (b) invested in federally insured deposits or accounts.

(h) The Issuer will file with the Internal Revenue Service in a timely fashion Form 8038-G, Information Return for Tax-Exempt Governmental Obligations with respect to the Bonds and such other reports required to comply with the Code and applicable Regulations.

(i) The Issuer will take no action which would cause the Bonds to become "private activity bonds" as defined in Section 141 (a) of the Code, including any use of

the Project by any person other than a governmental unit if such use will be by other than a member of the general public. None of the Proceeds of the Bonds will be used directly or indirectly to make or finance loans to any person other than a governmental unit.

(j) The Issuer will make no change in the nature or purpose of the Project except as provided in Section 6.1 hereof.

(k) Except as provided in the Resolution, the Issuer will not establish any sinking fund, bond fund, reserve fund, debt service fund or other fund reasonably expected to be used to pay debt service on the Bonds (other than the Bond Fund and any Reserve Fund), exercise its option to redeem Bonds prior to maturity or effect a refunding of the Bonds.

(l) No bonds or other obligations of the Issuer (1) were sold in the 15 days preceding the date of sale of the Bonds, (2) were sold or will be sold within the 15 days after the date of sale of the Bonds, (3) have been delivered in the past 15 days or (4) will be delivered in the next 15 days pursuant to a common plan of financing for the issuance of the Bonds and payable out of substantially the same source of revenues.

(m) None of the Proceeds of the Bonds will be used directly or indirectly to replace funds of the Issuer used directly or indirectly to acquire obligations having a yield higher than the Bond Yield.

(n) No portion of the Bonds is issued for the purpose of investing such portion at a higher yield than the Bond Yield.

(o) The Issuer does not expect that the Proceeds of the Bonds will be used in a manner that would cause them to be "arbitrage bonds" as defined in Section 148(a) of the Code. The Issuer does not expect that the Proceeds of the Bonds will be used in a manner that would cause the interest on the Bonds to be includible in the gross income of the owners of the Bonds under the Code. The Issuer will not intentionally use any portion of the Proceeds to acquire higher yielding investments.

(p) The Issuer will not use the Proceeds of the Bonds to exploit the difference between tax-exempt and taxable interest rates to obtain a material financial advantage.

(q) The Issuer has not issued more Bonds, issued the Bonds earlier, or allowed the Bonds to remain outstanding longer than is reasonably necessary to accomplish the governmental purposes of the Bonds and in fact, the Bonds will not remain outstanding longer than 120% of the economic useful life of the assets financed with the Proceeds of the Bonds.

(r) The Bonds will not be Hedge Bonds as described in Section 149(g)(3) of the Code because the Issuer reasonably expects that it will meet the Expenditure test set forth in Section 2.5(b) hereof and that 50% or more of the Proceeds will not be invested in Nonpurpose Investments having a substantially guaranteed yield for four or more years.

Except for costs of issuance, all Sale Proceeds and investment earnings thereon will be expended for costs of the type that would be chargeable to capital accounts under the Code pursuant to federal income tax principles if the Issuer were treated as a corporation subject to federal income taxation.

#### Section 2.2 Receipts and Expenditures of Sale Proceeds

Sale Proceeds (par plus re-offering premium of \$2,370,351.60), less underwriter's discount of \$64,082.86, received at Closing are expected to be deposited and expended as follows:

- (a) \$104,587 representing costs of issuing the Bonds will be used within six months of the Closing Date to pay the costs of issuance of the Bonds (with any excess remaining on deposit in the Project Fund); and
- (b) \$21,946,681.74 will be deposited into the Project Fund and will be used together with earnings thereon to pay the costs of the Project and will not exceed the amount necessary to accomplish the governmental purposes of the Bonds.

#### Section 2.3 Purpose of Bonds

The Issuer is issuing the Bonds to pay the costs of construction, reconstruction and repair of streets, including resurfacing and paving improvements, grade crossing separations and approaches, including related to railroad crossing improvements; sidewalks, pedestrian underpasses and overpasses, alleys, public ground and trail right of way; acquisition and installation of traffic control devices; acquisition, construction, improvement and installation of street lighting fixtures, connections and facilities; and construction, reconstruction, enlargement, improvement and repair of bridges; aiding in the planning, undertaking and carrying out of urban renewal projects under the authority of Iowa Code chapter 403 and the Urban Renewal Plan for the I-80 Urban Renewal Area, as amended, including the Middle Road Public Pedestrian Bridge and Trails project; and constructing, equipping and furnishing a police station and related site improvements.

#### Section 2.4 Facts Supporting Tax-Exemption Classification

##### Governmental Bonds

##### Private Business Use/Private Security or Payment Tests

The Bonds are considered to be governmental bonds. The Proceeds will be used for the purposes described in Section 2.3 hereof. These bonds are not private activity bonds because no amount of Proceeds of the Bonds is to be used in a trade or business carried on by a non-governmental unit to the extent which would create excessive private activity over the life of the Bonds so as to cause the Bonds to be private activity bonds. Rather, the Proceeds will be used to finance the general government operations and facilities of the Issuer described in Section 2.3 hereof. None of the payment of principal or interest on the Bonds will be derived from, or secured by, money or property used in a trade or business of a non-governmental unit. In addition, none of the governmental

operations or facilities of the Issuer being financed with the Proceeds of the Bonds are subject to any lease, management contract or other similar arrangement or to any arrangement for use other than as by the general public.

#### Private Loan Financing Test

No amount of Proceeds of the Bonds is to be used directly or indirectly to make or finance loans to persons other than governmental units.

#### Section 2.5 Facts Supporting Temporary Periods for Proceeds

(a) Time Test. Not later than six months after the Closing Date, the Issuer will incur a substantial binding obligation to a third party to expend at least 5% of the net Sale Proceeds of the Bonds.

(b) Expenditure Test. Not less than 85% of the net Sale Proceeds will be expended for Project costs, including the reimbursement of other funds expended to date, within a three-year temporary period from the Closing Date.

(c) Due Diligence Test. Not later than six months after Closing, work on the Project will have commenced and will proceed with due diligence to completion.

(d) Proceeds of the Bonds representing less than six months accrued interest on the Bonds will be spent within six months of this date to pay interest on the Bonds, and will be invested without restriction as to yield for a temporary period not in excess of six months.

#### Section 2.6 Resolution Funds at Restricted or Unrestricted Yield

(a) Proceeds of the Bonds will be held and accounted for in the manner provided in the Resolution. The Issuer has not and does not expect to create or establish any other bond fund, reserve fund, or similar fund or account for the Bonds. The Issuer has not and will not pledge any moneys or Taxable Obligations in order to pay debt service on the Bonds or restrict the use of such moneys or Taxable Obligations so as to give reasonable assurances of their availability for such purposes.

(b) Any monies which are invested beyond a temporary period are expected to constitute less than a major portion of the Bonds or to be restricted for investment at a yield not greater than one-eighth of one percent above the Bond Yield.

(c) The Issuer has established and will use the Bond Fund primarily to achieve a proper matching of revenues and debt service within each Bond Year and the Issuer will apply moneys deposited into the Bond Fund to pay the principal of and interest on the Bonds. Such Fund will be depleted at least once each Bond Year except for a reasonable carryover amount. The carryover amount will not exceed the greater of (1) one year's earnings on the Bond Fund or (2) one-twelfth of Annual Debt Service. The Issuer will spend moneys deposited from time to time into such fund within 13 months after the date of deposit. Revenues, intended to be used to pay debt service on the Bonds,

will be deposited into the Bond Fund as set forth in the Resolution. The Issuer will spend interest earned on moneys in such fund not more than 12 months after receipt. Accordingly, the Issuer will treat the Bond Fund as a bona fide debt service fund as defined in Regulation 1.148-1(b).

Investment of amounts on deposit in the Bond Fund will not be subject to arbitrage rebate requirements as the Bonds meet the safe harbor set forth in Regulation 1.148-3(k), because the average annual debt service on the Bonds will not exceed \$2,500,000; the Bonds meet the safe harbor set forth in Code Section 148(f)(4)(A) because the Bonds are not private activity bonds, the average maturity of the issue (determined in accordance with Code Section 147(b)(2)(A)) is at least 5 years and the rates of interest on the bonds which are part of the issue do not vary during the term of the issue; and the Bonds are expected to meet one or more of the spending exemptions from rebate as provided in Section 3.3 hereof.

(d) The Minor Portion of the Bonds will be invested without regard to yield.

#### Section 2.7 Pertaining to Yields

(a) The purchase price of all Taxable Obligations to which restrictions apply under this Certificate as to investment yield or rebate of Excess Earnings, if any, has been and shall be calculated using (i) the price taking into account discount, premium and accrued interest, as applicable, actually paid or (ii) the fair market value if less than the price actually paid and if such Taxable Obligations were not purchased directly from the United States Treasury. The Issuer will acquire all such Taxable Obligations directly from the United States Treasury or in an arm's length transaction without regard to any amounts paid to reduce the yield on such Taxable Obligations. The Issuer will not pay or permit the payment of any amounts (other than to the United States) to reduce the yield on any Taxable Obligations. Obligations pledged to the payment of debt service on the Bonds, or deposited into any reserve fund after they have been acquired by the Issuer will be treated as though they were acquired for their fair market value on the date of such pledge or deposit. Obligations on deposit in any reserve fund on the Closing Date shall be treated as if acquired for their fair market value on the Closing Date.

(b) Qualified guarantees have not been used in computing yield.

(c) The Bond Yield has been computed as not less than 3.054235% percent. This Bond Yield has been computed on the basis of a purchase price for the Bonds equal to the Issue Price.

#### Section 2.8 Reimbursement Bonds

(a) Not later than 60 days after payment of Original Expenditures, the Issuer has adopted an Official Intent and has declared its intention to make a Reimbursement Allocation of Original Expenditures incurred in connection with Project Segment(s) from proceeds of the Reimbursement Bonds.

(b) The Reimbursement Allocation will occur on or before the later of (i) eighteen months after the Original Expenditures are paid or (ii) eighteen months after the first Project Segment is placed in service, but in no event more than three years after the Original Expenditures are paid.

(c) No other Reimbursement Allocation will be made except for Preliminary Expenditures.

(d) The Reimbursement Allocation has not been undertaken to avoid, in whole or in part, arbitrage yield restrictions or arbitrage rebate requirements and will not employ an abusive arbitrage device under Regulation 1.148-10.

(e) Within one year of the Closing Date, the Reimbursement Allocation will not be used in a manner that results in the creation of replacement proceeds, as defined in Regulation 1.148-1.

(f) For purposes of Section 2.8, the following terms shall have the meanings set forth below:

(1) "Official Intent" means a declaration of intent described under Regulation 1.150-2 to reimburse Original Expenditures with the proceeds of the Bonds.

(2) "Original Expenditure" means an expenditure for a governmental purpose that is originally paid from a source other than the Reimbursement Bonds.

(3) "Preliminary Expenditures", as defined in Regulation 1.150-2(f)(2), means architectural, engineering, surveying, soil tests, Reimbursement Bond issuance costs, and similar costs incurred prior to commencement of construction, rehabilitation or acquisition of a Project Segment which do not exceed 20% of the Issue Price of the portion of the Bonds that finances the Project Segment for which they were incurred.

(4) "Project Segment" means the costs, described in an Official Intent of the Issuer, incurred prior to the Closing Date to acquire, construct, or improve land, buildings or equipment excluding current operating expenses but including costs of issuing the Reimbursement Bonds.

(5) "Reimbursement Allocation" means written evidence of the use of Reimbursement Bond proceeds to reimburse a fund of the Issuer for Original Expenditures paid or advanced prior to the Closing Date and incurred in connection with a Project Segment.

(6) "Reimbursement Bonds" means the portion of the Bonds which are allocated to reimburse the Original Expenditures paid prior to the Closing Date and incurred in connection with a Project Segment.

## ARTICLE III

### REBATE

#### Section 3.1 Records

Sale Proceeds of the Bonds will be held and accounted for in the manner provided in the Resolution. The Issuer will maintain adequate records for funds created by the Resolution and this Certificate including all deposits, withdrawals, transfers from, transfers to, investments, reinvestments, sales, purchases, redemptions, liquidations and use of money or obligations until six years after the Final Bond Retirement Date.

#### Section 3.2 Rebate Fund

(a) In the Resolution, the Issuer has covenanted to pay to the United States the Rebate Amount, an amount equal to the Excess Earnings on the Gross Proceeds Funds, if any, at the times and in the manner required or permitted and subject to stated special rules and allowable exceptions.

(b) The Issuer may establish a fund pursuant to the Resolution and this Certificate which is herein referred to as the Rebate Fund. The Issuer will invest and expend amounts on deposit in the Rebate Fund in accordance with this Certificate.

(c) Moneys in the Rebate Fund shall be held by the Issuer or its designee and, subject to Sections 3.4, 3.5 and 6.1 hereof, shall be held for future payment to the United States as contemplated under the provisions of this Certificate and shall not constitute part of the trust estate held for the benefit of the owners of the Bonds or the Issuer.

(d) The Issuer will pay to the United States from legally available money of the Issuer (whether or not such available money is on deposit in any fund or account related to the Bonds) any amount which is required to be paid to the United States.

#### Section 3.3 Exceptions to Rebate

The Issuer reasonably expects that the Bonds are eligible for one or more exceptions from the arbitrage rebate rules set forth in the Regulations. If any Proceeds are ineligible, or become ineligible, for an exception to the arbitrage rebate rules, the Issuer will comply with the provisions of this Article III. A description of the applicable rebate exception(s) is as follows:

- Eighteen-Month Exception

The Gross Proceeds of the Bonds are expected to be expended for the governmental purposes for which the Bonds were issued in accordance with the following schedule:

- 1) 15 percent spent within six months of the Closing Date;
- 2) 60 percent spent within one year of the Closing Date;

- 3) 100 percent spent within eighteen months of the Closing Date (subject to 5 percent retainage for not more than one year).

In any event, the Issuer expects that the 5% reasonable retainage will be spent within 30 months of the Closing Date. For purposes of determining compliance with the six-month and twelve-month spending periods, the amount of investment earnings included shall be based on the Issuer's reasonable expectations that the average annual interest rate on investments will be not more than 1.79%. For purposes of determining compliance with the eighteen-month spending period, the amount of investment earnings included shall be based on actual earnings. If the Issuer fails to meet the foregoing expenditure schedule, the Issuer shall comply with the arbitrage rebate requirements of the Code.

- Election to Treat as Construction Bonds.

The Issuer reasonably expects that more than 75 percent of the "available construction proceeds" ("ACP") of the Bonds, as defined in Section 148(f)(4)(C)(vi) of the Code, will be used for construction expenditures. ACP includes the issue price of the issue plus the earnings on such issue. Not less than the following percentages of the ACP will be spent within the following periods:

- 1) 10 percent spent within six months of the Closing Date;
- 2) 45 percent spent within one year of the Closing Date;
- 3) 75 percent spent within eighteen months of the Closing Date;
- 4) 100 percent spent within two years of the Closing Date (subject to 5 percent retainage for not more than one year).

In any event, the Issuer expects that the 5% reasonable retainage will be spent within a three-year period beginning on the Closing Date. A failure to spend an amount that does not exceed the lesser of (i) 3% of the issue price or (ii) \$250,000, is disregarded if the Issuer exercises due diligence to complete the Project.

- Election with respect to future earnings

Pursuant to Section 1.148-7(h)(i)(3) of the Regulations, the Issuer shall calculate the amount of future earnings to be used in determining compliance with the first three spending periods based on its reasonable expectations that the average annual interest rate on investments of the ACP will be not more than 1.79%. Compliance with the final spending period shall be calculated using actual earnings.

If the Issuer fails to meet the foregoing expenditure schedule, the Issuer shall comply with the arbitrage rebate requirements of the Code.

#### Section 3.4 Calculation of Rebate Amount

(a) As soon after each Computation Date as practicable, the Issuer shall, if necessary, calculate and determine the Excess Earnings on the Gross Proceeds Funds (the "Rebate Amount"). All calculations and determinations with respect to the Rebate Amount will be made on the basis of actual facts as of the Computation Date and reasonable expectations as to future events.

(b) If the Rebate Amount exceeds the amount currently on deposit in the Rebate Fund, the Issuer may deposit an amount in the Rebate Fund such that the balance in the Rebate Fund after such deposit equals the Rebate Amount. If the amount in the Rebate Fund exceeds the Rebate Amount, the Issuer may withdraw such excess amount provided that such withdrawal can be made from amounts originally transferred to the Rebate Fund and not from earnings thereon, which may not be transferred, and only if such withdrawal may be made without liquidating investments at a loss.

#### Section 3.5 Rebate Requirements and the Bond Fund

It is expected that the Bond Fund described in the Resolution and Section 2.6(c) of this Certificate will be treated as a bona fide debt service fund as defined in Regulation 1.148-1(b). As such, any amount earned during a Bond Year on the Bond Fund and amounts earned on such amounts, if allocated to the Bond Fund, will not be taken into account in calculating the Rebate Amount for the reasons outlined in Section 2.6(c) hereof. However, should the Bond Fund cease to be treated as a bona fide debt service fund, the Bond Fund will become subject to the rebate requirements set forth in Section 3.4 hereof.

#### Section 3.6 Investment of the Rebate Fund

(a) Immediately upon a transfer to the Rebate Fund, the Issuer may invest all amounts in the Rebate Fund not already invested and held in the Rebate Fund, to the extent possible, in (1) SLGS, such investments to be made at a yield of not more than one-eighth of one percent above the Bond Yield, (2) Tax Exempt Obligations, (3) direct obligations of the United States or (4) certificates of deposit of any bank or savings and loan association. All investments in the Rebate Fund shall be made to mature not later than the next Rebate Payment Date.

(b) If the Issuer invests in SLGS, the Issuer shall file timely subscription forms for such securities (if required). To the extent possible, amounts received from maturing SLGS shall be reinvested immediately in zero yield SLGS maturing on or before the next Rebate Payment Date.

#### Section 3.7 Payment to the United States

(a) On each Rebate Payment Date, the Issuer will pay to the United States at least ninety percent (90%) of the Rebate Amount less a computation credit of \$1,000 per Bond Year for which the payment is made.

(b) The Issuer will pay to the United States not later than sixty (60) days after the Final Bond Retirement Date all the rebatable arbitrage as of such date and any income attributable to such rebatable arbitrage as described in Regulation 1.148-3(f)(2).

(c) If necessary, on each Rebate Payment Date, the Issuer will mail a check to the Internal Revenue Service Center, Ogden, UT 84201. Each payment shall be accompanied by a copy of Form 8038-T, Arbitrage Rebate, filed with respect to the Bonds or other information reporting form as is required to comply with the Code and applicable Regulations.

### Section 3.8 Records

(a) The Issuer will keep and retain adequate records with respect to the Bonds, the Gross Proceeds Funds, the Bond Fund, and the Rebate Fund until six years after the Final Bond Retirement Date. Such records shall include descriptions of all calculations of amounts transferred to the Rebate Fund, if any, and descriptions of all calculations of amounts paid to the United States as required by this Certificate. Such records will also show all amounts earned on moneys invested in such funds, and the actual dates and amounts of all principal, interest and redemption premiums (if any) paid on the Bonds.

(b) Records relating to the investments in such Funds shall completely describe all transfers, deposits, disbursements and earnings including:

(1) a complete list of all investments and reinvestments of amounts in each such Fund including, if applicable, purchase price, purchase date, type of security, accrued interest paid, interest rate, dated date, principal amount, date of maturity, interest payment dates, date of liquidation, receipt upon liquidation, market value of such investment on the Final Bond Retirement Date if held by the Issuer on the Final Bond Retirement Date, and market value of the investment on the date pledged to the payment of the Bonds or the Closing Date if different from the purchase date.

(2) the amount and source of each payment to, and the amount, purpose and payee of each payment from, each such Fund.

### Section 3.9 Additional Payments

The Issuer hereby agrees to pay to the United States from legally available money of the Issuer (whether or not such available money is on deposit in any fund or account related to the Bonds) any amount which is required to be paid to the United States, but which is not available in a fund related to the Bonds for transfer to the Rebate Fund or payment to the United States.

## ARTICLE IV

### INVESTMENT RESTRICTIONS

#### Section 4.1 Avoidance of Prohibited Payments

The Issuer will not enter into any transaction that reduces the amount required to be deposited into the Rebate Fund or paid to the United States because such transaction results in a smaller profit or a larger loss than would have resulted if the transaction had been at arm's length and had the Bond Yield not been relevant to either party. The Issuer will not invest or direct the investment of any funds in a manner which reduces an amount required to be paid to the United States because such transaction results in a small profit or larger loss than would have resulted if the transaction had been at arm's length and had the Bond Yield not been relevant to the Issuer. In particular, notwithstanding anything to the contrary contained herein or in the Resolution, the Issuer will not invest or direct the investment of any funds in a manner which would violate any provision of this Article IV.

#### Section 4.2 Market Price Requirement

(a) The Issuer will not purchase or direct the purchase of Taxable Obligations for more than the then available market price for such Taxable Obligations. The Issuer will not sell, liquidate or direct the sale or liquidation of Taxable Obligations for less than the then available market price.

(b) For purposes of this Certificate, United States Treasury obligations purchased directly from the United States Treasury will be deemed to be purchased at the market price.

#### Section 4.3 Investment in Certificates of Deposit

(a) Notwithstanding anything to the contrary contained herein or in the Resolution, the Issuer will invest or direct the investment of funds on deposit in the Reserve Fund, any other Gross Proceeds Fund, the Bond Fund, and the Rebate Fund, in a certificate of deposit of a bank or savings bank which is permitted by law and by the Resolution only if the purchase price of such a certificate of deposit is treated as its fair market value on the purchase date and if the yield on the certificate of deposit is not less than (1) the yield on reasonably comparable direct obligations of the United States; and (2) the highest yield that is published or posted by the provider to be currently available from the provider on reasonably comparable certificates of deposit offered to the public.

(b) The certificate of deposit described in paragraph 4.3(a) above must be executed by a dealer who maintains an active secondary market in comparable certificates of deposit and must be based on actual trades adjusted to reflect the size and term of that certificate of deposit and the stability and reputation of the bank or savings bank issuing the certificate of deposit.

#### Section 4.4 Investment Pursuant to Investment Contracts and Agreements

The Issuer will invest or direct the investment of funds on deposit in the Gross Proceeds Funds, the Bond Fund, and the Rebate Fund pursuant to an investment contract (including a repurchase agreement) only if all of the following requirements are satisfied:

(a) The Issuer makes a bona fide solicitation for the purchase of the investment. A bona fide solicitation is a solicitation that satisfies all of the following requirements:

(1) The bid specifications are in writing and are timely forwarded to potential providers.

(2) The bid specifications include all material terms of the bid. A term is material if it may directly or indirectly affect the yield or the cost of the investment.

(3) The bid specifications include a statement notifying potential providers that submission of a bid is a representation that the potential provider did not consult with any other potential provider about its bid, that the bid was determined without regard to any other formal or informal agreement that the potential provider has with the issuer or any other person (whether or not in connection with the Bonds), and that the bid is not being submitted solely as a courtesy to the issuer or any other person for purposes of satisfying the requirements of paragraph (d)(6)(iii)(B)(1) or (2) of Section 1.148-5 of the Regulations.

(4) The terms of the bid specifications are commercially reasonable. A term is commercially reasonable if there is a legitimate business purpose for the term other than to increase the purchase price or reduce the yield of the investment.

(5) For purchases of guaranteed investment contracts only, the terms of the solicitation take into account the Issuer's reasonably expected deposit and drawdown schedule for the amounts to be invested.

(6) All potential providers have an equal opportunity to bid and no potential provider is given the opportunity to review other bids (i.e., a last look) before providing a bid.

(7) At least three reasonably competitive providers are solicited for bids. A reasonably competitive provider is a provider that has an established industry reputation as a competitive provider of the type of investments being purchased.

(b) The bids received by the Issuer meet all of the following requirements:

(1) The Issuer receives at least three bids from providers that the Issuer solicited under a bona fide solicitation meeting the requirements of paragraph (d)(6)(iii)(A) of Section 1.148-5 of the Regulations and that do not have a material financial interest in the issue. A lead underwriter in a negotiated underwriting transaction is deemed to have a material financial interest in the issue until 15 days after the issue date of the issue. In addition, any entity acting as a financial advisor with respect to the purchase of the investment at the time the bid specifications are forwarded to potential providers has a material financial interest in the issue. A provider that is a related party to a provider that has a material financial interest in the issue is deemed to have a material financial interest in the issue.

(2) At least one of the three bids described in paragraph (d)(6)(iii)(B)(1) of Section 1.148-5 of the Regulations is from a reasonably competitive provider, within the meaning of paragraph (d)(6)(iii)(A)(7) of Section 1.148-5 of the Regulations.

(3) If the Issuer uses an agent to conduct the bidding process, the agent did not bid to provide the investment.

(c) The winning bid meets the following requirements:

(1) Guaranteed investment contracts. If the investment is a guaranteed investment contract, the winning bid is the highest yielding bona fide bid (determined net of any broker's fees).

(2) Other investments. If the investment is not a guaranteed investment contract, the winning bid is the lowest cost bona fide bid (including any broker's fees).

(d) The provider of the investments or the obligor on the guaranteed investment contract certifies the administrative costs that it pays (or expects to pay, if any) to third parties in connection with supplying the investment.

(e) The Issuer will retain the following records with the bond documents until three years after the last outstanding bond is redeemed:

(1) For purchases of guaranteed investment contracts, a copy of the contract, and for purchases of investments other than guaranteed investment contracts, the purchase agreement or confirmation.

(2) The receipt or other record of the amount actually paid by the Issuer for the investments, including a record of any administrative costs paid by the Issuer, and the certification under paragraph (d)(6)(iii)(D) of Section 1.148-5 of the Regulations.

(3) For each bid that is submitted, the name of the person and entity submitting the bid, the time and date of the bid, and the bid results.

(4) The bid solicitation form and, if the terms of the purchase agreement or the guaranteed investment contract deviated from the bid solicitation form or a submitted bid is modified, a brief statement explaining the deviation and stating the purpose for the deviation.

(5) For purchases of investments other than guaranteed investment contracts, the cost of the most efficient portfolio of State and Local Government Series Securities, determined at the time that the bids were required to be submitted pursuant to the terms of the bid specifications.

#### Section 4.5 Records

The Issuer will maintain records of all purchases, sales, liquidations, investments, reinvestments, redemptions, disbursements, deposits, and transfers of amounts on deposit.

#### Section 4.6 Investments to be Legal

All investments required to be made pursuant to this Certificate shall be made to the extent permitted by law. In the event that any such investment is determined to be ultra vires, it shall be liquidated and the proceeds thereof shall be invested in a legal investment, provided that prior to reinvesting such proceeds, the Issuer shall obtain an opinion of Bond Counsel to the effect that such reinvestment will not cause the Bonds to become arbitrage bonds under Sections 103, 148, 149, or any other applicable provision of the Code.

### ARTICLE V

#### GENERAL COVENANTS

The Issuer hereby covenants to perform all acts within its power necessary to ensure that the reasonable expectations set forth in Article II hereof will be realized. The Issuer reasonably expects to comply with all covenants contained in this Certificate.

### ARTICLE VI

#### AMENDMENTS AND ADDITIONAL AGREEMENTS

#### Section 6.1 Opinion of Bond Counsel; Amendments

The various provisions of this Certificate need not be observed and this Certificate may be amended or supplemented at any time by the Issuer if the Issuer receives an opinion or opinions of Bond Counsel that the failure to comply with such provisions will not cause any of the Bonds to become "arbitrage bonds" under the Code and that the terms of such amendment or supplement will not cause any of the Bonds to become "arbitrage bonds" under the Code, or otherwise cause interest on any of the Bonds to become includable in gross income for federal income tax purposes.

Section 6.2 Additional Covenants, Agreements

The Issuer hereby covenants to make, execute and enter into (and to take such actions, if any, as may be necessary to enable it to do so) such agreements as may be necessary to comply with any changes in law or regulations in order to preserve the tax-exempt status of the Bonds to the extent that it may lawfully do so. The Issuer further covenants (1) to impose such limitations on the investment or use of moneys or investments related to the Bonds, (2) to make such payments to the United States Treasury, (3) to maintain such records, (4) to perform such calculations, and (5) to perform such other lawful acts as may be necessary to preserve the tax-exempt status of the Bonds.

Section 6.3 Internal Revenue Service Audits

The Internal Revenue Service has not audited the Issuer regarding any obligations issued by or on behalf of the Issuer. To the best knowledge of the Issuer, no such obligations of the Issuer are currently under examination by the Internal Revenue Service.

Section 6.4 Amendments

Except as otherwise provided in Section 6.1 hereof, all the rights, powers, duties and obligations of the Issuer shall be irrevocable and binding upon the Issuer and shall not be subject to amendment or modification by the Issuer.

IN WITNESS WHEREOF, the Issuer has caused this Certificate to be executed by its duly authorized officer, all as of the day first above written.

\_\_\_\_\_  
Finance Director, City of Bettendorf, State of  
Iowa

(SEAL)

EXHIBIT "A"

**\$19,745,000 GENERAL OBLIGATION BONDS, SERIES 2026A**

**ISSUE PRICE CERTIFICATE**

The undersigned, on behalf of Piper Sandler & Co. ("Purchaser"), hereby certifies as set forth below with respect to the sale of the above-captioned obligations (the "Bonds").

1. Reasonably Expected Initial Offering Price.

a) As of the Sale Date, the reasonably expected initial offering prices of the Bonds to the Public by Purchaser are the prices listed in Schedule A (the "Expected Offering Prices"). The Expected Offering Prices are the prices for the Maturities of the Bonds used by Purchaser in formulating its bid to purchase the Bonds. Attached as Schedule B is a true and correct copy of the bid provided by Purchaser to purchase the Bonds.

b) Purchaser was not given the opportunity to review other bids prior to submitting its bid.

c) The bid submitted by Purchaser constituted a firm offer to purchase the Bonds.

2. ***Defined Terms.***

a) *Maturity* means Bonds with the same credit and payment terms. Bonds with different maturity dates, or Bonds with the same maturity date but different stated interest rates, are treated as separate Maturities.

b) *Public* means any person (including an individual, trust, estate, partnership, association, company, or corporation) other than an Underwriter or a related party to an Underwriter. The term "related party" for purposes of this certificate generally means any two or more persons who have greater than 50 percent common ownership, directly or indirectly.

c) *Sale Date* means the first day on which there is a binding contract in writing for the sale of a Maturity of the Bonds. The Sale Date of the Bonds is February 17, 2026.

d) *Underwriter* means (i) the Purchaser or any person that agrees pursuant to a written contract with the Issuer (or with the lead underwriter to form an underwriting syndicate) to participate in the initial sale of the Bonds to the Public, and (ii) any person that agrees pursuant to a written contract directly or indirectly with a person described in clause (i) of this paragraph to participate in the initial sale of the Bonds to the Public (including a member of a selling group or a party to a retail distribution agreement participating in the initial sale of the Bonds to the Public).

The representations set forth in this certificate are limited to factual matters only. Nothing in this certificate represents Purchaser's interpretation of any laws, including specifically Sections 103 and 148 of the Internal Revenue Code of 1986, as amended, and the Treasury Regulations thereunder. The undersigned understands that the foregoing information

will be relied upon by the Issuer with respect to certain of the representations set forth in the Tax Exemption Certificate and with respect to compliance with the federal income tax rules affecting the Bonds, and by Ahlers & Cooney, P.C. in connection with rendering its opinion that the interest on the Bonds is excluded from gross income for federal income tax purposes, the preparation of the Internal Revenue Service Form 8038-G, and other federal income tax advice that it may give to the Issuer from time to time relating to the Bonds.

PIPER SANDLER & CO.

By: \_\_\_\_\_

Name: \_\_\_\_\_

Dated: March 26, 2026

**SCHEDULE A**  
**EXPECTED OFFERING PRICES**

*(Attached)*

**SCHEDULE B**

**COPY OF UNDERWRITER'S BID**

*(Attached)*

## **\$19,745,000 GENERAL OBLIGATION BONDS, SERIES 2026A**

### **CERTIFICATE OF MUNICIPAL ADVISOR**

The undersigned, on behalf of Baker Tilly Municipal Advisors, LLC (the "Municipal Advisor"), as the municipal advisor to the City of Bettendorf, Iowa ("Issuer") in connection with the issuance of the above-captioned obligations (the "Bonds"), has assisted the Issuer in soliciting and receiving bids from potential underwriters in connection with the sale of the Bonds in a competitive bidding process in which bids were requested for the purchase of the Bonds at specified written terms, and hereby certifies as set forth below with respect to the bidding process and award of the Bonds.

1. The Bonds were offered for sale at specified written terms more particularly described in the Notice of Sale, which was distributed to potential bidders, a copy of which is attached to this certificate as Attachment 1.

2. The Official Terms of Offering and preliminary official statements are distributed to the leading aggregators of municipal new issuance sale information, such as IPREO, Bloomberg, CUSIP Global Services, nationally recognized bond insurance companies and broker dealers, banks or portfolio buyers with a history of bidding publicly offered debt. In addition, all offering documents are posted to the Municipal Advisor's public website which can be accessed at <https://bondcalendar.bakertilly.com>. Interested bidders may submit a bid via the IPREO Parity electronic bid submission system, by email, by fax, or by telephone provided a bid form is confirmed by the bidder prior to the time established for opening of bids. Bidding instructions are contained within the Official Terms of Offering. The method of distribution of the Official Terms of Offering is regularly used for purposes of disseminating notice of competitive sale of new issuances of municipal bonds, and notices disseminated in such manner are widely available to potential bidders. Notification of the sale was also disseminated to Bloomberg, the Bond Buyer, and MuniPlatform who each publish lists of upcoming competitive sales that are available to potential bidders. The Municipal Advisor notifies the winning bidder(s) after the sale has been conducted.

3. To the knowledge of the Municipal Advisor, all bidders were offered an equal opportunity to bid to purchase the Bonds so that, for example, if the bidding process afforded any opportunity for bidders to review other bids before providing a bid, no bidder was given an opportunity to review other bids that was not equally given to all other bidders (that is, no exclusive "last-look").

4. The Issuer received bids from at least three bidders who represented that they have established industry reputations for underwriting new issuances of municipal bonds. Based upon the Municipal Advisor's knowledge and experience in acting as the municipal advisor for other municipal issues, the Municipal Advisor believes those representations to be accurate. Copies of the bids received are attached to this certificate as Attachment 2.

5. The winning bidder was Piper Sandler & Co. (the "Purchaser"), whose bid was determined to be the best conforming bid in accordance with the terms set forth in the Notice of

Sale, as shown in the bid comparison attached as Attachment 3 to this certificate. The Issuer awarded the Bonds to the Purchaser.

The representations set forth in this certificate are limited to factual matters only. Nothing in this certificate represents the Municipal Advisor's interpretation of any laws, including specifically Sections 103 and 148 of the Internal Revenue Code of 1986, as amended, and the Treasury Regulations thereunder. The undersigned understands that the foregoing information will be relied upon by the Issuer with respect to certain of the representations set forth in the Tax Exemption Certificate and with respect to compliance with the federal income tax rules affecting the Bonds, and by Ahlers & Cooney, P.C. in connection with rendering its opinion that the interest on the Bonds is excluded from gross income for federal income tax purposes, the preparation of the Internal Revenue Service Form 8038-G, and other federal income tax advice that it may give to the Issuer from time to time relating to the Bonds. No other persons may rely on the representations set forth in this certificate without the prior written consent of the Municipal Advisor.

BAKER TILLY MUNICIPAL ADVISORS,  
LLC

By: \_\_\_\_\_

Name: \_\_\_\_\_

Dated: March 26, 2026

**ATTACHMENT 1**  
**OFFICIAL TERMS OF OFFERING**

*(Attached)*

**ATTACHMENT 2**

**BIDS RECEIVED**

*(Attached)*

**ATTACHMENT 3**  
**BID COMPARISON**

*(Attached)*

EXHIBIT "B"

CONSTRUCTION ISSUE CERTIFICATION

I, the undersigned, do hereby certify that I am the Finance Director of the City of Bettendorf, Iowa. I acknowledge that this Certificate is given as the basis for certain representations made in the Tax Exemption Certificate delivered by the City of Bettendorf, State of Iowa (the "Issuer"), as of the date hereof, in connection with the issuance of \$19,745,000 General Obligation Bonds, Series 2026A, of the Issuer (the "Bonds").

The Issuer has elected to satisfy the requirements of Code Section 148(f)(4)(C)(iv)(I) based upon its reasonable expectations that more than 75% of the "available construction proceeds" of the Bonds, as defined in Section 148(f)(4)(C)(vi) of the Code, are to be used for construction expenditures with respect to property to be owned by the Issuer as a governmental unit.

Construction expenditures means capital expenditures, as defined in Regulation 1.150-1(b), that, on or before the date the property financed by the expenditures is placed in service, as defined in Regulation 1.150-2(c), will be properly chargeable to or may be capitalized as part of the basis of (1) real property, other than expenditures for the acquisition of any interest in land or real property other than land, (2) constructed personal property as defined in Regulation 1.148-7(g)(3), or (3) specially developed computer software as defined in Regulation 1.148-7(g)(4), that is functionally related and subordinate to real property or constructed personal property.

As of the date of issue of the Bonds, it is my opinion that at least 75% of the available construction proceeds of the Issue will be used for construction expenditures as defined above.

IN WITNESS WHEREOF, I hereunto affix my official signature this 26<sup>th</sup> day of March, 2026.

BETTENDORF, IOWA

By: \_\_\_\_\_

Title: Finance Director

## CONTINUING DISCLOSURE CERTIFICATE

This Continuing Disclosure Certificate (the "Disclosure Certificate") is executed and delivered by the City of Bettendorf, State of Iowa (the "Issuer"), in connection with the issuance of \$19,745,000 General Obligation Bonds, Series 2026A (the "Bonds") dated March 26, 2026. The Bonds are being issued pursuant to a Resolution of the Issuer approved on March 3, 2026 (the "Resolution"). The Issuer covenants and agrees as follows:

Section 1. Purpose of the Disclosure Certificate; Interpretation. This Disclosure Certificate is being executed and delivered by the Issuer for the benefit of the Holders and Beneficial Owners of the Bonds and in order to assist the Participating Underwriters in complying with S.E.C. Rule 15c2-12(b)(5). This Disclosure Certificate shall be governed by, construed and interpreted in accordance with the Rule, and, to the extent not in conflict with the Rule, the laws of the State. Nothing herein shall be interpreted to require more than required by the Rule.

Section 2. Definitions. In addition to the definitions set forth in the Resolution, which apply to any capitalized term used in this Disclosure Certificate unless otherwise defined in this Section, the following capitalized terms shall have the following meanings:

"Annual Financial Information" shall mean financial information or operating data of the type included in the final Official Statement, provided at least annually by the Issuer pursuant to, and as described in, Sections 3 and 4 of this Disclosure Certificate.

"Beneficial Owner" shall mean any person which (a) has the power, directly or indirectly, to vote or consent with respect to, or to dispose of ownership of, any Bonds (including persons holding Bonds through nominees, depositories or other intermediaries), or (b) is treated as the owner of any Bonds for federal income tax purposes.

"Business Day" shall mean a day other than a Saturday or a Sunday or a day on which banks in Iowa are authorized or required by law to close.

"Dissemination Agent" shall mean the Issuer or any Dissemination Agent designated in writing by the Issuer and which has filed with the Issuer a written acceptance of such designation.

"Financial Obligation" shall mean a (i) debt obligation; (ii) derivative instrument entered into in connection with, or pledged as security or a source of payment for, an existing or planned debt obligation; or (iii) guarantee of (i) or (ii). The term Financial Obligation shall not include municipal securities as to which a final official statement has been provided to the MSRB consistent with S.E.C. Rule 15c2-12.

"Holders" shall mean the registered holders of the Bonds, as recorded in the registration books of the Registrar.

"Listed Events" shall mean any of the events listed in Section 5(a) of this Disclosure Certificate.

"Municipal Securities Rulemaking Board" or "MSRB" shall mean the Municipal Securities Rulemaking Board, 1300 I Street NW, Suite 1000, Washington, DC 20005.

"National Repository" shall mean the MSRB's Electronic Municipal Market Access website, a/k/a "EMMA" (emma.msrb.org).

"Official Statement" shall mean the Issuer's Official Statement for the Bonds, dated February 17, 2026.

"Participating Underwriter" shall mean any of the original underwriters of the Bonds required to comply with the Rule in connection with offering of the Bonds.

"Rule" shall mean Rule 15c2-12 adopted by the Securities and Exchange Commission (S.E.C.) under the Securities Exchange Act of 1934, and any guidance and procedures thereunder published by the S.E.C., as the same may be amended from time to time.

"State" shall mean the State of Iowa.

### Section 3. Provision of Annual Financial Information.

a) The Issuer shall, or shall cause the Dissemination Agent to, not later than three hundred sixty-five (365) days after the end of the Issuer's fiscal year (presently June 30th), commencing with information for the 2025/2026 fiscal year, provide to the National Repository an Annual Financial Information filing consistent with the requirements of Section 4 of this Disclosure Certificate. The Annual Financial Information filing must be submitted in such format as is required by the MSRB (currently in "searchable PDF" format). The Annual Financial Information filing may be submitted as a single document or as separate documents comprising a package. The Annual Financial Information filing may cross-reference other information as provided in Section 4 of this Disclosure Certificate; provided that the audited financial statements of the Issuer may be submitted separately from the balance of the Annual Financial Information filing and later than the date required above for the filing of the Annual Financial Information if they are not available by that date. If the Issuer's fiscal year changes, it shall give notice of such change in the same manner as for a Listed Event under Section 5(c).

b) If the Issuer is unable to provide to the National Repository the Annual Financial Information by the date required in subsection (a), the Issuer shall send a notice to the Municipal Securities Rulemaking Board, if any, in substantially the form attached as Exhibit A.

c) The Dissemination Agent shall:

i. each year file Annual Financial Information with the National Repository; and

ii. (if the Dissemination Agent is other than the Issuer), file a report with the Issuer certifying that the Annual Financial Information has been filed pursuant to this Disclosure Certificate, stating the date it was filed.

Section 4. Content of Annual Financial Information. The Issuer's Annual Financial Information filing shall contain or incorporate by reference the following:

a) The last available audited financial statements of the Issuer for the prior fiscal year, prepared in accordance with generally accepted accounting principles promulgated by the Financial Accounting Standards Board as modified in accordance with the governmental accounting standards promulgated by the Governmental Accounting Standards Board or as otherwise provided under State law, as in effect from time to time, or, if and to the extent such financial statements have not been prepared in accordance with generally accepted accounting principles, noting the discrepancies therefrom and the effect thereof. If the Issuer's audited financial statements for the preceding years are not available by the time Annual Financial Information is required to be filed pursuant to Section 3(a), the Annual Financial Information filing shall contain unaudited financial statements of the type included in the final Official Statement, and the audited financial statements shall be filed in the same manner as the Annual Financial Information when they become available.

b) A table, schedule or other information prepared as of the end of the preceding fiscal year, of the type contained in the final Official Statement under the caption:

- i. City Property Values;
- ii. City Indebtedness;
- iii. City Tax Rates, Levies and Collections; and
- iv. Funds on Hand.

Any or all of the items listed above may be included by specific reference to other documents, including official statements of debt issues of the Issuer or related public entities, which have been filed with the National Repository. The Issuer shall clearly identify each such other document so included by reference.

Section 5. Reporting of Significant Events.

a) Pursuant to the provisions of this Section, the Issuer shall give, or cause to be given, notice of the occurrence of any of the following events with respect to the Bonds in a timely manner not later than 10 Business Days after the day of the occurrence of the event:

- i. Principal and interest payment delinquencies;
- ii. Non-payment related defaults, if material;
- iii. Unscheduled draws on debt service reserves reflecting financial difficulties;

iv. Unscheduled draws on credit enhancements relating to the Bonds reflecting financial difficulties;

v. Substitution of credit or liquidity providers, or their failure to perform;

vi. Adverse tax opinions, the issuance by the Internal Revenue Service of proposed or final determinations of taxability, Notices of Proposed Issue (IRS Form 5701-TEB) or other material notices or determinations with respect to the tax-exempt status of the Series Bonds, or material events affecting the tax-exempt status of the Bonds;

vii. Modifications to rights of Holders of the Bonds, if material;

viii. Bond calls (excluding sinking fund mandatory redemptions), if material, and tender offers;

ix. Defeasances of the Bonds;

x. Release, substitution, or sale of property securing repayment of the Bonds, if material;

xi. Rating changes on the Bonds;

xii. Bankruptcy, insolvency, receivership or similar event of the Issuer;

xiii. The consummation of a merger, consolidation, or acquisition involving the Issuer or the sale of all or substantially all of the assets of the Issuer, other than in the ordinary course of business, the entry into a definitive agreement to undertake such an action or the termination of a definitive agreement relating to any such actions, other than pursuant to its terms, if material;

xiv. Appointment of a successor or additional trustee or the change of name of a trustee, if material;

xv. Incurrence of a Financial Obligation of the Issuer, if material, or agreement to covenants, events of default, remedies, priority rights, or other similar terms of a Financial Obligation of the Issuer, any of which affect security holders, if material; and

xvi. Default, event of acceleration, termination event, modification of terms or other similar events under the terms of a Financial Obligation of the Issuer, any of which reflect financial difficulties.

b) Whenever the Issuer obtains the knowledge of the occurrence of a Listed Event, the Issuer shall determine if the occurrence is subject to notice only if material, and if so shall as soon as possible determine if such event would be material under applicable federal securities laws.

c) If the Issuer determines that knowledge of the occurrence of a Listed Event is not subject to materiality, or determines such occurrence is subject to materiality and would be material under applicable federal securities laws, the Issuer shall promptly, but not later than 10 Business Days after the occurrence of the event, file a notice of such occurrence with the Municipal Securities Rulemaking Board through the filing with the National Repository.

Section 6. Termination of Reporting Obligation. The Issuer's obligations under this Disclosure Certificate with respect to each Series of Bonds shall terminate upon the legal defeasance, prior redemption or payment in full of all of the Bonds of that Series or upon the Issuer's receipt of an opinion of nationally recognized bond counsel to the effect that, because of legislative action or final judicial action or administrative actions or proceedings, the failure of the Issuer to comply with the terms hereof will not cause Participating Underwriters to be in violation of the Rule or other applicable requirements of the Securities Exchange Act of 1934, as amended.

Section 7. Dissemination Agent. The Issuer may, from time to time, appoint or engage a Dissemination Agent to assist it in carrying out its obligations under this Disclosure Certificate, and may discharge any such Agent, with or without appointing a successor Dissemination Agent. The Dissemination Agent shall not be responsible in any manner for the content of any notice or report prepared by the Issuer pursuant to this Disclosure Certificate. The initial Dissemination Agent shall be the Issuer.

Section 8. Amendment; Waiver. Notwithstanding any other provision of this Disclosure Certificate, the Issuer may amend this Disclosure Certificate, and any provision of this Disclosure Certificate may be waived, provided that the following conditions are satisfied:

- a) If the amendment or waiver relates to the provisions of Section 3(a), 4, or 5(a), it may only be made in connection with a change in circumstances that arises from a change in legal requirements, change in law, or change in the identity, nature or status of an obligated person with respect to the Bonds, or the type of business conducted;
- b) The undertaking, as amended or taking into account such waiver, would, in the opinion of nationally recognized bond counsel, have complied with the requirements of the Rule at the time of the original issuance of the Bonds, after taking into account any amendments or interpretations of the Rule, as well as any change in circumstances; and
- c) The amendment or waiver either (i) is approved by the Holders of the Bonds in the same manner as provided in the Resolution for amendments to the Resolution with the consent of Holders, or (ii) does not, in the opinion of nationally recognized bond counsel, materially impair the interests of the Holders or Beneficial Owners of the Bonds.

In the event of any amendment or waiver of a provision of this Disclosure Certificate, the Issuer shall describe such amendment in the next Annual Financial Information filing, and shall include, as applicable, a narrative explanation of the reason for the amendment or waiver and its impact on the type (or in the case of a change of accounting principles, on the presentation) of financial information or operating data being presented by the Issuer. In addition, if the

amendment relates to the accounting principles to be followed in preparing financial statements, (i) notice of such change shall be given in the same manner as for a Listed Event under Section 5(c), and (ii) the Annual Financial Information filing for the year in which the change is made will present a comparison or other discussion in narrative form (and also, if feasible, in quantitative form) describing or illustrating the material differences between the financial statements as prepared on the basis of the new accounting principles and those prepared on the basis of the former accounting principles.

Section 9. Additional Information. Nothing in this Disclosure Certificate shall be deemed to prevent the Issuer from disseminating any other information, using the means of dissemination set forth in this Disclosure Certificate or any other means of communication, or including any other information in any Annual Financial Information filing or notice of occurrence of a Listed Event, in addition to that which is required by this Disclosure Certificate. If the Issuer chooses to include any information in any Annual Financial Information filing or notice of occurrence of a Listed Event in addition to that which is specifically required by this Disclosure Certificate, the Issuer shall have no obligation under this Certificate to update such information or include it in any future Annual Financial Information filing or notice of occurrence of a Listed Event.

Section 10. Default. In the event of a failure of the Issuer to comply with any provision of this Disclosure Certificate, any Holder or Beneficial Owner of the Bonds may take such actions as may be necessary and appropriate, including seeking mandate or specific performance by court order, to cause the Issuer to comply with its obligations under this Disclosure Certificate. Direct, indirect, consequential and punitive damages shall not be recoverable by any person for any default hereunder and are hereby waived to the extent permitted by law. A default under this Disclosure Certificate shall not be deemed an event of default under the Resolution, and the sole remedy under this Disclosure Certificate in the event of any failure of the Issuer to comply with this Disclosure Certificate shall be an action to compel performance.

Section 11. Duties, Immunities and Liabilities of Dissemination Agent. The Dissemination Agent shall have only such duties as are specifically set forth in this Disclosure Certificate, and the Issuer agrees to indemnify and save the Dissemination Agent, its officers, directors, employees and agents, harmless against any loss, expense and liabilities which it may incur arising out of or in the exercise or performance of its powers and duties hereunder, including the costs and expenses (including attorneys' fees) of defending against any claim of liability, but excluding liabilities due to the Dissemination Agent's negligence or willful misconduct. The obligations of the Issuer under this Section shall survive resignation or removal of the Dissemination Agent and payment of the Bonds.

Section 12. Beneficiaries. This Disclosure Certificate shall inure solely to the benefit of the Issuer, the Dissemination Agent, the Participating Underwriters and Holders and Beneficial Owners from time to time of the Bonds, and shall create no rights in any other person or entity.

Section 13. Rescission Rights. The Issuer hereby reserves the right to rescind this Disclosure Certificate without the consent of the Holders in the event the Rule is repealed by the S.E.C. or is ruled invalid by a federal court and the time to appeal from such decision has expired. In the event of a partial repeal or invalidation of the Rule, the Issuer hereby reserves the

right to rescind those provisions of this Disclosure Certificate that were required by those parts of the Rule that are so repealed or invalidated.

Date: 26<sup>th</sup> day of March, 2026.

CITY OF BETTENDORF, STATE OF IOWA

By: \_\_\_\_\_  
Mayor

ATTEST:

By: \_\_\_\_\_  
City Clerk

EXHIBIT A

NOTICE TO NATIONAL REPOSITORY OF FAILURE TO FILE ANNUAL FINANCIAL INFORMATION

Name of Issuer: City of Bettendorf, Iowa.

Name of Bond Issue: \$19,745,000 General Obligation Bonds, Series 2026A

Dated Date of Issue: March 26, 2026

NOTICE IS HEREBY GIVEN that the Issuer has not provided Annual Financial Information with respect to the above-named Bonds as required by Section 3 of the Continuing Disclosure Certificate delivered by the Issuer in connection with the Bonds. The Issuer anticipates that the Annual Financial Information will be filed by \_\_\_\_\_.

Dated: \_\_\_\_\_ day of \_\_\_\_\_, 20\_\_.

CITY OF BETTENDORF, STATE OF IOWA

By: \_\_\_\_\_  
Its: \_\_\_\_\_

DELIVERY CERTIFICATE

We the undersigned City Officials, do hereby certify that we are the officers, respectively below indicated, of a municipal corporation in the State of Iowa, known as the City of Bettendorf, State of Iowa; that in pursuance of the provisions of Sections 384.25, 384.26, 384.28 and 403.12, Code of Iowa, there have been heretofore lawfully authorized and this day by us lawfully executed, issued, caused to be registered, authenticated and delivered fully registered General Obligation Bonds, Series 2026A, of the City of Bettendorf, State of Iowa, in the amount of \$19,745,000, dated March 26, 2026, bearing interest and maturing as follows:

<u>Principal Amount</u>	<u>Interest Rate</u>	<u>Maturity June 1<sup>st</sup></u>
\$ 640,000	5.000%	2027
\$ 840,000	5.000%	2028
\$ 880,000	5.000%	2029
\$ 930,000	5.000%	2030
\$ 975,000	5.000%	2031
\$1,025,000	5.000%	2032
\$1,075,000	5.000%	2033
\$1,125,000	5.000%	2034
\$1,180,000	5.000%	2035
\$1,240,000	5.000%	2036
\$1,300,000	5.000%	2037
\$1,370,000	5.000%	2038
\$1,435,000	5.000%	2039
\$1,510,000	5.000%	2040
\$ 780,000	4.000%	2041
\$ 810,000	4.000%	2042
\$2,630,000	4.000%	2045*

\*Term Bonds

Each of the Bonds has been executed with the manual or facsimile signature of the Mayor and the manual or facsimile signature of the City Clerk of the City.

The Bonds have been delivered to DTC on behalf of:

Piper Sandler & Co. of Minneapolis, Minnesota

and have been paid for in accordance with the terms of the contract of sale and at a price of \$22,051,268.74, and accrued interest.

We further certify that no controversy or litigation is pending, prayed or threatened involving the incorporation, organization, existence or boundaries of the City, or the titles of the undersigned City officers to their respective positions, or the validity of the Bonds, or the power

and duty of the City to provide and apply adequate taxes for the full and prompt payment of the principal and interest of the Bonds, and that no measure or provision for the authorization or issuance of the Bonds has been repealed or rescinded.

We further certify that due provision has been made for the collection of sufficient taxes to meet all payments coming due, whether of principal or of interest on the Bond Issue; that all payments coming due before the next collection of the tax provided for as aforesaid will be paid promptly when due from cash on hand; and that the proceedings authorizing the issuance and delivery of the Bonds remain in full force and effect and have not been withdrawn, amended or rescinded.

To the best of our knowledge, information and belief, we further certify that the Official Statement dated February 17, 2026, as of its date and the date hereof, did not and does not contain any untrue statement of material fact or omit to state a material fact necessary in order to make the statements made therein, in light of the circumstances under which they were made, not misleading.

We further certify that each of the officers whose signatures appear on the Bonds were in occupancy and possession of their respective offices at the time the Bonds were executed and do hereby adopt and affirm their signatures appearing in the Bonds.

We further certify that the present financial condition of the Bond is as follows:

Assessed and taxable value of all taxable property within the City, except moneys and credits and tax free lands (Year 2025/2026), according to the last completed State and County tax lists (100% - Before Rollback)	\$6,041,523,928
Total general obligation bonded indebtedness of the City, <u>including this issue</u>	\$159,700,000
All other general obligation indebtedness, (including warrants, judgments, contracts of purchase or lease/purchase, self-insurance or local government risk pool obligations, loan agreements, and revenue bonds issued under Code Section 403.9), of the City of any kind	\$ _____

IN WITNESS WHEREOF, we have hereunto affixed our hands at the City of Bettendorf,  
State of Iowa, this 26<sup>th</sup> day of March, 2026.

---

Mayor

---

City Clerk

---

Finance Director

(CITY SEAL)

4924-0265-8704-1\10216-112

TRANSCRIPT CERTIFICATE

I, the undersigned, being first duly sworn, do hereby depose and certify that I am the duly appointed, qualified and acting City Clerk of the City of Bettendorf, State of Iowa, and that as such Clerk I have in my possession or have access to the complete corporate records of the City and of its Council and officials, and that I have carefully compared the transcript hereto attached with the aforesaid corporate records and that the transcript hereto attached is a true and complete copy of all the corporate records in relation to the authorization, issuance and disposition of \$19,745,000 General Obligation Bonds, Series 2026A, of the City dated March 26, 2026, and that the transcript hereto attached contains a true and complete statement of all the measures adopted and proceedings, acts and things had, done and performed up to the present time, in relation to the authorization, issuance and disposition of the Bonds, and that the City Council consists of a Mayor and seven (7) Council Members, and that the offices were duly and lawfully filled by the individuals listed in the attached transcript as of the dates and times referred to therein.

I further certify that the City is and throughout the period of such proceedings has been governed under the Mayor/Council form of municipal government authorized by Chapter 372, Code of Iowa, under the provisions of its charter as recorded with the Secretary of State.

I further certify that according to the records in my office, the named members of the Council were duly and regularly elected to such office, and were, during all of the year 2026, and now are, the legally elected, constituted and acting City Council of the City.

I further certify that no litigation is pending, prayed or threatened affecting the validity of the Bonds hereinabove referred to, nor affecting the title of any of the City officers and Council Members to their official positions.

I further certify that all meetings of the City Council of the City at which action was taken in connection with the Bonds were open to the public at all times in accordance with a notice of meeting and tentative agenda, a copy of which was timely served on each member of the Council and was duly given at least twenty-four hours prior to the commencement of the meeting by notification of the communications media having requested such notice and posted on a bulletin board or other prominent place designated for the purpose and easily accessible to the public at the principal office of the Council all pursuant to the provisions and in accordance with the conditions of the local rules of the Council and Chapter 21, Code of Iowa.

I further certify that no City officer or employee has any interest in the contract for the sale of the Bonds or any matter incidental thereto, according to my best knowledge and belief.

WITNESS my hand and the seal of the City hereto attached this \_\_\_\_\_ day of \_\_\_\_\_, 2026, at Bettendorf, Iowa.

\_\_\_\_\_  
City Clerk, City of Bettendorf, State of Iowa

(SEAL)

Finally, the below stated officers whose signatures appear hereafter are now the duly qualified and acting officials of the City, possessed of the offices as designated below, to-wit:

Mayor:

Robert S. Gallagher

\_\_\_\_\_  
(Original Signature)

Clerk:

Decker P. Ploehn

\_\_\_\_\_  
(Original Signature)

Finance Director:

Jason Schadt

\_\_\_\_\_  
(Original Signature)

STATE OF IOWA

)

) SS

COUNTY OF SCOTT

)

Subscribed and sworn to before me by Robert S. Gallagher, Decker P. Ploehn and Jason Schadt on this \_\_\_\_\_ day of \_\_\_\_\_, 2026.

\_\_\_\_\_  
Notary Public in and for Scott County, Iowa

(SEAL)

AUTHENTICATION ORDER

The undersigned Finance Director of the City of Bettendorf, State of Iowa (the "Issuer"), pursuant to a resolution of the City Council of the City of Bettendorf, authorizing the issuance and delivery of the Bonds, acting for and on behalf of the Issuer, hereby deliver to UMB Bank, N.A. (the "Registrar") \$19,745,000 aggregate principal amount of Issuer's General Obligation Bonds, Series 2026A, dated March 26, 2026 in fully registered form, bearing interest, maturing and conforming to the specifications set forth in the Resolution (the "Bonds").

Each Bond has been executed on behalf of the Issuer with the manual or facsimile signature of the Mayor and the manual or facsimile signature of the City Clerk. The signatures are hereby ratified, affirmed and adopted.

The seal of the Issuer is printed or impressed thereon.

The Registrar is hereby requested to authenticate the Bonds and to complete the records with respect to registration as provided in the Bond Resolution and the instructions of the Original Purchaser as to designation of owners of the Bonds.

Upon such authentication, the Registrar is authorized to deliver the Bonds on behalf of Issuer to the Original Purchaser, Piper Sandler & Co., or their registered assigns, upon receipt of payment therefor in immediately available funds of the agreed purchase price plus accrued interest to the date of delivery as shown on Exhibit A attached hereto and incorporated herein, subject to the receipt at closing of the opinion of bond counsel. The Original Purchaser shall deposit the monies to the account of Issuer as designated in Exhibit A.

The acknowledgment of receipt of the Bonds by the Original Purchasers, or registered assigns, shall be evidenced by separate signed receipts or certificates.

Dated: this \_\_\_\_\_ day of \_\_\_\_\_, 2026

\_\_\_\_\_  
Finance Director

(SEAL)

EXHIBIT A

Closing Amounts

Deposit of Funds Instructions

(See attached closing letter of the Financial Consultant)

COUNTY AUDITOR'S CERTIFICATE

I, \_\_\_\_\_, County Auditor of Scott County, State of Iowa, hereby certify that on the \_\_\_\_\_ day of \_\_\_\_\_, 2026 there was filed in my office the Resolution of the City Council of the City of Bettendorf, State of Iowa, adopted on the 3<sup>rd</sup> day of March, 2026, such Resolution levying a tax for the purpose of paying principal and interest on \$19,745,000 of General Obligation Bonds, Series 2026A, dated March 26, 2026, and authorizing the issuance of the Bonds.

I further certify that no petition or proceeding has been filed or commenced to contest the officially certified result of the election held November 4, 2025, for the authorization of the Bonds.

(COUNTY SEAL)

\_\_\_\_\_  
County Auditor of Scott County, State of Iowa

▶ Under Internal Revenue Code section 149(e)

▶ See separate instructions.

Caution: If the issue price is under \$100,000, use Form 8038-GC.

▶ Go to [www.irs.gov/F8038G](http://www.irs.gov/F8038G) for instructions and the latest information.

Department of the Treasury  
Internal Revenue Service

<b>Part I Reporting Authority</b>		Check box if Amended Return <input type="checkbox"/>	
1 Issuer's name <u>Bettendorf, Iowa</u>		2 Issuer's employer identification number (EIN)	
3a Name of person (other than issuer) with whom the IRS may communicate about this return (see instructions)		3b Telephone number of other person shown on 3a	
4 Number and street (or P.O. box if mail is not delivered to street address)	Room/suite	5 Report number (For IRS Use Only)	
<u>1609 State Street</u>		3	
6 City, town, or post office, state, and ZIP code <u>Bettendorf, Iowa 52722-4971</u>		7 Date of issue <u>03/26/2026</u>	
8 Name of issue <u>\$19,745,000 General Obligation Bonds, Series 2026A</u>		9 CUSIP number <u>087672 GV7</u>	
10a Name and title of officer or other employee of the issuer whom the IRS may call for more information <u>Jason Schadt, Finance Director</u>		10b Telephone number of officer or other employee shown on 10a <u>(563) 344-4116</u>	

**Part II Type of Issue (Enter the issue price.)** See the instructions and attach schedule.

11 Education	11	
12 Health and hospital	12	
13 Transportation	13	12,037,324.45
14 Public safety	14	10,078,027.15
15 Environment (including sewage bonds)	15	
16 Housing	16	
17 Utilities	17	
18 Other. Describe ▶	18	
19a If bonds are TANs or RANs, check only box 19a		<input type="checkbox"/>
b If bonds are BANs, check only box 19b		<input type="checkbox"/>
20 If bonds are in the form of a lease or installment sale, check box		<input type="checkbox"/>

**Part III Description of Bonds.** Complete for the entire issue for which this form is being filed.

	(a) Final maturity date	(b) Issue price	(c) Stated redemption price at maturity	(d) Weighted average maturity	(e) Yield
21	06/01/2045	\$ 22,115,351.60	\$ 19,745,000	10.300 years	3.054235 %

**Part IV Uses of Proceeds of Bond Issue (including underwriters' discount)**

22 Proceeds used for accrued interest	22	-0-
23 Issue price of entire issue (enter amount from line 21, column (b))	23	22,115,351.60
24 Proceeds used for bond issuance costs (including underwriters' discount)	24	168,669.86
25 Proceeds used for credit enhancement	25	-0-
26 Proceeds allocated to reasonably required reserve or replacement fund	26	-0-
27 Proceeds used to refund prior tax-exempt bonds. Complete Part V	27	-0-
28 Proceeds used to refund prior taxable bonds. Complete Part V	28	-0-
29 Total (add lines 24 through 28)	29	168,669.86
30 Nonrefunding proceeds of the issue (subtract line 29 from line 23 and enter amount here)	30	21,946,681.74

**Part V Description of Refunded Bonds.** Complete this part only for refunding bonds.

31 Enter the remaining weighted average maturity of the tax-exempt bonds to be refunded	▶	NA	years
32 Enter the remaining weighted average maturity of the taxable bonds to be refunded	▶	NA	years
33 Enter the last date on which the refunded tax-exempt bonds will be called (MM/DD/YYYY)	▶		
34 Enter the date(s) the refunded bonds were issued (MM/DD/YYYY)	▶		

**Part VI Miscellaneous**

<b>35</b>	Enter the amount of the state volume cap allocated to the issue under section 141(b)(5) . . . . .	<b>35</b>	
<b>36a</b>	Enter the amount of gross proceeds invested or to be invested in a guaranteed investment contract (GIC). See instructions . . . . .	<b>36a</b>	
<b>b</b>	Enter the final maturity date of the GIC ▶ (MM/DD/YYYY) _____		
<b>c</b>	Enter the name of the GIC provider ▶ _____		
<b>37</b>	Pooled financings: Enter the amount of the proceeds of this issue that are to be used to make loans to other governmental units . . . . .	<b>37</b>	
<b>38a</b>	If this issue is a loan made from the proceeds of another tax-exempt issue, check box <input type="checkbox"/> and enter the following information:		
<b>b</b>	Enter the date of the master pool bond ▶ (MM/DD/YYYY) _____		
<b>c</b>	Enter the EIN of the issuer of the master pool bond ▶ _____		
<b>d</b>	Enter the name of the issuer of the master pool bond ▶ _____		
<b>39</b>	If the issuer has designated the issue under section 265(b)(3)(B)(i)(III) (small issuer exception), check box <input type="checkbox"/>		
<b>40</b>	If the issuer has elected to pay a penalty in lieu of arbitrage rebate, check box <input type="checkbox"/>		
<b>41a</b>	If the issuer has identified a hedge, check here <input type="checkbox"/> and enter the following information:		
<b>b</b>	Name of hedge provider ▶ _____		
<b>c</b>	Type of hedge ▶ _____		
<b>d</b>	Term of hedge ▶ _____		
<b>42</b>	If the issuer has superintegrated the hedge, check box <input type="checkbox"/>		
<b>43</b>	If the issuer has established written procedures to ensure that all nonqualified bonds of this issue are remediated according to the requirements under the Code and Regulations (see instructions), check box <input checked="" type="checkbox"/>		
<b>44</b>	If the issuer has established written procedures to monitor the requirements of section 148, check box <input checked="" type="checkbox"/>		
<b>45a</b>	If some portion of the proceeds was used to reimburse expenditures, check here <input checked="" type="checkbox"/> and enter the amount of reimbursement . . . . . ▶ <u>\$356,675</u>		
<b>b</b>	Enter the date the official intent was adopted ▶ (MM/DD/YYYY) <u>prelim exp</u>		

**Signature and Consent**

Under penalties of perjury, I declare that I have examined this return and accompanying schedules and statements, and to the best of my knowledge and belief, they are true, correct, and complete. I further declare that I consent to the IRS's disclosure of the issuer's return information, as necessary to process this return, to the person that I have authorized above.

▶ \_\_\_\_\_ Date \_\_\_\_\_ ▶ Jason Schadt, Finance Director  
 Signature of issuer's authorized representative Type or print name and title

<b>Paid Preparer Use Only</b>	Print/Type preparer's name	Preparer's signature	Date	Check <input type="checkbox"/> if self-employed	PTIN
	<u>J. Eric Boehlert</u>				<u>P01077288</u>
	Firm's name ▶ <u>Ahlers &amp; Cooney, P.C.</u>			Firm's EIN ▶	<u>42-1323559</u>
	Firm's address ▶ <u>100 Court Ave., Ste. 600, Des Moines, Iowa 50309</u>			Phone no.	<u>515-243-7611</u>

## **PAYING AGENT; BOND REGISTRAR AND TRANSFER AGENT AGREEMENT**

THIS AGREEMENT is made and entered into on March 26, 2026 by and between the City of Bettendorf hereinafter called "ISSUER", and UMB Bank, N.A., a national banking association with its principal payment office in Kansas City, Missouri, in its capacity as paying agent and registrar, hereinafter called the "AGENT".

WHEREAS, the ISSUER has issued, or is currently in the process of issuing, pursuant to an ordinance, resolution, order, final terms certificate, notice of sale or other authorizing instrument of the governing body of the ISSUER, hereinafter collectively called the "Bond Document" certain bonds, certificates, notes and/or other debt instruments, more particularly described as \$19,745,000 General Obligation Bonds, Series 2026A, dated March 26, 2026 hereinafter called the "Bonds"; and

WHEREAS, pursuant to the Bond Document, the ISSUER has designated and appointed the AGENT as agent to perform registrar, transfer and paying agent services, to wit: establishing and maintaining a record of the owners of the Bonds, effecting the transfer of ownership of the Bonds in an orderly and efficient manner, making payments of principal and interest when due pursuant to the terms and conditions of the Bonds, and for other related purposes; and

WHEREAS, the AGENT has represented that it possesses the necessary qualifications and maintains the necessary facilities to properly perform the required services as such registrar, transfer and paying agent and is willing to serve in such capacities for the ISSUER;

NOW THEREFORE, in consideration of mutual promises and covenants herein contained the parties agree as follows:

1. The ISSUER has designated and appointed the AGENT as registrar, transfer and paying agent of the Bonds pursuant to the Bond Document, and the AGENT has accepted such appointment and agrees to provide the services set forth therein and herein.
2. The ISSUER agrees to deliver or cause to be delivered to the AGENT a transcript of the proceedings related to the Bonds to contain the following documents:
  - (a) A copy of the Bond Document, and the consent or approval of any other governmental or regulatory authority, required by law to approve or authorize the issuance of the Bonds;
  - (b) A written opinion by an attorney or by a firm of attorneys with a nationally recognized standing in the field of municipal bond financing, and any supporting or supplemental opinions, to the effect that the Bonds and the Bond Document have been duly authorized and issued by, are legally binding upon and are enforceable against the ISSUER;
  - (c) A closing certificate of the ISSUER, a closing certificate and/or receipt of the purchaser(s) of the Bonds, and such other documents related to the issuance of the Bonds as the Agent reasonably deems necessary or appropriate; and

(d) Unless Paragraph 20 hereof is applicable and if requested in writing by AGENT, in addition to the transcript of proceedings a reasonable supply of blank Bond certificates bearing the manual or facsimile signatures of officials of the ISSUER authorized to sign certificates and, if required by the Bond Document, impressed with the ISSUER's seal or facsimile thereof, to enable the AGENT to provide Bond Certificates to the holders of the Bonds upon original issuance or the transfer thereof.

The foregoing documents may be subject to the review and approval of legal counsel for the AGENT. Furthermore, the ISSUER shall provide to the AGENT prompt written notification of any future amendment or change in respect of any of the foregoing, together with such documentation as the AGENT reasonably deems necessary or appropriate.

3. Unless Paragraph 20 hereof is applicable, Bond certificates provided by the ISSUER shall be printed in a manner to minimize the possibility of counterfeiting. This requirement shall be deemed satisfied by use of a certificate format meeting the standard developed by the American National Standards Committee or in such other format as the AGENT may accept by its authentication thereof. The AGENT shall have no responsibility for the form or contents of any such certificates. The ISSUER shall, while any of the Bonds are outstanding, provide a reasonable supply of additional blank certificates at any time upon request of the AGENT. All such certificates shall satisfy the requirements set forth in Paragraphs 2(d) and 3.

4. The AGENT shall initially register and authenticate, pursuant to instructions from the ISSUER and/or the initial purchaser(s) of the Bonds, one or more Bonds and shall enter into a Bond registry record the certificate number of the Bond and the name and address of the owner. The AGENT shall maintain such registry of owners of the Bonds until all the Bonds have been fully paid and surrendered. The initial owner of each Bond as reflected in the registry of owners shall not be changed except upon transfers of ownership and in accordance with procedures set forth in the Bond Document or this Agreement.

5. Transfers of ownership of the Bonds shall be made by the AGENT as set forth in the Bond Document. Absent specific guidelines in the Bond Document, transfers of ownership of the Bonds shall be made by the AGENT only upon delivery to the AGENT of a properly endorsed Bond or of a Bond accompanied by a properly endorsed transfer instrument, accompanied by such documents as the AGENT may deem necessary to evidence the authority of the person making the transfer, and satisfactory evidence of compliance with all applicable laws relating to the collection of taxes. The AGENT reserves the right to refuse to transfer any Bond until it is satisfied that each necessary endorsement is genuine and effective, and for that purpose it may require guarantees of signatures in accordance with applicable rules of the Securities and Exchange Commission and the standards and procedures of the AGENT, together with such other assurances as the AGENT shall deem necessary or appropriate. The AGENT shall incur no liability for delays in registering transfers as a result of inquiries into adverse claims or for the refusal in good faith to make transfers which it, in its judgment, deems improper or unauthorized. Upon presentation and surrender of any duly registered Bond and satisfaction of the transferability requirements, the AGENT shall (a) cancel the surrendered Bond; (b) register a new Bond(s) as directed in the same aggregate principal amount and

maturity; (c) authenticate the new Bond(s); and (d) enter the transferee's name and address, together with the certificate number of the new Bond(s), in its registry of owners.

6. The AGENT may deliver Bonds by first class, certified, or registered mail, or by courier.

7. Ownership of, payment of the principal amount of, redemption premium, if any, and interest due on the Bonds, delivery of notices, and for all other purposes shall be subject to the provisions of the Bond Document. The AGENT shall have no responsibility to determine the beneficial owners of any Bonds and shall owe no duties to any such beneficial owners. Upon written request and reasonable notice from the ISSUER, the AGENT will mail, at the ISSUER's expense, notices or other communications from the ISSUER to the holders of the Bonds as recorded in the registry maintained by the AGENT.

8. Unless the Bond Document provides otherwise, the ISSUER shall, without notice from or demand of the AGENT, provide to the AGENT funds that are immediately available at least one business day prior to the relevant interest and/or principal payment date, sufficient to pay on each interest payment date and each principal payment date, all interest and principal then payable under the terms and provisions of the Bond Document and the Bonds. The AGENT shall have no responsibility to make any such payments to the extent ISSUER has not provided sufficient immediately available funds to AGENT on the relevant payment date. In the event that an interest and/or principal payment date shall be a date that is not a business day, payment may be made on the next succeeding business day and no interest shall accrue. The term "business day" shall include all days except Saturdays, Sundays and legal holidays recognized by the Federal Reserve Bank of Kansas City, Missouri.

9. Unless otherwise provided in the Bond Document and subject to the provisions of Paragraph 12 hereof, to the extent that the ISSUER has made sufficient funds available to it, the AGENT will pay to the record owners of the Bonds as of any record date (as specified in the Bond certificate or Bond Document) the interest due thereon as of the related interest payment date or any redemption date and, will pay upon presentation and surrender of such Bond at maturity or earlier date of redemption to the owner of any Bond, the principal or redemption amount of such Bond.

10. The AGENT may make a charge against any Bond owner sufficient for the reimbursement of any governmental tax or other charge legally required to be withheld for any reason, including, but not limited to, failure of such owner to provide a correct taxpayer identification number to the AGENT. Such charge may be deducted from an interest or principal payment due to such owner.

11. Unless payment of interest, principal, and redemption premium, if any, is made by electronic transfer all payments will be made by check or draft and mailed to the address of the owner as reflected on the registry of owners, or to such other address as directed in writing by the owner.

12. Subject to the provisions of the Bond Document, the AGENT may pay at maturity or redemption or issue new certificates to replace certificates represented to the AGENT to have

been lost, destroyed, stolen or otherwise wrongfully taken, but may first may require the Bond owner to pay a replacement fee, to furnish an affidavit of loss, and/or furnish either an indemnity bond or other indemnification satisfactory to the AGENT indemnifying the ISSUER and the AGENT.

13. The AGENT shall comply with the provisions, if any, of the Bond Document and the rules of the Securities and Exchange Commission pertaining to the cancellation and retention of Bond certificates and the periodic certification to the ISSUER of the cancellation of such Bond certificates. In the event that the ISSUER requests in writing that the AGENT forward to the ISSUER the cancelled Bond certificates, the ISSUER agrees to comply with the foregoing described rules. The AGENT shall have no duty to retain any documents or records pertaining to this Agreement, the Bond Document or the Bonds any longer than eleven years after final maturity of the Bonds, unless otherwise required by the rules of the Securities and Exchange Commission or other applicable law.

14. The records maintained by AGENT in connection with the Bonds shall remain confidential records entitled to protection and confidentiality pursuant to Section 22.7(17), Code of Iowa. AGENT agrees that its use of the records will be limited to the purposes of this Agreement and that AGENT will make no private use or permit any private access thereto without the prior written consent of the ISSUER, which shall not be unreasonably withheld.

15. The AGENT is authorized to act on the order, directions or instructions of such officials as the governing body of ISSUER as the ISSUER by resolution or other proper action shall designate. The AGENT shall be protected in acting upon any paper or document believed by it to be genuine and to have been signed by the proper official(s), and the ISSUER shall promptly notify AGENT in writing of any change in the identity or authority of officials authorized to sign Bond certificates, written instructions or requests. If not so provided in the Bond Document, if any official whose manual or facsimile signature appears on blank Bond certificates shall die, resign or be removed from office or authority before the authentication of such certificates by the Agent, the AGENT may nevertheless issue such certificates until specifically directed to the contrary in writing by the ISSUER.

16. The AGENT shall provide notice(s) to the owners of the Bonds and such depositories, banks, brokers, rating agencies, information services, repositories, or publications as required by the terms of the Bond Document and to any other entities that request such notice(s) and, if so directed in such other manner and to such other parties as the ISSUER shall so direct in writing and at the expense of the ISSUER.

17. The ISSUER shall compensate the AGENT for the AGENT's ordinary services as paying agent and registrar, and shall reimburse the AGENT for all ordinary out-of-pocket expenses, charges, advances, counsel fees and other costs incurred in connection with the Bonds, the Bond Document and this Agreement as set forth in the Exhibit A or as otherwise agreed to by the ISSUER and AGENT in writing. In addition, should it become necessary for the AGENT to perform extraordinary services, the AGENT shall be entitled to extra compensation therefor and reimbursement for any out-of-pocket extraordinary costs and expenses, including, but not limited to, attorneys' fees. AGENT shall use commercially reasonable efforts to provide notice to the Issuer prior to performing extraordinary services or incurring such costs and expenses; provided,

however, that AGENT's right to compensation hereunder shall not be affected by any failure to provide such prior notice.

18. The AGENT may resign, or be removed by the ISSUER upon a date which, unless otherwise waived by the other party, is (a) at least thirty days after the receipt of written notice to the other and (b) in the case such notice is given by the AGENT, at least fifteen days prior to the next succeeding principal or interest payment date. Upon the effective date of resignation or removal, all obligations of the AGENT hereunder shall cease and terminate, but AGENT shall not be discharged from any liability for actions taken as AGENT under this Agreement prior to such resignation or removal. In the event of resignation or removal, the AGENT shall deliver the registry of owners and all related books and records in accordance with the written instructions of the ISSUER or any successor agent designated in writing by the ISSUER within a reasonable period following the effective date of its removal or resignation.

19. Whenever in the performance of its duties as Agent hereunder, the Bond Document or under the Bonds the AGENT shall deem it desirable that a matter be proved or established prior to taking, suffering or omitting any action hereunder, under the Bond Document or under the Bonds, the AGENT may consult with nationally recognized legal counsel in accordance with its internal policies and procedures, including, but not limited to, legal counsel for the ISSUER, with respect to any matter in connection with this Agreement and it shall not be liable for any action taken or omitted by it in good faith in reliance upon the advice or opinion of such counsel.

20. In the event that the Bond Document provides that the initial registered owner of all of the Bond certificates is or may be the Depository Trust Company, or any other securities depository or registered clearing agency qualified under the Securities and Exchange Act of 1934, as amended (a "Securities Depository"), none of the beneficial owners will receive certificates representing their respective interest in the Bonds. Except to the extent provided otherwise in the Bond Document, the following provisions shall apply:

(a) The registry of owners maintained by the AGENT will reflect as owner of the Bonds only the Securities Depository or its nominee, until and unless the ISSUER authorizes the delivery of Bond certificates to the beneficial owners as described in subsection (d) below.

(b) It is anticipated that during the term of the Bonds, the Securities Depository will make book-entry transfers among its participants and receive and transmit payments of principal and interest on the Bonds to the participants, unless and until the ISSUER authorizes the delivery of Bonds to the beneficial owners as described in subsection (d) below.

(c) The ISSUER may at any time, in accordance with the Bond Document, select and appoint a successor Securities Depository and shall notify the Agent of such selection and appointment in writing.

(d) If the ISSUER determines that the holding of the Bonds by the Securities Depository is no longer in the best interests of the beneficial owners of the Bonds, then

the AGENT, at the written instruction and expense of the ISSUER, shall notify the beneficial owners of the Bonds by first class mail of such determination and of the availability of certificates to owners requesting the same. The AGENT shall register in the names of and authenticate and deliver certificates representing their respective interests in the Bonds to the beneficial owners or their nominees, in principal amounts and maturities representing the interest of each, making such adjustments as it may find necessary or appropriate as to accrued interest and previous calls for redemption. In such event, all references to the Securities Depository herein shall relate to the period of time when at least one Bond is registered in the name of the Securities Depository or its nominee. For the purposes of this paragraph, the AGENT may conclusively rely on information provided by the Securities Depository and its participants as to principal amounts held by and the names and mailing addresses of the beneficial owners of the Bonds, and shall not be responsible for any investigation to determine the beneficial owners. The cost of printing certificates for the Bonds and expenses of the AGENT shall be paid by the ISSUER.

21. The AGENT shall not be liable for any error in judgment in fulfilling its obligations under this Agreement or the Bond Document that is made in good faith by an officer or employee of the AGENT unless it shall be determined by a court of competent jurisdiction that the AGENT was negligent in ascertaining the pertinent facts or acted intentionally in bad faith. The AGENT shall not be under any obligation to prosecute or defend any action or suit in connection with its duties under the Bond Document or this Agreement or in respect of the Bonds, which, in its opinion, may involve it in expense or liability, unless satisfactory security and indemnity is furnished to the Agent (except as may result from the AGENT's own negligence or willful misconduct). The AGENT shall only be responsible for performing such duties as are set forth herein, required by the Bond Document, or otherwise agreed to in writing by the AGENT.

22. It is mutually understood and agreed that, unless otherwise provided in the Bonds or Bond Document, this Agreement shall be governed by the laws of the State of Iowa, both as to interpretation and performance.

23. The Bond Document and the terms thereof are hereby incorporated by reference and the provisions of this Agreement are to be construed to be consistent with the Bond Document. In the event of inconsistent language between the Bond Document and this Agreement, the terms of the Bond Document shall prevail.

24. AGENT shall comply at all times with such rules, regulations, and requirements as may govern the registration, transfer and payment of registered bonds including without limitation Chapters 76, 384, 403, and Section 554.8101 et seq. Code of Iowa and standards issued from time to time by the Municipal Securities Rulemaking Board of the United States and any other securities industry standard and the requirements of the Internal Revenue Code of 1986.

25. In the event any payment check representing payment of interest or principal on the Bonds is returned to the AGENT or is not presented for payment, or if any Bond is not presented for payment of principal or premium, if any, at the maturity or redemption date, if



29. The parties hereto agree that the transactions described herein may be conducted and related documents may be sent, received or stored by electronic means. Copies, telecopies, facsimiles, electronic files and other reproductions of original executed documents shall be deemed to be authentic and valid counterparts of such original documents for all purposes, including the filing of any claim, action or suit in the appropriate court of law.

30. In order to comply with provisions of the USA PATRIOT Act of 2001, as amended from time to time, and the Bank Secrecy Act, as amended from time to time, the AGENT may request certain information and/or documentation to verify confirm and record identification of persons or entities who are parties to this Agreement.

31. If the Bonds are eligible for receipt of any U.S. Treasury Interest Subsidy and if so directed by the Bond Document or, as agreed to in writing between the ISSUER and the AGENT, the AGENT shall comply with the provisions, if any, relating to it as described in the Bond Document or as otherwise agreed upon in writing between the ISSUER and the AGENT. The AGENT shall not be responsible for completion of or the actual filing of Form 8038-CP (or any successor form) with the IRS or any payment from the United States Treasury in accordance with §§ 54AA and 6431 of the Code.

**IN WITNESS WHEREOF**, the parties hereto have, by their duly authorized signatories, set their respective hands and seals as of this 26<sup>th</sup> day of March, 2026.

CITY OF BETTENDORF,  
STATE OF IOWA, ISSUER

By: \_\_\_\_\_  
Mayor

ATTEST:

By: \_\_\_\_\_  
City Clerk

UMB BANK N.A., as PAYING  
AGENT/REGISTRAR

By: \_\_\_\_\_

ATTEST:

By: \_\_\_\_\_

\_\_\_\_\_  
(Title)

\_\_\_\_\_  
(Title)

EXHIBIT A

Paying Agent/Registrar's Fee

4922-4202-9968-1\10216-112

## COUNCIL LETTER

**MEETING DATE:** March 3, 2026  
**REQUESTED BY:** Pat Lynch, P.E., Assistant City Engineer



---

### Item Title

Resolution setting the date for a public hearing and directing the advertising for bids for the 2026 Pavement Markings Program.

### Explanation

The proposed improvements consist of painting pavement markings on various streets throughout the City. The markings include edge lines, centerlines, barrier lines, double yellow lines, turn lane lines at intersections, crosswalks, and symbols. To enhance visibility and overall safety on our roadways, the markings will be completed two (2) times during the year, once in the late spring and once in the early fall.

Relationship to Goals: Upgraded City Infrastructure & Public Facilities.

### **If the matter is not budgeted in the current year, explain why funding is requested and the anticipated source:**

This project (RU0058) was approved with a total budget of \$125,000 within the Community Improvement Program (CIP).

### List Attachments

Resolution; Notice to Bidders; Notice of Public Hearing.

**RESOLUTION SETTING THE DATE FOR A PUBLIC HEARING AND DIRECTING THE ADVERTISING FOR BIDS FOR THE 2026 PAVEMENT MARKINGS PROGRAM**

WHEREAS, this Council deems it necessary and advisable under the provisions of the Code of Iowa to construct certain improvements to the street system of Bettendorf, Iowa, namely, the

2026 Pavement Markings Program

as hereinafter described and has ordered plans, specifications, form of contract and engineer's estimate to be prepared and said documents are now on file in the office of the City Engineer for public inspection.

NOW, THEREFORE BE IT RESOLVED that the council will conduct a public hearing on the final adoption of the plans, specifications, notice to bidders, and form of contract for the construction of the improvements in the City Hall Council Chambers, 1609 State Street, Bettendorf, Iowa at 7:00 o'clock p.m. on the 17<sup>th</sup> day of March, 2026, and the City Clerk is hereby directed to give notice of the hearing, said notice to be published at least once as provided by law, not less than four (4) nor more than twenty (20) days before the date fixed for the hearing.

BE IT FURTHER RESOLVED that the City Engineer be authorized to receive bids for the construction of said improvements through the electronic bid submission system at <https://bettendorf.ionwave.net> until 10:00 o'clock a.m. on the 31<sup>st</sup> day of March, 2026, and the City Clerk is hereby directed to give notice to the taking of bids, said notice is to be posted in a relevant contractor plan room service with statewide circulation, a relevant construction lead generating service with statewide circulation and on the City's website with such publication to be not less than thirteen (13) days nor more than forty five (45) days before the date of the letting.

BE IT FURTHER RESOLVED that a cashier's or certified check, Credit Union Certified Share Draft, or bid bond to accompany each bid, as security, be submitted with the bid. The bidder will enter into a contract for the work bid upon and will furnish a corporate surety bond acceptable to the Council for faithful performance of the contract, in the amount of ten percent (10%) of the bid amount.

Passed, Approved and Adopted this 3<sup>rd</sup> day of March 2026.

---

Robert S. Gallagher, Mayor

Attest:

---

Decker P. Ploehn, City Clerk

## NOTICE TO BIDDERS

Sealed bids will be received by the City of Bettendorf, Iowa, through their electronic bid submission system at <https://bettendorf.ionwave.net> until **10:00 A.M.** on the **31<sup>st</sup> day of March, 2026**, for the **2026 Pavement Markings Program** and related work as described in the plans and specifications now on file in the office of the City Clerk. Bids shall be submitted to the City Council for consideration and action at a subsequent meeting.

The proposed improvements consist of painting pavement markings on various streets throughout the City. The markings include edge lines, centerlines, barrier lines, double yellow lines, turn lane lines at intersections, crosswalks, and symbols. Work in school zones shall not begin before 8:30 am while school is in session.

The bidder to whom the Contract is awarded shall commence work no later than the date to begin work set forth in a Notice to Proceed from the City or its authorized representative, to the Contractor. All work shall be done in strict compliance with the plans and specifications prepared by the Engineer of the Engineering Division of the Public Works Department of Bettendorf, Iowa.

All work on this contract shall be completed in two applications. The first application shall start on or after April 20, 2026 and be completed by June 27, 2026. The second application shall start on or after September 14, 2026 and be completed by November 14, 2026. The first application includes all lane lines, symbols and crosswalks. The second application will only include the lane lines. Once started, the contractor shall have 40 working days to complete the first application and 20 working days for the second application. Both applications must be completed by the completion dates listed above, regardless of remaining working days. The beginning and completion dates will be included in and made part of the contract between the successful bidder and the City. Liquidated damages in the amount of Five Hundred Dollars and no/100 (\$500.00) per calendar day shall be charged for every day past the completion date.

The plans, specifications and all bid documents, hereinafter called proposed Contract Documents, are placed on file and are available for inspection on the City of Bettendorf's electronic bid submission website: <https://bettendorf.ionwave.net>. If you haven't already done so, you will need to register as a supplier at the website to submit a bid. All bids must be submitted electronically. No paper, emailed, or faxed bids will be accepted, and no physical bid opening shall be held. All bids will be evaluated by the City's electronic bid submission system.

Copies of the proposed Contract Documents for said improvements may be obtained with a forty-eight (48) hour notice at the Engineering Division of Public Works, 4403 Devils Glen Rd., Bettendorf, Iowa by calling (563) 344-4055. Paper sets require a refundable deposit of Two Hundred Fifty Dollars (\$250.00) for each set that shall be refunded within fourteen (14) days after the award of the project. If the Contract Documents are not returned in a timely manner and in a reusable condition, the deposit, or portions thereof, may be forfeited.

Each proposal must be accompanied by a certified or cashier's check drawn on an Iowa bank or a bank chartered under the laws of the United States or by a Bid Bond with corporate surety satisfactory to the City of Bettendorf in the amount of ten (10) percent of the bid, made payable to the City Treasurer of the City of Bettendorf, Iowa, and may be cashed or claim made against the bond by the Treasurer of the City of Bettendorf, Iowa, as liquidated damages in the event the successful bidder fails to enter into a contract within ten (10) days and post bond satisfactory to the City for the faithful performance of the work. Checks or Bid Bonds of the three lowest bidders may be retained for a period of not to exceed thirty (30)

days or until a contract is awarded or rejection is made, whichever is sooner. Other checks and Bid Bonds will be returned after the tabulation of the bids is completed.

The successful bidder will be required to furnish a performance and maintenance bond equal to One Hundred Percent (100%) of the contract price. Said bond is to be issued by a responsible surety approved by the City Council and shall guarantee the faithful performance of the contract and shall also guarantee the maintenance of the improvement for a period of one (1) year from and after its completion and acceptance by the City.

Contractors and subcontractors on this project will undergo a standardized evaluation upon completion of the work. The results of this evaluation may influence the determination of the contractor's eligibility to bid on future projects as governed by the current policies adopted by the City of Bettendorf City Council.

By virtue of statutory authority, a preference will be given to products and provisions grown and coal produced within the State of Iowa and to Iowa domestic labor. A preference will be given to resident Bidders in Accordance with Chapter 73 of the Code of Iowa.

Plans and specifications governing the construction of the proposed improvements and also prior proceedings of the City Council referring to and defining said proposed improvements are hereby made a part of this notice and the proposed contract shall be executed in compliance therewith.

The City reserves the right to reject any or all proposals and to waive technicalities and irregularities if deemed necessary and approved by City Council.

Published upon order of the City Council of Bettendorf, Iowa.

Brent Morlok, P.E.  
City Engineer

## **NOTICE OF PUBLIC HEARING**

### **To Whom It May Concern:**

Notice is hereby given that on the 17th day of March, 2026, at 7:00 p.m., the City Council of the City of Bettendorf, Iowa, will conduct a public hearing at City Hall, Council Chambers, 1609 State Street, regarding plans, specifications, notice to bidders, and form of contract for the construction of the improvements for the 2026 Pavement Markings Program.

The City Council has set said hearing at the time and place specified. Written suggestions or objections concerning this issue may be filed with the City Clerk at or before such hearing and will be heard by the City Council at the time and place specified.

Interested persons desiring to present their views upon the issue, either in writing or verbally, will be given the opportunity to be heard at the above-mentioned time and place.

Dated at Bettendorf, Iowa, this 3rd day of March, 2026

Decker P. Ploehn, City Clerk

## COUNCIL LETTER

**MEETING DATE:** March 3, 2026  
**REQUESTED BY:** Pat Lynch, P.E., Assistant City Engineer



### Item Title

Resolution setting the date for a public hearing and directing the advertising for bids for the 2026 Pavement Preservation Program.

### Explanation

The proposed improvements consist of applying approximately 27,875 square yards of Gilsonite/Polymer Enhanced Penetrating Restoring Asphalt Emulsion directly to the surface of recently paved hot mix asphalt streets within the City of Bettendorf, Iowa. The product restores the initial loss of color due to oxidation and fills any micro-cracking that may have appeared over the winter. A list of streets to be completed under this year's program is noted below.

### 2026 Pavement Preservation List

WARD	LOCATION	FROM	TO
3	Dundee Lane	Stafford Boulevard	29th Street
4	Aspen Hills Drive	Apple Valley Drive	PCC Header S. of New Lexington Ct.
4	New Lexington Drive	18th Street	Aspen Hills Drive
4	Lexington Court	New Lexington Drive	Cul de sac
4	Kingsway Drive	18th Street	Cul de sac
4	Keeneland Court	Kingsway Drive	Cul de sac
3	Corral Court	Belmont Road	Cul de sac
1	Wildwood Trail	Lincoln Road	Cul de sac
3	Camden Drive	Stafford Boulevard	29th Street
2	Hillcrest Avenue	Olympia Drive	Spruce Hills Drive
1	Parklane Circle	Fairlane Drive	North around Circle
1	Alley	15th St to 16th St	Mississippi Blvd & Central Ave
1	Alley	16th St to 17th St	Brown St & Mississippi Blvd
1	Alley	17th St to 18th St	Brown St & Mississippi Blvd
1	Alley	18th St to Mississippi Blvd	Brown St & Mississippi Blvd
1	Alley	15th St to 16th St	Grant St & Brown St
1	Alley	8th St to 10th St	Jones St & Hall St

1	Alley	8th St to Applestone St	Holmes St & Jones St
1	Alley	21st St to 23rd St	Bellevue Ave & Oak St
1	Alley	28th St to 29th St	Central Ave & Bellevue Ave

Relationship to Goals: Upgraded City Infrastructure & Public Facilities.

**If the matter is not budgeted in the current year, explain why funding is requested and the anticipated source:**

This project (RU0061) was approved with a total budget of \$100,000 within the Community Improvement Program (CIP).

**List Attachments**

Resolution; Notice to Bidders; Notice of Public Hearing.

**RESOLUTION SETTING THE DATE FOR A PUBLIC HEARING AND DIRECTING THE ADVERTISING FOR BIDS FOR THE 2026 PAVEMENT PRESERVATION PROGRAM**

WHEREAS, this Council deems it necessary and advisable under the provisions of the Code of Iowa to construct certain improvements to the street system of Bettendorf, Iowa, namely, the

2026 Pavement Preservation Program

as hereinafter described and has ordered plans, specifications, form of contract and engineer's estimate to be prepared and said documents are now on file in the office of the City Engineer for public inspection.

NOW, THEREFORE BE IT RESOLVED that the council will conduct a public hearing on the final adoption of the plans, specifications, notice to bidders, and form of contract for the construction of the improvements in the City Hall Council Chambers, 1609 State Street, Bettendorf, Iowa at 7:00 o'clock p.m. on the 17<sup>th</sup> day of March, 2026, and the City Clerk is hereby directed to give notice of the hearing, said notice to be published at least once as provided by law, not less than four (4) nor more than twenty (20) days before the date fixed for the hearing.

BE IT FURTHER RESOLVED that the City Engineer be authorized to receive bids for the construction of said improvements through the electronic bid submission system at <https://bettendorf.ionwave.net> until 10:00 o'clock a.m. on the 31<sup>st</sup> day of March, 2026, and the City Clerk is hereby directed to give notice to the taking of bids, said notice is to be posted in a relevant contractor plan room service with statewide circulation, a relevant construction lead generating service with statewide circulation and on the City's website with such publication to be not less than thirteen (13) days nor more than forty five (45) days before the date of the letting.

BE IT FURTHER RESOLVED that a cashier's or certified check, Credit Union Certified Share Draft, or bid bond to accompany each bid, as security, be submitted with the bid. The bidder will enter into a contract for the work bid upon and will furnish a corporate surety bond acceptable to the Council for faithful performance of the contract, in the amount of ten percent (10%) of the bid amount.

Passed, Approved and Adopted this 3<sup>rd</sup> day of March 2026.

---

Robert S. Gallagher, Mayor

Attest:

---

Decker P. Ploehn, City Clerk

## NOTICE TO BIDDERS

Sealed bids will be received by the City of Bettendorf, Iowa, through their electronic bid submission system at <https://bettendorf.ionwave.net> until **10:00 A.M.** on the **31st day of March, 2026**, for the **2026 Pavement Preservation Program** and related work as described in the plans and specifications now on file in the office of the City Clerk. Bids shall be submitted to the City Council for consideration and action at a subsequent meeting.

The proposed improvements consist of applying approximately 27,875 square yards of Gilsonite/Polymer Enhanced Penetrating Restoring Asphalt Emulsion directly to the surface of recently paved hot mix asphalt streets within the City of Bettendorf, Iowa.

Before the start of construction, the Contractor shall submit a line of march and schedule of his/her work listing critical path items. The list of items shall establish a time schedule for the program.

**No work shall start on any street without the approval from the Engineer or his representative.**

All work shall be done in strict compliance with the plans and specifications prepared by the Engineer of the Engineering Division of the Public Works Department of Bettendorf, Iowa.

All work on this contract shall commence on or after June 8, 2026, as weather permits. All work on this contract shall be completed by August 14, 2026. The beginning and completion dates will be included in and made part of the contract between the successful bidder and the City. Liquidated damages in the amount of Five Hundred Dollars and no/100 (\$500.00) per calendar day shall be charged for every day past the completion date.

The plans, specifications and all bid documents, hereinafter called proposed Contract Documents, are placed on file and are available for inspection on the City of Bettendorf's electronic bid submission website: <https://bettendorf.ionwave.net>. If you haven't already done so, you will need to register as a supplier at the website to submit a bid. All bids must be submitted electronically. No paper, emailed, or faxed bids will be accepted, and no physical bid opening shall be held. All bids will be evaluated by the City's electronic bid submission system.

Copies of the proposed Contract Documents for said improvements may be obtained with a forty-eight (48) hour notice at the Engineering Division of Public Works, 4403 Devils Glen Rd., Bettendorf, Iowa by calling (563) 344-4055. Paper sets require a refundable deposit of Two Hundred Fifty Dollars (\$250.00) for each set that shall be refunded within fourteen (14) days after the award of the project. If the Contract Documents are not returned in a timely manner and in a reusable condition, the deposit, or portions thereof, may be forfeited.

Each proposal must be accompanied by a certified or cashier's check drawn on an Iowa bank or a bank chartered under the laws of the United States or by a Bid Bond with corporate surety satisfactory to the City of Bettendorf in the amount of ten (10) percent of the bid, made payable to the City Treasurer of the City of Bettendorf, Iowa, and may be cashed or claim made against the bond by the Treasurer of the City of Bettendorf, Iowa, as liquidated damages in the event the successful bidder fails to enter into a contract within ten (10) days and post bond satisfactory to the City for the faithful performance of the work. Checks or Bid Bonds of the three lowest bidders may be retained for a period of not to exceed thirty (30) days or until a contract is awarded or rejection is made, whichever is sooner. Other checks and Bid Bonds will be returned after the tabulation of the bids is completed.

The successful bidder will be required to furnish a performance and maintenance bond equal to One Hundred Percent (100%) of the contract price. Said bond is to be issued by a responsible surety approved by the City Council and shall guarantee the faithful performance of the contract and shall also guarantee the maintenance of the improvement for a period of four (4) years from and after its completion and acceptance by the City.

Contractors and subcontractors on this project will undergo a standardized evaluation upon completion of the work. The results of this evaluation may influence the determination of the contractor's eligibility to bid on future projects as governed by the current policies adopted by the City of Bettendorf City Council.

By virtue of statutory authority, a preference will be given to products and provisions grown and coal produced within the State of Iowa and to Iowa domestic labor. A preference will be given to resident Bidders in Accordance with Chapter 73 of the Code of Iowa.

Plans and specifications governing the construction of the proposed improvements and also prior proceedings of the City Council referring to and defining said proposed improvements are hereby made a part of this notice and the proposed contract shall be executed in compliance therewith.

The City reserves the right to reject any or all proposals and to waive technicalities and irregularities if deemed necessary and approved by City Council.

Published upon order of the City Council of Bettendorf, Iowa.

Brent Morlok, P.E.  
City Engineer

## **NOTICE OF PUBLIC HEARING**

### **To Whom It May Concern:**

Notice is hereby given that on the 17th day of March, 2026, at 7:00 p.m., the City Council of the City of Bettendorf, Iowa, will conduct a public hearing at City Hall, Council Chambers, 1609 State Street, regarding plans, specifications, notice to bidders, and form of contract for the construction of the improvements for the 2026 Pavement Preservation Program.

The City Council has set said hearing at the time and place specified. Written suggestions or objections concerning this issue may be filed with the City Clerk at or before such hearing and will be heard by the City Council at the time and place specified.

Interested persons desiring to present their views upon the issue, either in writing or verbally, will be given the opportunity to be heard at the above-mentioned time and place.

Dated at Bettendorf, Iowa, this 3rd day of March, 2026

Decker P. Ploehn, City Clerk

## **COUNCIL LETTER**

**MEETING DATE:** March 3, 2026

**REQUESTED BY:** Austin Whelan, Transit Operations Manager



---

### **Item Title**

Resolution setting the date for a public hearing on the FY2027 application for State Transit Assistance funds for Transit System Operations.

### **Explanation**

Each year, State Transit Assistance funds are available to the City of Bettendorf to support transit system operations. A grant application must be submitted in order to obtain this funding. The FY2027 State funding allocation for Bettendorf is estimated to be \$250,587.00 and the grant period will begin on July 1, 2026. These funds help the City continue providing a quality, responsive transit service to the citizens of Bettendorf.

The State requires a public hearing be held to allow persons the opportunity to speak in favor of, or in opposition to the grant application. The public hearing notice is to be published at least thirty (30) days prior to the public hearing.

**If the matter is not budgeted in the current year, explain why funding is requested and the anticipated source:**

### **List Attachments**

Resolution; Notice of Public Hearing.

**RESOLUTION NO: \_\_\_\_\_ -26**

**RESOLUTION SETTING THE DATE FOR A PUBLIC HEARING ON THE FY2027 APPLICATION FOR STATE TRANSIT ASSISTANCE FUNDS FOR TRANSIT SYSTEM OPERATIONS**

WHEREAS, the State of Iowa Office of Public Transit requires a public hearing to allow persons the opportunity to speak in favor of, or in opposition to, the submission of a grant.

NOW, THEREFORE BE IT RESOLVED BY THE CITY COUNCIL OF THE CITY OF BETTENDORF, IOWA, that the Council will conduct a public hearing on the advisability of submitting an application for State of Iowa Transit Operating Assistance in the amount of \$250,587.00 to be used for operational needs of the Bettendorf Transit System, in the Council Chambers of Bettendorf City Hall, 1609 State Street, Bettendorf, Iowa at 7:00 o'clock PM, Central Daylight Time, on the 7<sup>th</sup> day of April, 2026 and the City Clerk is hereby instructed to give notice of said hearing, said notice is to be published at least once as provided by law, not less than thirty (30) days before the date of the hearing.

Passed, Approved, and Adopted this 3<sup>rd</sup> day of March, 2026.

\_\_\_\_\_  
Robert S. Gallagher, Mayor

Attest:

\_\_\_\_\_  
Decker P. Ploehn, City Clerk

## **NOTICE OF PUBLIC HEARING**

### **TO WHOM IT MAY CONCERN:**

Notice is hereby given that on the 7th day of April, 2026 at 7:00 pm, the City Council of the City of Bettendorf, Iowa, will conduct a public hearing at City Hall, Council Chambers, 1609 State Street. The purpose of this hearing is to discuss an application from the City of Bettendorf to the Iowa Department of Transportation for financial assistance as follows:

The City of Bettendorf will submit an application for FY2027 State Transit Assistance to support transit operations in an amount of \$250,587.00.

The City Council has set said hearing at the time and place specified. Written suggestions or objections concerning this issue may be filed with the City Clerk at or before such hearing and will be heard by the City Council at the time and place specified.

Interested persons desiring to present their views upon this issue, either in writing or verbally, will be given the opportunity to be heard at the above-mentioned time and place.

Dated at Bettendorf, Iowa this 3<sup>rd</sup> day of March, 2026.

Decker P. Ploehn, City Clerk

## COUNCIL LETTER

**MEETING DATE:** March 3, 2026  
**REQUESTED BY:** Brian Schmidt, P.E., Director of Public Works



---

### Item Title

Resolution awarding the contract to Fisher Lawn Care, Inc. for the 2026 Citywide Landscape Planting and Maintenance Program.

### Explanation

This is an annual program for a landscape contractor to install annual flowers in previously landscaped areas in and around City parks, City facilities, and right-of-ways. The flower planting and maintenance services are for the City's Park Maintenance Division and will last until the end of the current years growing season.

Bids were received on February 24, 2026. Fisher Lawn Care, Inc. of Bettendorf, Iowa was the only contractor to submit a bid in the amount of \$27,000.00, which is the same price as quoted last season.

### **If the matter is not budgeted in the current year, explain why funding is requested and the anticipated source:**

This contract is funded within the Parks Maintenance operating budget (1001-0712-55081) with a total budget of \$230,000. This line item covers all beautification projects throughout the City. Pricing for all contracts this year has been very competitive and below budgeted amounts.

### List Attachments

Resolution, Bid Tabulation, and Contract.

**RESOLUTION NO. \_\_\_\_\_-26**

**RESOLUTION AWARDING THE CONTRACT TO FISHER LAWN CARE INC. FOR THE  
2026 CITYWIDE LANDSCAPE PLANTING AND MAINTENANCE PROGRAM**

WHEREAS, the City of Bettendorf issued a Request for Proposal for the installation of landscape planting and maintenance services at various locations within the City of Bettendorf; and

WHEREAS, bids were received for the 2026 Citywide Landscape Planting and Maintenance Program on the 24<sup>th</sup> day of February, 2026; and

WHEREAS, Fisher Lawn Care, Inc. was the only contractor to submit a bid in the amount of \$27,000.00; and

WHEREAS, the Contractor has submitted a proposal that meets the specifications detailed in the above referenced Request for Proposal.

NOW, THEREFORE BE IT RESOLVED BY THE CITY COUNCIL OF THE CITY OF BETTENDORF, IOWA that the proposal from Fisher Lawn Care, Inc. be accepted, and the Mayor and City Administrator are hereby authorized and directed to sign the contract for execution of said project.

Passed, Approved and Adopted this 3<sup>rd</sup> day of March, 2026.

\_\_\_\_\_  
Robert S. Gallagher, Mayor

Attest:

\_\_\_\_\_  
Decker P. Ploehn, City Clerk

**2026 Citywide Landscape Planting and Maintenance Program**

<b>Fisher Lawn Care (Lou &amp; Lor Inc.)</b>	
<b>Total Price</b>	<b>\$27,000.00</b>
<b>Unit</b>	<b>Extended</b>
\$12,000.00	\$12,000.00
\$15,000.00	\$15,000.00

<b>Line #</b>	<b>Description</b>	<b>QTY</b>	<b>UOM</b>	<b>Unit</b>	<b>Extended</b>
1	Citywide Landscape Planting	1	LS	\$12,000.00	\$12,000.00
2	Citywide Landscape Maintenance	1	LS	\$15,000.00	\$15,000.00

**FORM OF CONTRACT**

**THIS CONTRACT**, made the 3rd day of March A.D., 2026, by and between  
**Fisher Lawn Care, Inc.**, hereinafter called the "Contractor", and  
the City of Bettendorf, Scott County, Iowa, hereinafter called the "City",

WITNESSETH, That the Contractor and the City for the consideration stated herein agree as follows:

**ARTICLE I. SCOPE OF WORK** - The Contractor shall perform everything required to be performed and shall provide and furnish all of the labor, necessary tools, expendable equipment, and transportation required to perform and complete in a workmanlike manner all the work required in connection with the **2026 Citywide Landscape Planting and Maintenance Program**, all in strict accordance with the specifications, which are made a part of this contract; and in strict compliance with the Contractor's proposal and the other contract documents herein mentioned which are a part of this contract. The Contractor shall do everything required by this contract and the other documents constituting a part thereof.

**ARTICLE II. THE CONTRACT PRICE** - The City shall pay to the Contractor for the performance of this contract, subject to any additions or deductions provided therein, in current funds, the contract price of:

**Twenty-Seven Thousand Dollars and 00/100 Cents**

computed as follows:

**Mowing Base Bid**

Item	Description	Quantity	Units	Unit Price	Total Price
1	Citywide Landscape Planting	1	LS	\$12,000.00	\$12,000.00
2	Citywide Landscape Maintenance	1	LS	\$15,000.00	\$15,000.00

**Total Base Bid: \$27,000.00**

**ARTICLE III. UNIT PRICES FOR CHANGES**- Not applicable to this contract.

**ARTICLE IV. PAYMENTS**- Payments are to be made to the Contractor in accordance with and subject to the provisions embodied in the documents made a part of this Contract.

**ARTICLE V. CONTRACT TIME**- Work under this contract shall commence on the date specified in the written Notice to Proceed from the City, or its authorized representative, to the Contractor who shall diligently prosecute and complete all work under this contract as outlined in the Special Conditions, weather depending.

**ARTICLE VII. COMPONENT PARTS OF THIS CONTRACT** - This contract consists of the following component parts, all of which are as fully a part of this contract as if herein set out verbatim, or, if not attached, as if hereto attached.

- 1) Special Conditions
- 2) Contract with the City
- 3) Request for Proposal
- 4) Contractor's Proposal

In the event that any provision in any of the foregoing component parts of this contract conflicts with any provision in any other of the component parts, the provision in the component part first enumerated shall govern over any other component part which follows it numerically, except as may be otherwise specifically stated.

IN WITNESS WHEREOF, the parties hereto have caused this Instrument to be executed in three original counterparts the date and year first above written.

Fisher Lawn Care, Inc.  
\_\_\_\_\_  
(Contractor)  
  
By \_\_\_\_\_  
\_\_\_\_\_  
\_\_\_\_\_  
(Title)

ATTEST:  
  
\_\_\_\_\_  
\_\_\_\_\_  
\_\_\_\_\_  
(Title)

ATTEST: CITY OF BETTENDORF, IA  
  
\_\_\_\_\_  
Robert S. Gallagher  
Mayor

\_\_\_\_\_  
Decker P. Ploehn  
City Clerk

This Instrument approved by the City Council of the City of Bettendorf, Iowa, pursuant to Resolution Number \_\_\_\_\_ passed \_\_\_\_\_, 2026.

## COUNCIL LETTER

**MEETING DATE:** March 3, 2026  
**REQUESTED BY:** Brian Schmidt, P.E., Director of Public Works



---

### Item Title

Resolution awarding the contract to MB Lawn Care, LLC for the 2026 Citywide Landscape Mulching Program.

### Explanation

This is an annual program for the Contractor to purchase and place dyed brown shredded mulch in previously landscaped areas in and around City parks, City facilities, and right-of-ways. The mulching services are for the City's Park Maintenance Division and will last until the end of the current years planting season.

Bids were received on February 24, 2026. MB Lawn Care, LLC of Urbandale, Iowa was the low bidder of six (6) bids received. Bids ranged from the high of \$37,500.00 to the low of \$15,000.00.

### **If the matter is not budgeted in the current year, explain why funding is requested and the anticipated source:**

This contract is funded within the Parks Maintenance operating budget (1001-0712-55081) with a total budget of \$230,000. This line item covers all beautification projects throughout the City. Pricing for all contracts this year has been very competitive and below budgeted amounts.

### List Attachments

Resolution, Bid Tabulation, and Contract.

**RESOLUTION NO. \_\_\_\_\_-26**

**RESOLUTION AWARDING THE CONTRACT TO MB LAWN CARE, LLC FOR THE  
2026 CITYWIDE LANDSCAPE MULCHING PROGRAM**

WHEREAS, the City of Bettendorf issued a Request for Proposal for the purchase and installation of landscape mulching at various locations within the City of Bettendorf; and

WHEREAS, bids were received for the 2026 Citywide Landscape Mulching Program on the 24<sup>th</sup> day of February, 2026; and

WHEREAS, six (6) bids were received and MB Lawn Care, LLC was the low bidder in the amount of \$15,000.00; and

WHEREAS, the Contractor has submitted a proposal that meets the specifications detailed in the above referenced Request for Proposal.

NOW, THEREFORE BE IT RESOLVED BY THE CITY COUNCIL OF THE CITY OF BETTENDORF, IOWA that the proposal from MB Lawncare, LLC be accepted, and the Mayor and City Administrator are hereby authorized and directed to sign the contract for execution of said project.

Passed, Approved and Adopted this 3<sup>rd</sup> day of March, 2026.

---

Robert S. Gallagher, Mayor

Attest:

---

Decker P. Ploehn, City Clerk

2026 Citywide Landscape Mulching Program

				MB Lawn Care		All Around Town Outdoor Services		Lohman Earth Works		All Green Site Management		Mulchscapers LLC		Greg's Lawn and Landscaping	
				Total Price	\$15,000.00	Total Price	\$19,668.00	Total Price	\$24,750.00	Total Price	\$25,500.00	Total Price	\$27,000.00	Total Price	\$37,500.00
Line #	Description	QTY	UOM	Unit	Extended	Unit	Extended	Unit	Extended	Unit	Extended	Unit	Extended	Unit	Extended
1	Citywide Landscape Mulching	300	CY	\$ 50.00	\$15,000.00	\$ 65.56	\$ 19,668.00	\$ 82.50	\$ 24,750.00	\$ 85.00	\$ 25,500.00	\$ 90.00	\$ 27,000.00	\$ 125.00	\$ 37,500.00

Corrected

**FORM OF CONTRACT**

**THIS CONTRACT**, made the 3rd day of March A.D., 2026, by and between  
**MB Lawn Care, LLC**, hereinafter called the "Contractor", and  
the City of Bettendorf, Scott County, Iowa, hereinafter called the "City",

WITNESSETH, That the Contractor and the City for the consideration stated herein agree as follows:

**ARTICLE I. SCOPE OF WORK** - The Contractor shall perform everything required to be performed and shall provide and furnish all of the labor, necessary tools, expendable equipment, and transportation required to perform and complete in a workmanlike manner all the work required in connection with the **2026 Citywide Landscape Mulching Program**, all in strict accordance with the specifications, which are made a part of this contract; and in strict compliance with the Contractor's proposal and the other contract documents herein mentioned which are a part of this contract. The Contractor shall do everything required by this contract and the other documents constituting a part thereof.

**ARTICLE II. THE CONTRACT PRICE** - The City shall pay to the Contractor for the performance of this contract, subject to any additions or deductions provided therein, in current funds, the contract price of:

**Fifteen Thousand Dollars and 00/100 Cents**

computed as follows:

**Base Bid**

Item	Description	Quantity	Units	Unit Price	Total Price
1	Citywide Landscape Mulching	300	CY	\$50.00	\$15,000.00

**Total Base Bid: \$15,000.00**

**ARTICLE III. UNIT PRICES FOR CHANGES**- Not applicable to this contract.

**ARTICLE IV. PAYMENTS**- Payments are to be made to the Contractor in accordance with and subject to the provisions embodied in the documents made a part of this Contract.

**ARTICLE V. CONTRACT TIME-** Work under this contract shall commence on the date specified in the written Notice to Proceed from the City, or its authorized representative, to the Contractor who shall diligently prosecute and complete all work under this contract as outlined in the Special Conditions, weather depending.

**ARTICLE VII. COMPONENT PARTS OF THIS CONTRACT** - This contract consists of the following component parts, all of which are as fully a part of this contract as if herein set out verbatim, or, if not attached, as if hereto attached.

- 1) Special Conditions
- 2) Contract with the City
- 3) Request for Proposal
- 4) Contractor's Proposal

In the event that any provision in any of the foregoing component parts of this contract conflicts with any provision in any other of the component parts, the provision in the component part first enumerated shall govern over any other component part which follows it numerically, except as may be otherwise specifically stated.

IN WITNESS WHEREOF, the parties hereto have caused this Instrument to be executed in three original counterparts the date and year first above written.

MB Lawn Care, LLC

\_\_\_\_\_  
(Contractor)

By \_\_\_\_\_  
\_\_\_\_\_  
\_\_\_\_\_

(Title)

ATTEST:

\_\_\_\_\_  
\_\_\_\_\_  
\_\_\_\_\_  
(Title)

ATTEST:

CITY OF BETTENDORF, IA

\_\_\_\_\_  
Robert S. Gallagher  
Mayor

\_\_\_\_\_  
Decker P. Ploehn  
City Clerk

This Instrument approved by the City Council of the City of Bettendorf, Iowa, pursuant to Resolution Number \_\_\_\_\_ passed \_\_\_\_\_, 2026.

## COUNCIL LETTER

**MEETING DATE:** March 3, 2026  
**REQUESTED BY:** Brian Schmidt, P.E., Director of Public Works



---

### Item Title

Resolution awarding the contract to Delf's Landscaping & Irrigation for the 2026 Landscape Maintenance Services for the Learning Campus & Community Center.

### Explanation

This contract is to provide spring and fall cleanup, turf management, and landscape maintenance services for the Learning Campus (Bettendorf Family Museum and Library) and Community Center. This agreement will be for the 2026 growing season, with the option to extend up to an additional two (2) years.

Bids were received on February 24, 2026. Delf's Landscaping & Irrigation of Davenport, Iowa was the low bidder of five (5) bids received. Bids ranged from the high of \$126,257.50 to the low of \$40,595.00 for the cumulative total of all three (3) years. The low bid for 2026 is in the amount of \$13,300.00.

### **If the matter is not budgeted in the current year, explain why funding is requested and the anticipated source:**

This contract is funded within the Parks Maintenance operating budget (1001-0712-55081) with a total budget of \$230,000. This line item covers all beautification projects throughout the City. Pricing for all contracts this year has been very competitive and below budgeted amounts.

### List Attachments

Resolution, Bid Tabulation, and Contract.

**RESOLUTION NO. \_\_\_\_\_-26**

**RESOLUTION AWARDED THE CONTRACT TO DELF'S LANDSCAPING & IRRIGATION FOR THE  
2026 LANDSCAPE MAINTENANCE SERVICES FOR THE LEARNING CAMPUS & COMMUNITY  
CENTER**

WHEREAS, the City of Bettendorf issued a Request for Proposal to provide spring and fall cleanup, turf maintenance services (mowing, trimming, edging, and fertilizing/weed control) for the Learning Campus and Community Center; and

WHEREAS, bids were received for the 2026 Landscape Maintenance Services for the Learning Campus & Community Center on the 24<sup>th</sup> day of February, 2026; and

WHEREAS, five (5) bids were received and Delf's Landscaping & Irrigation of Davenport, Iowa was the low bidder in the amount of \$40,595.00 for the cumulative total of all three (3) years; and

WHEREAS, the low bid received from Delf's Landscape & Irrigation for 2026 is in the amount of \$13,300.00; and

WHEREAS, the Contractor has submitted a proposal that meets the specifications detailed in the above referenced Request for Proposal.

NOW, THEREFORE BE IT RESOLVED BY THE CITY COUNCIL OF THE CITY OF BETTENDORF, IOWA that the proposal from Delf's Landscaping & Irrigation be accepted, and the Mayor and City Administrator are hereby authorized and directed to sign the contract for execution of said project.

Passed, Approved and Adopted this 3<sup>rd</sup> day of March, 2026.

\_\_\_\_\_  
Robert S. Gallagher, Mayor

Attest:

\_\_\_\_\_  
Decker P. Ploehn, City Clerk

2026 Landscape Maintenance Service for Learning Campus & Community Center				Delfs Landscape & Irrigation		Fisher Lawn Care		Elite Property Maintenance		All Around Town Outdoor Services		Landmark LawnScapes, Inc.	
				Cumulitive Total	\$40,595.00	Cumulitive Total	\$59,700.00	Cumulitive Total	\$74,144.00	Cumulitive Total	\$103,433.33	Cumulitive Total	\$126,257.50
Line #	Description	QTY	UOM	Unit	Total Price	Unit	Total Price	Unit	Total Price	Unit	Total Price	Unit	Total Price
1	2026 Landscape Maintenance Services	1	LS	\$ 13,300.00	\$ 13,300.00	\$ 19,900.00	\$ 19,900.00	\$ 22,400.00	\$ 22,400.00	\$ 33,912.47	\$ 33,912.47	\$ 40,050.00	\$ 40,050.00
2	2027 Landscape Maintenance Services	1	LS	\$ 13,300.00	\$ 13,300.00	\$ 19,900.00	\$ 19,900.00	\$ 24,640.00	\$ 24,640.00	\$ 33,912.47	\$ 33,912.47	\$ 42,052.50	\$ 42,052.50
3	2028 Landscape Maintenance Services	1	LS	\$ 13,995.00	\$ 13,995.00	\$ 19,900.00	\$ 19,900.00	\$ 27,104.00	\$ 27,104.00	\$ 35,608.39	\$ 35,608.39	\$ 44,155.00	\$ 44,155.00

**FORM OF CONTRACT**

**THIS CONTRACT**, made the 3rd day of March A.D., 2026, by and between  
**Delf's Landscape & Irrigation** , hereinafter called the "Contractor", and  
the City of Bettendorf, Scott County, Iowa, hereinafter called the "City",

WITNESSETH, That the Contractor and the City for the consideration stated herein agree as follows:

**ARTICLE I. SCOPE OF WORK** - The Contractor shall perform everything required to be performed and shall provide and furnish all of the labor, necessary tools, expendable equipment, and transportation required to perform and complete in a workmanlike manner all the work required in connection with the **2026 Landscape Maintenance Services for the Learning Campus & Community Center**, all in strict accordance with the specifications, which are made a part of this contract; and in strict compliance with the Contractor's proposal and the other contract documents herein mentioned which are a part of this contract. The Contractor shall do everything required by this contract and the other documents constituting a part thereof.

**ARTICLE II. THE CONTRACT PRICE** - The City shall pay to the Contractor for the performance of this contract, subject to any additions or deductions provided therein, in current funds, the contract price of:

**Thirteen Thousand, Three Hundred Dollars and 00/100 Cents**

computed as follows:

**Base Bid**

Item	Description	Quantity	Units	Unit Price	Total Price
1	2026 Landscape Maintenance Services	1	LS	\$13,300.00	\$13,300.00

**2026 Total Base Bid: \$13,300.00**

**Additional Years**

Item	Description	Quantity	Units	Unit Price	Total Price
1	2027 Landscape Maintenance Services	1	LS	\$13,300.00	\$13,300.00

**2027 Total Base Bid: \$13,300.00**

**Additional Years**

Item	Description	Quantity	Units	Unit Price	Total Price
1	2027 Landscape Maintenance Services	1	LS	\$13,995.00	\$13,995.00

**2028 Total Base Bid: \$13,995.00**

**ARTICLE III. UNIT PRICES FOR CHANGES-** Not applicable to this contract.

**ARTICLE IV. PAYMENTS-** Payments are to be made to the Contractor in accordance with and subject to the provisions embodied in the documents made a part of this Contract.

**ARTICLE V. CONTRACT TIME-** Work under this contract shall commence on the date specified in the written Notice to Proceed from the City, or its authorized representative, to the Contractor who shall diligently prosecute and complete all work under this contract as outlined in the Special Conditions, weather depending.

**ARTICLE VII. COMPONENT PARTS OF THIS CONTRACT** - This contract consists of the following component parts, all of which are as fully a part of this contract as if herein set out verbatim, or, if not attached, as if hereto attached.

- 1) Special Conditions
- 2) Contract with the City
- 3) Request for Proposal
- 4) Contractor's Proposal

In the event that any provision in any of the foregoing component parts of this contract conflicts with any provision in any other of the component parts, the provision in the component part first enumerated shall govern over any other component part which follows it numerically, except as may be otherwise specifically stated.

IN WITNESS WHEREOF, the parties hereto have caused this Instrument to be executed in three original counterparts the date and year first above written.

\_\_\_\_\_  
Delf's Landscape & Irrigation  
(Contractor)

By \_\_\_\_\_

\_\_\_\_\_

\_\_\_\_\_  
(Title)

ATTEST:

\_\_\_\_\_

\_\_\_\_\_

\_\_\_\_\_  
(Title)

ATTEST:

CITY OF BETTENDORF, IA

\_\_\_\_\_  
Robert S. Gallagher  
Mayor

\_\_\_\_\_  
Decker P. Ploehn  
City Clerk

This Instrument approved by the City Council of the City of Bettendorf, Iowa, pursuant to Resolution Number \_\_\_\_\_ passed \_\_\_\_\_, 2026.

## COUNCIL LETTER

**MEETING DATE:** March 3, 2026  
**REQUESTED BY:** Brian Schmidt, P.E., Director of Public Works



---

### Item Title

Resolution awarding the contract to Lohman Earth Works for the 2026 Forest Grove Drive/Middle Road Corridor Landscape Maintenance Program.

### Explanation

This annual program is to provide spring and fall cleanup and landscape maintenance services within the medians and roundabouts along the Forest Grove Drive/Middle Road corridor for the 2026 growing season.

Bids were received on February 24, 2026. Lohman Earth Works of Davenport, Iowa was the low bidder of five (5) bids received. Bids ranged from the high of \$29,950.00 to the low of \$16,910.00.

### **If the matter is not budgeted in the current year, explain why funding is requested and the anticipated source:**

This contract is funded within the Parks Maintenance operating budget (1001-0712-55081) with a total budget of \$230,000. This line item covers all beautification projects throughout the City. Pricing for all contracts this year has been very competitive and below budgeted amounts.

### List Attachments

Resolution, Bid Tabulation, and Contract.

**RESOLUTION NO. \_\_\_\_\_-26**

**RESOLUTION AWARDING THE CONTRACT TO LOHMAN EARTH WORKS FOR THE  
2026 FOREST GROVE DRIVE/MIDDLE ROAD CORRIDOR LANDSCAPE MAINTENANCE  
PROGRAM**

WHEREAS, the City of Bettendorf issued a Request for Proposal for landscape maintenance services within the medians and round-a-bouts along the Forest Grove Drive/Middle Road corridor for the 2026 growing season; and

WHEREAS, bids were received for 2026 Forest Grove Drive/Middle Road Corridor Landscape Maintenance Program on the 24<sup>th</sup> day of February, 2026; and

WHEREAS, five (5) bids were received and Lohman Earth Works was the low bidder in the amount of \$16,910.00.

WHEREAS, the Contractor has submitted a proposal that meets the specifications detailed in the above referenced Request for Proposal.

NOW, THEREFORE BE IT RESOLVED BY THE CITY COUNCIL OF THE CITY OF BETTENDORF, IOWA that the proposal from Lohman Earth Works be accepted, and the Mayor and City Administrator are hereby authorized and directed to sign the contract for execution of said project.

Passed, Approved and Adopted this 3<sup>rd</sup> day of March, 2026.

---

Robert S. Gallagher, Mayor

Attest:

---

Decker P. Ploehn, City Clerk

**2026 Forest Grove Dr/Middle Rd Corridor  
Landscape Maintenance Program**

			Lohman Earth Works		All Green Site Management, LLC		Smith Seeding inc.		All Around Town Outdoor Services		Delfs Landscape & Irrigation											
			Total Price	\$16,910.00	Total Price	\$23,370.00	Total Price	\$28,968.00	Total Price	\$29,107.77	Total Price	\$29,950.00										
Line #	Description	QTY	Unit	Extended	Unit	Extended	Unit	Extended	Unit	Extended	Unit	Extended										
1	Forest Grove Dr./Middle Rd. Landscape Maintenance	1	\$	16,910.00	\$	16,910.00	\$	23,370.00	\$	23,370.00	\$	28,968.00	\$	28,968.00	\$	29,107.77	\$	29,107.77	\$	29,950.00	\$	29,950.00



**ARTICLE V. CONTRACT TIME**- Work under this contract shall commence on the date specified in the written Notice to Proceed from the City, or its authorized representative, to the Contractor who shall diligently prosecute and complete all work under this contract as outlined in the Special Conditions, weather depending.

**ARTICLE VII. COMPONENT PARTS OF THIS CONTRACT** - This contract consists of the following component parts, all of which are as fully a part of this contract as if herein set out verbatim, or, if not attached, as if hereto attached.

- 1) Special Conditions
- 2) Contract with the City
- 3) Request for Proposal
- 4) Contractor's Proposal

In the event that any provision in any of the foregoing component parts of this contract conflicts with any provision in any other of the component parts, the provision in the component part first enumerated shall govern over any other component part which follows it numerically, except as may be otherwise specifically stated.

IN WITNESS WHEREOF, the parties hereto have caused this Instrument to be executed in three original counterparts the date and year first above written.

Lohman Earth Works

\_\_\_\_\_  
(Contractor)

By \_\_\_\_\_

\_\_\_\_\_  
(Title)

ATTEST:

\_\_\_\_\_  
\_\_\_\_\_  
\_\_\_\_\_  
(Title)

ATTEST:

CITY OF BETTENDORF, IA

\_\_\_\_\_  
Robert S. Gallagher  
Mayor

\_\_\_\_\_  
Decker P. Ploehn  
City Clerk

This Instrument approved by the City Council of the City of Bettendorf, Iowa, pursuant to Resolution Number \_\_\_\_\_ passed \_\_\_\_\_, 2026.

## COUNCIL LETTER

**MEETING DATE:** March 3, 2026  
**REQUESTED BY:** Brian Schmidt, P.E., Director of Public Works



---

### Item Title

Resolution approving the contract extension for the Turf Maintenance Services Contract for City Right-of-Way (Zone 1- 2026).

### Explanation

This contract is to provide turf maintenance services (mowing, trimming, and edging) within City right-of-way and/or other locations. The original contract was awarded to A Cut Above Lawn and Landscape, LLC of Davenport Iowa for the 2024 growing season with the option to extend the contract for two (2) years. Staff is requesting to extend turf maintenance services through the 2026 growing season for a total of \$29,790.00.

### If the matter is not budgeted in the current year, explain why funding is requested and the anticipated source:

This contract is funded within the Parks Maintenance operating budget (2060-0708-55081) with a total budget of \$110,000 in the current fiscal year. This line item covers all mowing and landscaping maintenance within the right-of-way throughout the City. Pricing for all contracts this year are below budgeted amounts.

### List Attachments

Resolution

**RESOLUTION NO. \_\_\_\_\_-26**

**RESOLUTION APPROVING THE CONTRACT EXTENSION FOR THE TURF MAINTENANCE SERVICES CONTRACT FOR CITY RIGHT-OF-WAY (ZONE 1- 2026)**

WHEREAS, on the 5<sup>th</sup> day of March 2024 the City of Bettendorf awarded a contract to A Cut Above Lawn and Landscape, LLC for turf maintenance services (mowing, trimming, and edging) within City right-of-way and/or other locations, and

WHEREAS, the original contract provided the option of two (2) one (1) year contract extensions, and

WHEREAS, staff is requesting to extend the turf maintenance services contract for the 2026 growing season in the amount of \$29,790.00.

NOW, THEREFORE BE IT RESOLVED BY THE CITY COUNCIL OF THE CITY OF BETTENDORF, IOWA that the contract extension for the Turf Maintenance Services for City Right-of-Way (Zone 1-2026) is approved, and the Director of Public Works is hereby authorized to issue a purchase order to A Cut Above Lawn and Landscape, LLC in the amount of \$29,790.00.

Passed, Approved and Adopted this 3<sup>rd</sup> day of March, 2026.

---

Robert S. Gallagher, Mayor

Attest:

---

Decker P. Ploehn, City Clerk

## COUNCIL LETTER

**MEETING DATE:** March 3, 2026  
**REQUESTED BY:** Brian Schmidt, P.E., Director of Public Works



---

### Item Title

Resolution approving the contract extension for the Turf Maintenance Services Contract for City Right-of-Way (Zone 2- 2026).

### Explanation

This contract is to provide turf maintenance services (mowing, trimming, and edging) within City right-of-way and/or other locations. The original contract was awarded to A Cut Above Lawn and Landscape, LLC of Davenport Iowa for the 2024 growing season with the option to extend the contract for two (2) years. Staff is requesting to extend services through the 2026 growing season for a total of \$37,470.00.

### If the matter is not budgeted in the current year, explain why funding is requested and the anticipated source:

This contract is funded within the Parks Maintenance operating budget (2060-0708-55081) with a total budget of \$110,000 in the current fiscal year. This line item covers all mowing and landscaping maintenance within the right-of-way throughout the City. Pricing for all contracts this year are below budgeted amounts.

### List Attachments

Resolution

**RESOLUTION NO. \_\_\_\_\_-26**

**RESOLUTION APPROVING THE CONTRACT EXTENSION FOR THE TURF MAINTENANCE SERVICES CONTRACT FOR CITY RIGHT-OF-WAY (ZONE 2- 2026)**

WHEREAS, on the 5<sup>th</sup> day of March 2024 the City of Bettendorf awarded a contract to A Cut Above Lawn and Landscape, LLC for turf maintenance services (mowing, trimming, and edging) within City right-of-way and/or other locations, and

WHEREAS, the original contract provided the option of two (2) one (1) year contract extensions, and

WHEREAS, staff is requesting to extend the turf maintenance services contract for the 2026 growing season in the amount of \$37,470.00.

NOW, THEREFORE BE IT RESOLVED BY THE CITY COUNCIL OF THE CITY OF BETTENDORF, IOWA that the contract extension for the Turf Maintenance Services for City Right-of-Way (Zone 2-2026) is approved, and the Director of Public Works is hereby authorized to issue a purchase order to A Cut Above Lawn and Landscape, LLC in the amount of \$37,470.00.

Passed, Approved and Adopted this 3<sup>rd</sup> day of March, 2026.

---

Robert S. Gallagher, Mayor

Attest:

---

Decker P. Ploehn, City Clerk

## COUNCIL LETTER

**MEETING DATE:** March 3, 2026  
**REQUESTED BY:** Brian Schmidt, P.E., Director of Public Works



---

### Item Title

Resolution approving the contract extension for the Downtown Landscape Planting and Maintenance Program.

### Explanation

This contract is to provide various landscape planting, mulching and maintenance services at City Hall and in the downtown area, as well as mowing and turf maintenance at other City facilities nearby. The original contract was awarded to Corn Crib Nursery of Coal Valley, IL for the 2025 growing season with the option to extend the contract up to an additional two (2) years. Staff is requesting to extend services through the 2026 growing season. The bid for 2026 is in the amount of \$63, 318.00.

### If the matter is not budgeted in the current year, explain why funding is requested and the anticipated source:

This contract is funded within the Parks Maintenance operating budget (1001-0712-55081) with a total budget of \$230,000 in the current fiscal year. This line item covers all beautification projects throughout the City. Of that \$230,000, \$80,000 was budgeted for this specific program. Staff is requesting a contingency of the full budget amount be awarded to cover miscellaneous repairs and additional services that may arise after the winter months, such as the replacement of any dead plant material or repairs due to snow removal.

### List Attachments

Resolution

**RESOLUTION NO. \_\_\_\_\_-26**

**RESOLUTION APPROVING THE CONTRACT EXTENSION FOR THE DOWNTOWN LANDSCAPE  
PLANTING AND MAINTENANCE PROGRAM**

WHEREAS, on the 1<sup>st</sup> day of April 2025 the City of Bettendorf awarded a contract to Corn Crib Nursery to provide various landscape planting, mulching and maintenance services at City Hall and in the downtown area, as well as mowing and turf maintenance at other City facilities nearby; and

WHEREAS, the original contract provided the option of two (2) one (1) year contract extensions; and

WHEREAS, staff is requesting to extend the Downtown Landscape Planting and Maintenance Program contract for the 2026 growing season in the amount of \$63,318.00.

NOW, THEREFORE BE IT RESOLVED BY THE CITY COUNCIL OF THE CITY OF BETTENDORF, IOWA that the contract extension for the Downtown Landscape Planting and Maintenance Program is approved, and the Director of Public Works is hereby authorized to issue a purchase order to Corn Crib Nursery in the amount of \$80,000.00 including the contingency.

Passed, Approved and Adopted this 3<sup>rd</sup> day of March, 2026.

---

Robert S. Gallagher, Mayor

Attest:

---

Decker P. Ploehn, City Clerk

## COUNCIL LETTER

**MEETING DATE:** March 3, 2026 (SPH)  
March 17, 2026 (HPH)

**REQUESTED BY:** Chris Curran, City Attorney



---

### Item Title

Resolution setting the date for a public hearing for request for designation as Forest Covers/Rivers and Streams/River and Stream Banks for a portion of property located at 4340 Tanglewood Road to qualify for tax exemption.

### Explanation

The Council has approved a policy on land set aside for conservation purposes. Chad Miller requests property he owns receive that designation. Pursuant to the policy, the council is asked to set a public hearing on the matter and send notice to adjacent property owners.

If approved, tax revenues from the property so designated will end.

### **If the matter is not budgeted in the current year, explain why funding is requested and the anticipated source:**

N/A

### List Attachments

- Resolution (SPH)
- Notice of Public Hearing
- Resolution (HPH)
- Letter from Scott County
- Application
- Aerial Photo
- Policy

**RESOLUTION SETTING THE DATE FOR A PUBLIC HEARING FOR  
REQUEST FOR DESIGNATION AS FOREST COVERS/ RIVERS AND  
STREAMS/ RIVER AND STREAM BANKS FOR A PORTION OF PROPERTY  
LOCATED AT 4340 TANGLEWOOD ROAD  
TO QUALIFY FOR TAX EXEMPTION**

**BE IT RESOLVED** by the City Council of the City of Bettendorf, Iowa, that a public hearing be set for 17<sup>th</sup> day of March, 2026, at 7:00 p.m. in the Council Chambers at City Hall, 1609 State Street, Bettendorf, to receive public comment on the request of the property owner at 4340 Tanglewood Road to classify a portion of property he owns within the city as forest covers/ rivers and streams/river and stream banks and qualify as tax exempt under Iowa Code Section 427.1(22).

**BE IT FURTHER RESOLVED** that the City Clerk is directed to mail notice of this request to all property owners within 200 feet of the subject property, as well as to the property owner, Chad Miller.

**PASSED, APPROVED AND ADOPTED** this 3<sup>rd</sup> day of March, 2026.

---

Robert S. Gallagher, Mayor

ATTEST:

---

Decker P. Ploehn, City Clerk

## **NOTICE OF PUBLIC HEARING**

### **To Whom It May Concern:**

Notice is hereby given that on the 17th day of March, 2026, at 7:00 p.m., the City Council of the City of Bettendorf, Iowa, will conduct a public hearing at City Hall, Council Chambers, 1609 State Street, regarding the request of the property owner(s) at 4340 Tanglewood Road to classify a portion of property they own within the city as Forest Covers/River and Streams/River and Stream Banks, and qualify as tax exempt.

The City Council has set said hearing at the time and place specified. Written suggestions or objections concerning this issue may be filed with the City Clerk at or before such hearing and will be heard by the City Council at the time and place specified.

Interested persons desiring to present their views upon the issue, either in writing or verbally, will be given the opportunity to be heard at the above mentioned time and place.

Dated at Bettendorf, Iowa, this 3rd day of March, 2026

Decker P. Ploehn, City Administrator

**APPROVING REQUEST FOR TAX EXEMPTION FOR  
4340 TANGLEWOOD ROAD**

**WHEREAS**, the owner of property located at 4340 Tanglewood Road has requested to have a portion of his property designated as tax exempt under Iowa Code Section 427.1(22) as Forest Covers/Rivers and Streams/River and Stream Banks; and

**WHEREAS**, pursuant to policy adopted by the City Council, the Council has held a public hearing on the request, and considered the comments of adjoining properties, if any.

**NOW, THEREFORE, BE IT RESOLVED** by the City Council of the City of Bettendorf, Iowa, said request is hereby approved.

**PASSED, APPROVED AND ADOPTED** this 17<sup>th</sup> day of March, 2026.

---

Robert S. Gallagher, Mayor

**ATTEST:**

---

Decker P. Ploehn, City Clerk

**OFFICE OF THE COUNTY ASSESSOR**

600 West 4<sup>th</sup> Street  
Davenport, Iowa 52801-1030  
Office: (563) 326-8635  
[www.scottcountyiowa.gov](http://www.scottcountyiowa.gov)  
[assessor@scottcountyiowa.gov](mailto:assessor@scottcountyiowa.gov)



---

TOM MCMANUS  
County Assessor

JOHN KELLY  
Deputy Assessor

February 18, 2026

**To:** Mahesh Sharma, Scott County Administrator

**From:** Tom R. McManus

**RE:** 2026 Slough Bill Applications

Enclosed is a list of the 2026 Slough Bill Tax Exemption applicants received from the Scott County Soil & Water Conservation District for the Board of Supervisors' approval. The City of Bettendorf will approve the applications within its jurisdiction. The total number of acres recommended for approval is 1,234.272, with a land value of \$1,697,900 in the rural area. The City of Davenport applications have been forwarded to the City of Davenport Assessor's Office.

If you need any additional information, please contact me or Amber Johnson at ext. 3218.

Thank you,  
Tom R. McManus  
Scott County Assessor

# Scott County Soil & Water Conservation District

8370 Hillandale Road, Davenport, Iowa 52806

Phone 563-391-1403 ext. 3 Fax 563-388-0682

Chad Dexter Lora Schmidt Joshua Witt Christine Bolte Tracey Kuehl



Soil & Water  
Conservation District

February 4<sup>th</sup>, 2026

Scott County Assessor  
600 W. 4<sup>th</sup> Street  
Davenport, IA 52801

Enclosed are this year's Natural Conservation or Wildlife Area Property Tax Exemption applications. The Scott County SWCD Commissioners have approved these applications as meeting the criteria for the stated exemption.

## Renewals

	Marianne Hamilton ✓	Forest Cover	18.10 acres
<del>DAVENPORT</del>	Shirley Perry	Open Prairie	5.0 acres
<del>DAVENPORT</del>	Dean Krueger	Open Prairie	22.51 acres
<del>DAVENPORT</del>	Genesis Systems Group LLC	Forest Cover	25.80 acres
	Haase Living Trust ✓	Open Prairie	7.0 acres
<del>DAVENPORT</del>	Burton Voss Trust	Forest Cover	5.602 acres
<del>DAVENPORT</del>	Brian Ritter	Forest Cover	57.59 acres
	Lawrence & Tara Youngers Rev Trust ✓	Forest Cover	3.80 acres
<del>DAVENPORT</del>	Plumb Supply Co LLC	Open Prairie	6.016 acres
	Jon Hilmann ✓	Forest Cover	2.4 acres
<del>DAVENPORT</del>	David Bierl	Forest Cover	15.0 acres
	Robert Kolwey ✓	Open Prairie	2.3 acres
	Richard Mohr ✓	Forest Cover	5.65 acres
	Charles Beason ✓	Forest Cover	22.98 acres
	Douglas Vickstrom Rev Trust ✓	Forest Cover	12.02 acres
	Greg Hawk ✓	Open Prairie	2.636 acres
	Tobin Living Trust ✓	Forest Cover	4.01 acres
<del>DETENDORF</del>	Judith A Tully Rev Trust ✓	Open Prairie	658.34 acres
	Ryan Living Trust ✓	Forest Cover	19.0 acres
	Michael Purcell ✓	Forest Cover	125.0 acres
	STL Properties LLC ✓	Forest Cover	10.7 acres
	Terry Rathje ✓	Forest Cover	5.0 acres
	Donald Kreiter ✓	Open Prairie	5.5 acres
	JC Davis Jr ✓	Forest Cover	3.1 acres
<del>DAVENPORT</del>	John Carrillo	Open Prairie	71.9 acres
		Open Prairie	4.2 acres
		Open Prairie	10.7 acres
		Rec Lake	1.3 acres
		Forest Cover	17.45 acres
		Open Prairie	6.6 acres

# Scott County Soil & Water Conservation District

8370 Hillandale Road, Davenport, Iowa 52806

Phone 563-391-1403 ext. 3 Fax 563-388-0682

Chad Dexter Lora Schmidt Joshua Witt Christine Bolte Tracey Kuehl

Anthony & Carrie Crossen ✓	Forest Cover	7.5 acres
Mark Wagemester (NEW FOR 2024)	River & Streambanks	3.94 acres
Alan & Nancy Henningsen ✓	Open Prairie	66.2 acres
	Forest Cover	59.3 acres
Andrew Claeys ✓	Forest Cover	17.31 acres
Andrew Strunk ✓	Forest Cover	2.0 acres
Kim Strunk ✓	Open Prairie	5.0 acres
LETTENDLE Gary & Elizabeth Fincher (NEW FOR 2024)	Forest Cover	10.7 acres
Brad Moeller ✓	Open Prairie	50.0 acres
	Forest Cover	16.48 acres
DAVENPORT CWC Series LLC Series D	Forest Cover	24.4 acres
Tony Singh (PRAIRIE DAKES)	Open Prairie	6.6 acres
LETTENDLE Chad A Miller Rev Trust	Forest Cover	2.0 acres
	River & Streambanks	2.3 acres
Ben Taylor (NEW FOR 2024)	Forest Cover	3.4 acres
DAVENPORT Senior Star Investments LLC	River & Streambanks	8.96 acres
	+ Open Prairie	
	+ Forest Cover	

## New

\*\*MBM Investments LLC (NEW FOR 2024) Open Prairie 3.25 acres

\*\*Parcel previously applied for under Jane Morrell

Please contact me if you have any questions.

Sincerely,

Rowan O.K. Kuechenmeister  
Conservation Assistant



IOWA DEPARTMENT OF  
AGRICULTURE &  
LAND STEWARDSHIP

Scott County Soil & Water Conservation District

8370 Hillandale Rd, Davenport IA 52806

563.391.1403 ext.3

[rowan.kuechenmeister@ia.nacdnet.net](mailto:rowan.kuechenmeister@ia.nacdnet.net)



Natural Conservation or Wildlife Areas  
Property Tax Exemption

Iowa Code section 427.1(22)

This application must be filed or postmarked to your local soil and water conservation district on or before February 1 of each year. However, the exemption for the owner of property described under Iowa Code section 427.1(22)(g) shall continue from year to year without additional application as long as the property qualifies and is not used for economic gain. Iowa conservation district addresses can be found at the Conservation Districts of Iowa website: [cdiowa.org](http://cdiowa.org).

Print property information

Parcel number: 8414172032

Owner: Chad A Miller Revoc. Trust

Property location address: 4340 Tanglewood Rd.

City: Bettendorf State: Ia ZIP: 52722

Property owner mailing address: 4340 Tanglewood Rd.

City: Bettendorf State: IA ZIP: 52722

County: Scott Number of acres: 4.30

Phone: (563) 349-8692 Email: TaxExApp@millerwrks.com

Print applicant information if other than owner

Name: Chad A. Miller

Applicant mailing address: 4340 Tanglewood Rd.

City: Bettendorf State: IA ZIP: 52722

Phone: (563) 349-8692 Email: TaxExApp@millerwrks.com

Relationship to owner: Owner

Property type:

- Recreational lakes
- Rivers and streams
- Forest covers
- Open prairies
- River and stream banks
- Section 427.1(22)(g) property

An aerial photo of the property on which the property to be exempted is outlined:

Is included:  Is on file with the assessor:

If the property is a gully area susceptible to erosion, an erosion control map approved by the soil and conservation district commissioners: Is included  Is on file with the assessor

I, Chad Miller swear or affirm that the above property will not be used for economic gain of any kind during the assessment year. I declare under penalties of perjury or false certificate, that I have examined this application, and, to the best of my knowledge, it is true, correct, and complete.

Applicant signature: Chad Miller Date: 01-21-2026





# Scott County / City of Davenport, Iowa



## Overview

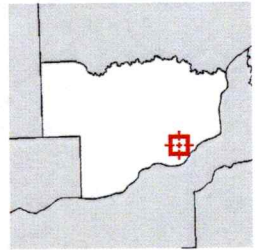

## Legend

- Political Township
- Corporate Limits
- County Boundary
- Railroad
- All Roads**
- Interstate
- US Highway
- State Highway
- County Route
- Major road
- Local roads
- Ramp
- Alleyway/Access Road
- Bike/Pedestrian Trail
- Driveway
- Rights of Way
- Major Rivers and Streams**
- River Centerline
- River Boundary
- Major Stream
- Minor Streams, Other**
- Minor Stream
- Small Lake/Pond
- Drainageways, etc
- Island
- Major Rivers and Lakes**
- Lake
- Major Stream
- River
- Minor Lakes and Ponds
- Parcels
- Parcel Point

**MORE SPECIFICALLY:**

**Slough Bill Application Area**

Date: 1/15/2020

Customer(s): CHAD A MILLER  
District: SCOTT SOIL & WATER CONSERVATION DISTRICT

Field Office: DAVENPORT SERVICE CENTER  
Agency: USDA-NRCS  
Assisted By: J. Bisinger

Legal Description: **4.3 AC**



**Legend**

- forest\_cover ~~1.6 ac~~ **2.0 AC**
- slough-stream & stream banks 2.3 ac
- Consplan-t4894
- Iowa - Counties
- Scott Co - Townships

Prepared with assistance from USDA-Natural Resources Conservation Service



## **POLICY ON APPROVAL OF TAX EXEMPTIONS FOR NATURAL CONSERVATION AND WILDLIFE AREAS**

**WHEREAS**, the Iowa Code Section 427.1 allows certain real estate to be maintained in tax exempt status when certain conditions are met; and

**WHEREAS**, for areas to be designated natural conversation and wildlife areas before such status can be approved within a city, city council permission must be granted; and

**WHEREAS**, the adoption of a policy on the consideration of such requests will help guide the Council in its decision making.

### **NOW THEREFORE UPON REQUEST BY THE COUNTY BOARD OF SUPERVISORS TO CONSIDER A TAX EXEMPTION REQUEST, THE COUNCIL SHALL:**

1. Mail notice to all property holders within 200 feet of the parcel under consideration of the request to designate the ground as natural conservation and wildlife area, and invite written or oral comment at the designated council meeting.
2. Request the applicant to come before the Council, to show the area being requested for tax exempt status, explain what actions the applicant has taken in order to establish the area as natural conservation or wildlife area, how long the application expects the ground to remain in that status, and the expected property tax saving associated with the designation.
3. The Council may approve, approve with conditions, or deny the application. In the event the applicant does not follow the conditions, the application shall be deemed to be denied.
4. The City Administrator shall notify the County Board of Supervisors of the decision of the Council.

### **FACTORS TO CONSIDER IN DETERMINING WHETHER THE COUNCIL SHALL APPROVE A REQUEST:**

- The size of the parcel to be designated as natural conservation or wildlife area;
- The area's suitability for other use; that is, in the absence of the property tax abatement, would the ground likely develop or be used for other purpose;
- The amount of public access that will be available for the parcel;
- The impact of the proposal on surrounding property;
- The amount of tax revenue which will be lost by virtue of the approval of the request;
- The length of time the parcel is expected to remain as a nature conservation/wildlife area;
- The impact or potential impact the designation would have on benefiting environmental concerns such as storm water runoff, water quality, air quality, and the preservation or enhancement of native plant species; and
- The impact or potential impact the designation would have on benefiting wildlife habitat.

## COUNCIL LETTER

**MEETING DATE:** March 3, 2026 (SPH)  
March 17, 2026 (HPH)

**REQUESTED BY:** Chris Curran, City Attorney



---

### Item Title

Resolution setting the date for a public hearing for request for designation as Forest Covers for a portion of property located at 3000 Barcelona Terrace to qualify for tax exemption.

### Explanation

The Council has approved a policy on land set aside for conservation purposes. Judith Tully requests property she owns receive that designation. Pursuant to the policy, the council is asked to set a public hearing on the matter and send notice to adjacent property owners.

If approved, tax revenues from the property so designated will end.

### If the matter is not budgeted in the current year, explain why funding is requested and the anticipated source:

N/A

### List Attachments

- Resolution (SPH)
- Notice of Public Hearing
- Resolution (HPH)
- Letter from Scott County
- Application
- Aerial Photo
- Policy

**RESOLUTION SETTING THE DATE FOR A PUBLIC HEARING FOR  
REQUEST FOR DESIGNATION AS FOREST COVERS FOR A PORTION OF  
PROPERTY LOCATED AT 3000 BARCELONA TERRACE  
TO QUALIFY FOR TAX EXEMPTION**

**BE IT RESOLVED** by the City Council of the City of Bettendorf, Iowa, that a public hearing be set for 17<sup>th</sup> day of March, 2026, at 7:00 p.m. in the Council Chambers at City Hall, 1609 State Street, Bettendorf, to receive public comment on the request of the property owner at 3000 Barcelona Terrace to classify a portion of property she owns within the city as forest covers qualify as tax exempt under Iowa Code Section 427.1(22).

**BE IT FURTHER RESOLVED** that the City Clerk is directed to mail notice of this request to all property owners within 200 feet of the subject property, as well as to the property owner, Judith Tully.

**PASSED, APPROVED AND ADOPTED** this 3<sup>rd</sup> day of March, 2026.

---

Robert S. Gallagher, Mayor

ATTEST:

---

Decker P. Ploehn, City Clerk

## **NOTICE OF PUBLIC HEARING**

### **To Whom It May Concern:**

Notice is hereby given that on the 17th day of March, 2026, at 7:00 p.m., the City Council of the City of Bettendorf, Iowa, will conduct a public hearing at City Hall, Council Chambers, 1609 State Street, regarding the request of the property owner(s) at 3000 Barcelona Terrace to classify a portion of property they own within the city as Forest Covers, and qualify as tax exempt.

The City Council has set said hearing at the time and place specified. Written suggestions or objections concerning this issue may be filed with the City Clerk at or before such hearing and will be heard by the City Council at the time and place specified.

Interested persons desiring to present their views upon the issue, either in writing or verbally, will be given the opportunity to be heard at the above mentioned time and place.

Dated at Bettendorf, Iowa, this 3rd day of March, 2026

Decker P. Ploehn, City Administrator

**APPROVING REQUEST FOR TAX EXEMPTION FOR  
3000 BARCELONA TERRACE**

**WHEREAS**, the owner of property located at 3000 Barcelona Terrace has requested to have a portion of her property designated as tax exempt under Iowa Code Section 427.1(22) as Forest Covers; and

**WHEREAS**, pursuant to policy adopted by the City Council, the Council has held a public hearing on the request, and considered the comments of adjoining properties, if any.

**NOW, THEREFORE, BE IT RESOLVED** by the City Council of the City of Bettendorf, Iowa, said request is hereby approved.

**PASSED, APPROVED AND ADOPTED** this 17<sup>th</sup> day of March, 2026.

\_\_\_\_\_  
Robert S. Gallagher, Mayor

**ATTEST:**

\_\_\_\_\_  
Decker P. Ploehn, City Clerk

**OFFICE OF THE COUNTY ASSESSOR**

600 West 4<sup>th</sup> Street

Davenport, Iowa 52801-1030

Office: (563) 326-8635

[www.scottcountyia.gov](http://www.scottcountyia.gov)

[assessor@scottcountyia.gov](mailto:assessor@scottcountyia.gov)



---

TOM MCMANUS  
County Assessor

JOHN KELLY  
Deputy Assessor

February 18, 2026

**To:** Mahesh Sharma, Scott County Administrator

**From:** Tom R. McManus

**RE:** 2026 Slough Bill Applications

Enclosed is a list of the 2026 Slough Bill Tax Exemption applicants received from the Scott County Soil & Water Conservation District for the Board of Supervisors' approval. The City of Bettendorf will approve the applications within its jurisdiction. The total number of acres recommended for approval is 1,234.272, with a land value of \$1,697,900 in the rural area. The City of Davenport applications have been forwarded to the City of Davenport Assessor's Office.

If you need any additional information, please contact me or Amber Johnson at ext. 3218.

Thank you,  
Tom R. McManus  
Scott County Assessor

# Scott County Soil & Water Conservation District

8370 Hillandale Road, Davenport, Iowa 52806

Phone 563-391-1403 ext. 3 Fax 563-388-0682

Chad Dexter Lora Schmidt Joshua Witt Christine Bolte Tracey Kuehl



Soil & Water  
Conservation District

February 4<sup>th</sup>, 2026

Scott County Assessor  
600 W. 4<sup>th</sup> Street  
Davenport, IA 52801

Enclosed are this year's Natural Conservation or Wildlife Area Property Tax Exemption applications. The Scott County SWCD Commissioners have approved these applications as meeting the criteria for the stated exemption.

## Renewals

	Marianne Hamilton ✓	Forest Cover	18.10 acres
<del>DAVENPORT</del>	Shirley Perry	Open Prairie	5.0 acres
<del>DAVENPORT</del>	Dean Krueger	Open Prairie	22.51 acres
<del>DAVENPORT</del>	Genesis Systems Group LLC	Forest Cover	25.80 acres
	Haase Living Trust ✓	Open Prairie	7.0 acres
<del>DAVENPORT</del>	Burton Voss Trust	Forest Cover	5.602 acres
<del>DAVENPORT</del>	Brian Ritter	Forest Cover	57.59 acres
	Lawrence & Tara Youngers Rev Trust ✓	Forest Cover	3.80 acres
<del>DAVENPORT</del>	Plumb Supply Co LLC	Open Prairie	6.016 acres
	Jon Hilmann ✓	Forest Cover	2.4 acres
<del>DAVENPORT</del>	David Bierl	Forest Cover	15.0 acres
	Robert Kolwey ✓	Open Prairie	2.3 acres
	Richard Mohr ✓	Forest Cover	5.65 acres
	Charles Beason ✓	Forest Cover	22.98 acres
	Douglas Vickstrom Rev Trust ✓	Forest Cover	12.02 acres
	Greg Hawk ✓	Open Prairie	2.636 acres
	Tobin Living Trust ✓	Forest Cover	4.01 acres
<del>DETENDORF</del>	Judith A Tully Rev Trust ✓	Open Prairie	658.34 acres
	Ryan Living Trust ✓	Forest Cover	19.0 acres
	Michael Purcell ✓	Forest Cover	125.0 acres
	STL Properties LLC ✓	Forest Cover	10.7 acres
	Terry Rathje ✓	Forest Cover	5.0 acres
	Donald Kreiter ✓	Open Prairie	5.5 acres
	JC Davis Jr ✓	Forest Cover	3.1 acres
<del>DAVENPORT</del>	John Carrillo	Open Prairie	71.9 acres
		Open Prairie	4.2 acres
		Open Prairie	10.7 acres
		Rec Lake	1.3 acres
		Forest Cover	17.45 acres
		Open Prairie	6.6 acres

# Scott County Soil & Water Conservation District

8370 Hillandale Road, Davenport, Iowa 52806

Phone 563-391-1403 ext. 3 Fax 563-388-0682

Chad Dexter Lora Schmidt Joshua Witt Christine Bolte Tracey Kuehl

Anthony & Carrie Crossen ✓	Forest Cover	7.5 acres
Mark Wagemester (NEW FOR 2024)	River & Streambanks	3.94 acres
Alan & Nancy Henningsen ✓	Open Prairie	66.2 acres
	Forest Cover	59.3 acres
Andrew Claeys ✓	Forest Cover	17.31 acres
Andrew Strunk ✓	Forest Cover	2.0 acres
Kim Strunk ✓	Open Prairie	5.0 acres
LETTENDLE Gary & Elizabeth Fincher (NEW FOR 2024)	Forest Cover	10.7 acres
Brad Moeller ✓	Open Prairie	50.0 acres
	Forest Cover	16.48 acres
DAVENPORT CWC Series LLC Series D	Forest Cover	24.4 acres
Tony Singh (PRAIRIE DAKA)	Open Prairie	6.6 acres
LETTENDLE Chad A Miller Rev Trust	Forest Cover	2.0 acres
	River & Streambanks	2.3 acres
Ben Taylor (NEW FOR 2024)	Forest Cover	3.4 acres
DAVENPORT Senior Star Investments LLC	River & Streambanks	8.96 acres
	+ Open Prairie	
	+ Forest Cover	

## New

\*\*MBM Investments LLC (NEW FOR 2024) Open Prairie 3.25 acres

\*\*Parcel previously applied for under Jane Morrell

Please contact me if you have any questions.

Sincerely,

Rowan O.K. Kuechenmeister  
Conservation Assistant



IOWA DEPARTMENT OF  
AGRICULTURE &  
LAND STEWARDSHIP

Scott County Soil & Water Conservation District

8370 Hillandale Rd, Davenport IA 52806

563.391.1403 ext.3

[rowan.kuechenmeister@ia.nacdnet.net](mailto:rowan.kuechenmeister@ia.nacdnet.net)



Natural Conservation or Wildlife Areas
Property Tax Exemption

Iowa Code section 427.1(22)

This application must be filed or postmarked to your local soil and water conservation district on or before February 1 of each year. However, the exemption for the owner of property described under Iowa Code section 427.1(22)(g) shall continue from year to year without additional application as long as the property qualifies and is not used for economic gain. Iowa conservation district addresses can be found at the Conservation Districts of Iowa website: cdiowa.org.

Print property information

Parcel number: 841017204 (forest cover)
Owner: Judith A Tully Revocable Trust (Jim & Judy Tully)
Property location address: 3000 Barcelona Terrace
City: Bettendorf State: IA ZIP: 52722
Property owner mailing address: 3000 Barcelona Terrace
City: Bettendorf State: IA ZIP: 52722
County: Scott Number of acres: 10.70
Phone: (563) 332-5585 Email:

Print applicant information if other than owner

Name:
Applicant mailing address:
City: State: ZIP:
Phone: Email:
Relationship to owner:

Property type:

- Recreational lakes [ ] Rivers and streams [ ] Forest covers [x]
Open prairies [ ] River and stream banks [ ] Section 427.1(22)(g) property [ ]

An aerial photo of the property on which the property to be exempted is outlined:

Is included: [ ] Is on file with the assessor: [x]

If the property is a gully area susceptible to erosion, an erosion control map approved by the soil and conservation district commissioners: Is included [ ] Is on file with the assessor [ ]

I, Judith Tully, swear or affirm that the above property will not be used for economic gain of any kind during the assessment year. I declare under penalties of perjury or false certificate, that I have examined this application, and, to the best of my knowledge, it is true, correct, and complete.

Applicant signature: Judith Tully Date: 11-25-2

OFFICE USE ONLY

I hereby certify that the property described above is eligible to receive the exemption claimed.

Signed: \_\_\_\_\_ Date: 2-4-26

Chairman, Scott County Soil and Water Conservation District

This open prairie property has been inspected and certified as having adequate ground cover consisting of native species, and that all primary and secondary noxious weeds present are being controlled to prevent the spread of seeds by either wind or water.

Signed: \_\_\_\_\_ Date: \_\_\_\_\_

Chairman, \_\_\_\_\_ County Board of Supervisors



### Overview



### Legend

- Political Township
- Corporate Limits
- County Boundary
- Railroad
- All Roads**
- Interstate
- US Highway
- State Highway
- County Route
- Major road
- Local roads
- Ramp
- Alleyway/Access Road
- Bike/Pedestrian Trail
- Driveway
- Rights of Way
- Major Rivers and Streams**
- River Centerline
- River Boundary
- Major Stream
- Minor Streams, Other**
- Minor Stream
- Small Lake/Pond
- Drainageways, etc
- Island
- Major Rivers and Lakes**
- Lake
- Major Stream
- River
- Minor Lakes and Ponds**
- Pond
- Parcels
- ♦ Parcel Point

<b>Parcel ID</b>	841017204	<b>Alternate ID</b>	n/a	<b>Owner Address</b>	JUDITH A TULLY REVOCABLE TRUST
<b>Sec/Twp/Rng</b>	n/a	<b>Class</b>	R		3000 BARCELONA TR
<b>Property Address</b>	3000 BARCELONA TR BETTENDORF	<b>Acreage</b>	15.6		BETTENDORF IA 52722
<b>District</b>	BEP	<b>Graphic Acres</b>	14.945		
<b>Brief Tax Description</b>	FRANK MARTZAHN Lot: 004 FRANK MARTZAHNAUDITOR'S PLAT (Note: Not to be used on legal documents)				

Date created: 2/13/2024  
Last Data Uploaded: 2/13/2024 11:13:34 AM

## **POLICY ON APPROVAL OF TAX EXEMPTIONS FOR NATURAL CONSERVATION AND WILDLIFE AREAS**

**WHEREAS**, the Iowa Code Section 427.1 allows certain real estate to be maintained in tax exempt status when certain conditions are met; and

**WHEREAS**, for areas to be designated natural conversation and wildlife areas before such status can be approved within a city, city council permission must be granted; and

**WHEREAS**, the adoption of a policy on the consideration of such requests will help guide the Council in its decision making.

### **NOW THEREFORE UPON REQUEST BY THE COUNTY BOARD OF SUPERVISORS TO CONSIDER A TAX EXEMPTION REQUEST, THE COUNCIL SHALL:**

1. Mail notice to all property holders within 200 feet of the parcel under consideration of the request to designate the ground as natural conservation and wildlife area, and invite written or oral comment at the designated council meeting.
2. Request the applicant to come before the Council, to show the area being requested for tax exempt status, explain what actions the applicant has taken in order to establish the area as natural conservation or wildlife area, how long the application expects the ground to remain in that status, and the expected property tax saving associated with the designation.
3. The Council may approve, approve with conditions, or deny the application. In the event the applicant does not follow the conditions, the application shall be deemed to be denied.
4. The City Administrator shall notify the County Board of Supervisors of the decision of the Council.

### **FACTORS TO CONSIDER IN DETERMINING WHETHER THE COUNCIL SHALL APPROVE A REQUEST:**

- The size of the parcel to be designated as natural conservation or wildlife area;
- The area's suitability for other use; that is, in the absence of the property tax abatement, would the ground likely develop or be used for other purpose;
- The amount of public access that will be available for the parcel;
- The impact of the proposal on surrounding property;
- The amount of tax revenue which will be lost by virtue of the approval of the request;
- The length of time the parcel is expected to remain as a nature conservation/wildlife area;
- The impact or potential impact the designation would have on benefiting environmental concerns such as storm water runoff, water quality, air quality, and the preservation or enhancement of native plant species; and
- The impact or potential impact the designation would have on benefiting wildlife habitat.

## COUNCIL LETTER

**MEETING DATE:** March 3, 2026 (SPH)  
March 17, 2026 (HPH)

**REQUESTED BY:** Chris Curran, City Attorney



---

### Item Title

Resolution setting the date for a public hearing for request for designation as Forest Covers for a portion of property located at 8822 Wells Ferry Road to qualify for tax exemption.

### Explanation

The Council has approved a policy on land set aside for conservation purposes. Gary and Elizabeth Fincher request property they own receive that designation. Pursuant to the policy, the council is asked to set a public hearing on the matter and send notice to adjacent property owners.

If approved, tax revenues from the property so designated will end.

### If the matter is not budgeted in the current year, explain why funding is requested and the anticipated source:

N/A

### List Attachments

- Resolution (SPH)
- Notice of Public Hearing
- Resolution
- Letter from Scott County
- Application
- Aerial Photo
- Policy

**RESOLUTION SETTING THE DATE FOR A PUBLIC HEARING FOR  
REQUEST FOR DESIGNATION AS FOREST COVERS FOR A PORTION OF  
PROPERTY LOCATED AT 8822 WELLS FERRY ROAD  
TO QUALIFY FOR TAX EXEMPTION**

**BE IT RESOLVED** by the City Council of the City of Bettendorf, Iowa, that a public hearing be set for 17<sup>th</sup> day of March, 2026, at 7:00 p.m. in the Council Chambers at City Hall, 1609 State Street, Bettendorf, to receive public comment on the request of the property owners at 8822 Wells Ferry Road to classify a portion of property they own within the city as forest covers qualify as tax exempt under Iowa Code Section 427.1(22).

**BE IT FURTHER RESOLVED** that the City Clerk is directed to mail notice of this request to all property owners within 200 feet of the subject property, as well as to the property owners, Gary and Elizabeth Fincher.

**PASSED, APPROVED AND ADOPTED** this 3<sup>rd</sup> day of March, 2026.

---

Robert S. Gallagher, Mayor

ATTEST:

---

Decker P. Ploehn, City Clerk

## **NOTICE OF PUBLIC HEARING**

### **To Whom It May Concern:**

Notice is hereby given that on the 17th day of March, 2026, at 7:00 p.m., the City Council of the City of Bettendorf, Iowa, will conduct a public hearing at City Hall, Council Chambers, 1609 State Street, regarding the request of the property owner(s) at 8822 Wells Ferry Road to classify a portion of property they own within the city as Forest Covers, and qualify as tax exempt.

The City Council has set said hearing at the time and place specified. Written suggestions or objections concerning this issue may be filed with the City Clerk at or before such hearing and will be heard by the City Council at the time and place specified.

Interested persons desiring to present their views upon the issue, either in writing or verbally, will be given the opportunity to be heard at the above mentioned time and place.

Dated at Bettendorf, Iowa, this 3rd day of March, 2026

Decker P. Ploehn, City Administrator

**APPROVING REQUEST FOR TAX EXEMPTION FOR  
8822 WELLS FERRY ROAD**

**WHEREAS**, the owners of property located at 8822 Wells Ferry Road have requested to have a portion of their property designated as tax exempt under Iowa Code Section 427.1(22) as Forest Covers; and

**WHEREAS**, pursuant to policy adopted by the City Council, the Council has held a public hearing on the request, and considered the comments of adjoining properties, if any.

**NOW, THEREFORE, BE IT RESOLVED** by the City Council of the City of Bettendorf, Iowa, said request is hereby approved.

**PASSED, APPROVED AND ADOPTED** the 17<sup>th</sup> day of March, 2026.

\_\_\_\_\_  
Robert S. Gallagher, Mayor

**ATTEST:**

\_\_\_\_\_  
Decker P. Ploehn, City Clerk

**OFFICE OF THE COUNTY ASSESSOR**

600 West 4<sup>th</sup> Street  
Davenport, Iowa 52801-1030  
Office: (563) 326-8635  
[www.scottcountyia.gov](http://www.scottcountyia.gov)  
[assessor@scottcountyia.gov](mailto:assessor@scottcountyia.gov)



---

TOM MCMANUS  
County Assessor

JOHN KELLY  
Deputy Assessor

February 18, 2026

**To:** Mahesh Sharma, Scott County Administrator

**From:** Tom R. McManus

**RE:** 2026 Slough Bill Applications

Enclosed is a list of the 2026 Slough Bill Tax Exemption applicants received from the Scott County Soil & Water Conservation District for the Board of Supervisors' approval. The City of Bettendorf will approve the applications within its jurisdiction. The total number of acres recommended for approval is 1,234.272, with a land value of \$1,697,900 in the rural area. The City of Davenport applications have been forwarded to the City of Davenport Assessor's Office.

If you need any additional information, please contact me or Amber Johnson at ext. 3218.

Thank you,  
Tom R. McManus  
Scott County Assessor

# Scott County Soil & Water Conservation District

8370 Hillandale Road, Davenport, Iowa 52806

Phone 563-391-1403 ext. 3 Fax 563-388-0682

Chad Dexter Lora Schmidt Joshua Witt Christine Bolte Tracey Kuehl



Soil & Water  
Conservation District

February 4<sup>th</sup>, 2026

Scott County Assessor  
600 W. 4<sup>th</sup> Street  
Davenport, IA 52801

Enclosed are this year's Natural Conservation or Wildlife Area Property Tax Exemption applications. The Scott County SWCD Commissioners have approved these applications as meeting the criteria for the stated exemption.

## Renewals

	Marianne Hamilton ✓	Forest Cover	18.10 acres
<del>DAVENPORT</del>	Shirley Perry	Open Prairie	5.0 acres
<del>DAVENPORT</del>	Dean Krueger	Open Prairie	22.51 acres
<del>DAVENPORT</del>	Genesis Systems Group LLC	Forest Cover	25.80 acres
	Haase Living Trust ✓	Open Prairie	7.0 acres
<del>DAVENPORT</del>	Burton Voss Trust	Forest Cover	5.602 acres
<del>DAVENPORT</del>	Brian Ritter	Forest Cover	57.59 acres
	Lawrence & Tara Youngers Rev Trust ✓	Forest Cover	3.80 acres
<del>DAVENPORT</del>	Plumb Supply Co LLC	Open Prairie	6.016 acres
	Jon Hilmann ✓	Forest Cover	2.4 acres
<del>DAVENPORT</del>	David Bierl	Forest Cover	15.0 acres
	Robert Kolwey ✓	Open Prairie	2.3 acres
	Richard Mohr ✓	Forest Cover	5.65 acres
	Charles Beason ✓	Forest Cover	22.98 acres
	Douglas Vickstrom Rev Trust ✓	Forest Cover	12.02 acres
	Greg Hawk ✓	Open Prairie	2.636 acres
	Tobin Living Trust ✓	Forest Cover	4.01 acres
<del>DETENDORF</del>	Judith A Tully Rev Trust ✓	Open Prairie	658.34 acres
	Ryan Living Trust ✓	Forest Cover	19.0 acres
	Michael Purcell ✓	Forest Cover	125.0 acres
	STL Properties LLC ✓	Forest Cover	10.7 acres
	Terry Rathje ✓	Forest Cover	5.0 acres
	Donald Kreiter ✓	Open Prairie	5.5 acres
	JC Davis Jr ✓	Forest Cover	3.1 acres
<del>DAVENPORT</del>	John Carrillo	Open Prairie	71.9 acres
		Open Prairie	4.2 acres
		Open Prairie	10.7 acres
		Rec Lake	1.3 acres
		Forest Cover	17.45 acres
		Open Prairie	6.6 acres

# Scott County Soil & Water Conservation District

8370 Hillandale Road, Davenport, Iowa 52806

Phone 563-391-1403 ext. 3 Fax 563-388-0682

Chad Dexter Lora Schmidt Joshua Witt Christine Bolte Tracey Kuehl

Anthony & Carrie Crossen ✓	Forest Cover	7.5 acres
Mark Wagemester (NEW FOR 2024)	River & Streambanks	3.94 acres
Alan & Nancy Henningsen ✓	Open Prairie	66.2 acres
	Forest Cover	59.3 acres
Andrew Claeys ✓	Forest Cover	17.31 acres
Andrew Strunk ✓	Forest Cover	2.0 acres
Kim Strunk ✓	Open Prairie	5.0 acres
LETTENDLE Gary & Elizabeth Fincher (NEW FOR 2024)	Forest Cover	10.7 acres
Brad Moeller ✓	Open Prairie	50.0 acres
	Forest Cover	16.48 acres
DAVENPORT CWC Series LLC Series D	Forest Cover	24.4 acres
Tony Singh (PRAIRIE DAKA)	Open Prairie	6.6 acres
LETTENDLE Chad A Miller Rev Trust	Forest Cover	2.0 acres
	River & Streambanks	2.3 acres
Ben Taylor (NEW FOR 2024)	Forest Cover	3.4 acres
DAVENPORT Senior Star Investments LLC	River & Streambanks	8.96 acres
	+ Open Prairie	
	+ Forest Cover	

## New

\*\*MBM Investments LLC (NEW FOR 2024) Open Prairie 3.25 acres

\*\*Parcel previously applied for under Jane Morrell

Please contact me if you have any questions.

Sincerely,

Rowan O.K. Kuechenmeister  
Conservation Assistant



IOWA DEPARTMENT OF  
AGRICULTURE &  
LAND STEWARDSHIP

Scott County Soil & Water Conservation District

8370 Hillandale Rd, Davenport IA 52806

563.391.1403 ext.3

[rowan.kuechenmeister@ia.nacdnet.net](mailto:rowan.kuechenmeister@ia.nacdnet.net)



Natural Conservation or Wildlife Areas
Property Tax Exemption

Iowa Code section 427.1(22)

This application must be filed or postmarked to your local soil and water conservation district on or before February 1 of each year. However, the exemption for the owner of property described under Iowa Code section 427.1(22)(g) shall continue from year to year without additional application as long as the property qualifies and is not used for economic gain. Iowa conservation district addresses can be found at the Conservation Districts of Iowa website: cdiowa.org.

Print property information

(4.52 AC)

(6.18 AC)

Parcel number: 943607006, 943607707, 943607007

Owner: Gary & Elizabeth Fincher

Property location address:

City: State: ZIP:

Property owner mailing address: 8822 Wells Ferry Rd

City: Bettendorf State: IA ZIP: 52722

County: Scott Number of acres: 10.70

Phone: (563) 349-9400 Email: garydonfincher@gmail.com

Print applicant information if other than owner

Name:

Applicant mailing address:

City: State: ZIP:

Phone: Email:

Relationship to owner:

Property type:

- Recreational lakes [ ] Rivers and streams [ ] Forest covers [x]
Open prairies [ ] River and stream banks [ ] Section 427.1(22)(g) property [ ]

An aerial photo of the property on which the property to be exempted is outlined:

Is included: [ ] Is on file with the assessor: [x]

If the property is a gully area susceptible to erosion, an erosion control map approved by the soil and conservation district commissioners: Is included [ ] Is on file with the assessor [ ]

I Gary and Elizabeth Fincher swear or affirm that the above property will not be used for economic gain of any kind during the assessment year. I declare under penalties of perjury or false certificate, that I have examined this application, and, to the best of my knowledge, it is true, correct, and complete.

Applicant signature: Gary Fincher Elizabeth E. Fincher Date: 12/6/2025

~~CSA~~

Scott

2-4-76





### Overview

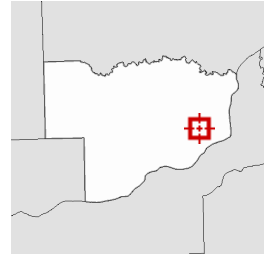

### Legend

- Political Township
- Corporate Limits
- County Boundary
- Railroad
- All Roads**
- Interstate
- US Highway
- State Highway
- County Route
- Major road
- Local roads
- Ramp
- Alleyway/Access Road
- Bike/Pedestrian Trail
- Driveway
- Rights of Way
- Major Rivers and Streams**
- River Centerline
- River Boundary
- Major Stream
- Minor Streams, Other**
- Minor Stream
- Small Lake/Pond
- Drainageways, etc
- Island
- Major Rivers and Lakes**
- Lake
- Major Stream
- River
- Minor Lakes and Ponds
- Parcels
- ◆ Parcel Point

## **POLICY ON APPROVAL OF TAX EXEMPTIONS FOR NATURAL CONSERVATION AND WILDLIFE AREAS**

**WHEREAS**, the Iowa Code Section 427.1 allows certain real estate to be maintained in tax exempt status when certain conditions are met; and

**WHEREAS**, for areas to be designated natural conversation and wildlife areas before such status can be approved within a city, city council permission must be granted; and

**WHEREAS**, the adoption of a policy on the consideration of such requests will help guide the Council in its decision making.

### **NOW THEREFORE UPON REQUEST BY THE COUNTY BOARD OF SUPERVISORS TO CONSIDER A TAX EXEMPTION REQUEST, THE COUNCIL SHALL:**

1. Mail notice to all property holders within 200 feet of the parcel under consideration of the request to designate the ground as natural conservation and wildlife area, and invite written or oral comment at the designated council meeting.
2. Request the applicant to come before the Council, to show the area being requested for tax exempt status, explain what actions the applicant has taken in order to establish the area as natural conservation or wildlife area, how long the application expects the ground to remain in that status, and the expected property tax saving associated with the designation.
3. The Council may approve, approve with conditions, or deny the application. In the event the applicant does not follow the conditions, the application shall be deemed to be denied.
4. The City Administrator shall notify the County Board of Supervisors of the decision of the Council.

### **FACTORS TO CONSIDER IN DETERMINING WHETHER THE COUNCIL SHALL APPROVE A REQUEST:**

- The size of the parcel to be designated as natural conservation or wildlife area;
- The area's suitability for other use; that is, in the absence of the property tax abatement, would the ground likely develop or be used for other purpose;
- The amount of public access that will be available for the parcel;
- The impact of the proposal on surrounding property;
- The amount of tax revenue which will be lost by virtue of the approval of the request;
- The length of time the parcel is expected to remain as a nature conservation/wildlife area;
- The impact or potential impact the designation would have on benefiting environmental concerns such as storm water runoff, water quality, air quality, and the preservation or enhancement of native plant species; and
- The impact or potential impact the designation would have on benefiting wildlife habitat.

## COUNCIL LETTER

**MEETING DATE:** March 3, 2026  
**REQUESTED BY:** Doug Scott, Police Chief



---

### **Item Title:**

Resolution approving the placement of a Parking for Persons with Disabilities sign at 510 Grant Street.

### **Explanation:**

Resident at 510 Grant Street is requesting a Parking for Persons with Disabilities space to assist with parking in front of this residence. This resident has a disabilities parking placard for their vehicle that has been verified by the police department.

### **If the matter is not budgeted in the current year, explain why funding is requested and the anticipated source:**

The cost for the sign and post.

### **List Attachments:**

Resolution

**RESOLUTION APPROVING THE PLACEMENT OF A PARKING FOR PERSONS WITH  
DISABILITIES SIGN AT 510 GRANT STREET**

BE IT RESOLVED by the City Council of the City of Bettendorf, Iowa, that a Parking for Persons with Disabilities space be created at the following location:

510 Grant Street

as provided in Section 6-1-138(A) of the City Code entitled, "Parking for Persons with Disabilities."

PASSED, APPROVED, and ADOPTED this 3<sup>rd</sup> day of March 2026.

---

Robert S. Gallagher, Mayor

ATTEST:

---

Decker P. Ploehn, City Clerk

## COUNCIL LETTER

**MEETING DATE:** March 3, 2026  
**REQUESTED BY:** Doug Scott, Police Chief



---

### **Item Title:**

Resolution approving the removal a Parking for Persons with Disabilities sign at 1524 Mississippi Boulevard.

### **Explanation:**

A dedicated Parking for Persons with Disabilities (ADA) space was approved by city council on December 12, 2001, via Resolution 308-01. The property owner no longer needs the ADA parking space and requests its removal. Staff will proceed with removal of the sign upon approval of this resolution.

### **If the matter is not budgeted in the current year, explain why funding is requested and the anticipated source:**

There is no cost associated with this request.

### **List Attachments:**

Resolution

**RESOLUTION APPROVING THE REMOVAL OF A PARKING FOR PERSONS WITH  
DISABILITIES SIGN AT 1524 MISSISSIPPI BOULEVARD**

WHEREAS, City Code section 6-1-138(A) requires any dedicated Parking for Persons with Disabilities (ADA) space be approved by resolution; and

WHEREAS, Resolution 308-01 approved such a space at 1524 Mississippi Boulevard; and

WHEREAS, the property owner no longer needs the ADA parking space.

NOW, THEREFORE, BE IT RESOLVED by the City Council of the City of Bettendorf, Iowa, that Resolution 308-01 be revoked and staff is directed to remove the existing ADA parking sign.

PASSED, APPROVED, and ADOPTED this 3<sup>rd</sup> day of March 2026.

---

Robert S. Gallagher, Mayor

ATTEST:

---

Decker P. Ploehn, City Clerk

## COUNCIL LETTER

**MEETING DATE:** March 3, 2026

**REQUESTED BY:** Michelle Spencer, Sr. Admin. Assistant



---

### Item Title

Resolution approving Tobacco Retailer Permits.

### Explanation

Hy-Vee Food Store and Hy-Vee Fast & Fresh have properly applied for their FY26/27 Tobacco Retailer Permit through the State of Iowa as required by Iowa Code Chapter 453A. Upon the city's approval, the state will issue the respective permits.

### If the matter is not budgeted in the current year, explain why funding is requested and the anticipated source:

N/A

### List Attachments

- Resolution

**RESOLUTION APPROVING TOBACCO RETAILER PERMITS**

**WHEREAS**, the City Council of the City of Bettendorf, Iowa have received application(s) for FY26/27 tobacco retailer permit from Hy-Vee Food Store and Hy-Vee Fast & Fresh.

**BE IT RESOLVED** by the City Council of the City of Bettendorf, Iowa, that pursuant to Iowa Code Chapter 453A the aforementioned request(s) are hereby approved.

**BE IT FURTHER RESOLVED** that the City Clerk is directed to certify to the Iowa Department of Revenue, Tobacco Licensing Division, the City Council's approval of said applications.

**PASSED, APPROVED AND ADOPTED** this 3<sup>rd</sup> day of March, 2026.

---

Robert S. Gallagher, Mayor

ATTEST:

---

Decker P. Ploehn, City Clerk

## COUNCIL LETTER

**MEETING DATE:** March 3, 2026

**REQUESTED BY:** Michelle Spencer, Sr. Admin. Assistant



---

### Item Title

Resolution approving alcohol license renewals and requests.

### Explanation

The Licensing of businesses contribute to the mission of a growing, competitive business environment. The applicant(s) for Willy's Wine & Spirits, Indian Garden Bar & Grill, Plus Saporis Mediterranean Latin Cuisine, Scrub Pub, Azteca III, and Express Lane Gas & Food Mart have submitted the necessary documentation to issue the respective license and/or permits as required by the State of Iowa.

A criminal history background check has been requested and/or conducted.

The Bettendorf Fire Department has determined that the applicants are in compliance with federal, state, and local requirements.

### If the matter is not budgeted in the current year, explain why funding is requested and the anticipated source:

N/A

### List Attachments

- Resolution

**RESOLUTION APPROVING ALCOHOL LICENSE RENEWALS  
AND REQUESTS**

**WHEREAS**, the City Council of the City of Bettendorf, Iowa has received application for the following alcohol license renewals and/or requests:

License renewals for Willy's Wine & Spirits, Indian Garden Bar & Grill, Plus Saporis Mediterranean Latin Cuisine, and Scrub Pub; a new license for Azteca III, and ownership updates for Express Lane Gas & Food Mart locations (State St and Devils Glen Rd)

**BE IT RESOLVED** by the City Council of the City of Bettendorf, Iowa, that pursuant to Iowa Code Chapter 123 the applications be approved; and

**BE IT FURTHER RESOLVED** that the City Clerk is herewith directed to certify to the Iowa Department of Commerce, Alcoholic Beverages Division, the City Council's approval of said applications.

**PASSED, APPROVED AND ADOPTED** this 3<sup>rd</sup> day of March, 2026

---

Robert S. Gallagher, Mayor

ATTEST:

---

Decker P. Ploehn, City Clerk

Bettendorf City Council AP Disbursements - 03.03.26

Vendor Name	Check Date	Check #	Invoice Date	Invoice #	Memo	Amount	Fund	Dept	Account #	Project
WAGeworks	1/21/2026	2600417	1/20/2026	INV8634773	flex claims	3,763.49	General Fund	Balance Sheet	1001-0000-20502	
WAGeworks	1/27/2026	2600420	1/26/2026	INV8666434	flex claims	3,155.31	General Fund	Balance Sheet	1001-0000-20502	
WAGeworks	2/3/2026	2600425	2/2/2026	INV8685056	flex claims	2,907.84	General Fund	Balance Sheet	1001-0000-20502	
WAGeworks	2/10/2026	2600430	2/9/2026	INV8710226	flex claims	1,731.04	General Fund	Balance Sheet	1001-0000-20502	
JAMES VERDICK	2/18/2026	133079	2/18/2026	2182026	REFUND FOR 2026 RENTAL REGISTRATION NO LONGER GOING TO BE A RENTAL AT THIS TIME ADDRESS: 1331 14TH ST REG 10705 JAMES VERDICK	50.00	General Fund	Balance Sheet	1001-0000-20504	
JAMES VERDICK	2/18/2026	133079	2/18/2026	2182026	REFUND FOR 2026 RENTAL REGISTRATION NO LONGER GOING TO BE A RENTAL AT THIS TIME ADDRESS: 1327 14TH ST REG 10704 JAMES VERDICK	50.00	General Fund	Balance Sheet	1001-0000-20504	
						<b>11,657.68</b>		<b>Balance Sheet Total</b>		
VISIT QUAD CITIES	2/18/2026	133088	10/1/2025	QCCVB09302025	25% HOTEL/MOTEL TAX 1ST QUARTER FY26	122,844.15	General Fund	Mayor & Council	1001-0101-55013	
DPHILMS/DINGELDEIN PHILMS, INC	3/4/2026	133137	12/31/2025	30780	State of the City Livestream	3,140.00	General Fund	Mayor & Council	1001-0101-56007	State of the City
LYLE SUMEK ASSOCIATES, INC.	2/25/2026	133104	2/6/2026	26-0101	Strategic Planning Final Reports	2,750.00	General Fund	Mayor & Council	1001-0101-55072	
WATERFRONT DELI & RESTAURANT	2/25/2026	133114	2/9/2026	168451	Budget Work Session 2/9/26	245.60	General Fund	Mayor & Council	1001-0101-53004	
QUAD CITIES CHAMBER OF COMMERCE	2/25/2026	133110	2/12/2026	102262	Registration for Council Member CFlaherty - IA Capitol Trip, Feb 10-11, 2026	150.00	General Fund	Mayor & Council	1001-0101-53004	
EDMUND C GRABER	3/4/2026	133139	2/23/2026	22326	Consulting Services February 1-28, 2026	1,832.00	General Fund	Mayor & Council	1001-0101-55013	
RIHLAN MITAL	2/25/2026	133111	2/25/2026	22526	Home Base Iowa Reimbursement.	900.00	General Fund	Mayor & Council	1001-0101-55082	
						<b>131,861.75</b>		<b>Mayor &amp; Council Total</b>		
MERCHANT SERVICES	2/23/2026	2600367	11/30/2025	1125	Bankcard fees 1 % sw1 ,sw2,sw3	68.62	General Fund	Finance	1001-0201-55032	
UMB BANK	1/27/2026	2600421	1/9/2026	1035272	AGENT FEES	600.00	General Fund	Finance	1001-0202-55034	
ROCHESTER ARMORED CAR CO., INC.	3/4/2026	133194	1/31/2026	204238A	Armored Car Transportation	433.20	General Fund	Finance	1001-0202-55081	
VESTIS	3/4/2026	133212	2/9/2026	6150677258	FIRST AID	29.98	General Fund	Finance	1001-0202-56007	
CINTAS	3/4/2026	133126	2/13/2026	5318440810	New First aid	423.59	General Fund	Finance	1001-0202-56007	
VESTIS	2/25/2026	133113	2/16/2026	6150680554	first aid	29.98	General Fund	Finance	1001-0202-56007	
						<b>1,585.37</b>		<b>Finance Total</b>		
PRESTIGE AUTO BODY LLC	3/4/2026	133184	1/31/2026	20586	2025 Nissan Pathfinder	270.31	General Fund	Police	1001-0311-54004	
RACOM	3/4/2026	133187	2/25/2026	INV42169	Tear out of equipment on city vehicle 21620	780.00	General Fund	Police	1001-0311-54004	
SCOTT COUNTY SHERIFF'S OFFICE	3/4/2026	133198	1/31/2026	2026-00000081	January 2026 Booking Fees	1,675.00	General Fund	Police	1001-0315-55081	
TRITECH SOFTWARE SYSTEMS	3/4/2026	133207	1/31/2026	437981	Annual Maintenance Fee	1,773.37	General Fund	Police	1001-0315-55081	
H AND H CAR CARE AND TOWING LLC	2/18/2026	133077	2/7/2026	51891	Vehicle towed to BPD	205.00	General Fund	Police	1001-0315-55081	
PUSH PEDAL, PULL INC.	3/4/2026	133185	2/14/2026	417968	Treadmill Repairs	180.00	General Fund	Police	1001-0315-54006	
STREICHER'S INC	3/4/2026	133200	2/4/2026	11808505	Vests - ERU	1,949.00	General Fund	Police	1001-0318-56004	
						<b>6,832.68</b>		<b>Police Total</b>		
LOGO PRO, LLC	2/25/2026	133103	2/17/2026	28937	Job Shirt/Deckert	23.50	General Fund	Fire	1001-0411-52009	
LOGO PRO, LLC	2/25/2026	133103	2/17/2026	28890	Duty Sweatshirts	701.50	General Fund	Fire	1001-0411-52009	
JOHNSON CONTROLS SECURITY SOLUTIONS	3/4/2026	133155	2/7/2026	42151173	Annual Alarm Monitoring Contract	880.15	General Fund	Fire	1001-0415-54001	
THYMET PEST CONTROL	2/25/2026	133112	2/11/2026	160813	Monthly Service/ST2	58.00	General Fund	Fire	1001-0415-55081	
PUSH PEDAL, PULL INC.	3/4/2026	133185	2/14/2026	417968	Treadmill Repairs	179.99	General Fund	Fire	1001-0415-54006	
PS3 ENTERPRISES, INC	2/25/2026	133109	2/17/2026	190287	Unit Rental Feb. 2026/TC	110.00	General Fund	Fire	1001-0415-55081	
						<b>1,953.14</b>		<b>Fire Total</b>		
MECHANICAL SALES PARTS IOWA	3/4/2026	133172	1/1/2026	16408	RTU 1 Repairs	2,265.00	General Fund	Public Works	1001-0525-54001	City Hall Maint FY25/26
KONE INC.	3/4/2026	133160	2/1/2026	871927787	Quarterly Maintenance	245.17	General Fund	Public Works	1001-0525-54001	Maint Ctr Maint FY25/26
KONE INC.	3/4/2026	133160	2/1/2026	871927787	Quarterly Maintenance	245.17	General Fund	Public Works	1001-0525-54001	City Hall Maint FY25/26
KONE INC.	3/4/2026	133160	2/1/2026	871927787	Quarterly Maintenance	490.38	General Fund	Public Works	1001-0525-54001	Library Maint FY25/26
JOHNSON CONTROLS SECURITY SOLUTIONS	3/4/2026	133155	2/7/2026	42151174	Annual Alarm Monitoring Contract	835.47	General Fund	Public Works	1001-0525-54001	Comm Ctr Maint FY25/26
JOHNSON CONTROLS SECURITY SOLUTIONS	3/4/2026	133156	2/7/2026	42151172	Annual Alarm Monitoring Contract	2,129.76	General Fund	Public Works	1001-0525-54001	Maint Ctr Maint FY25/26
DOORS INC.	3/4/2026	133136	2/9/2026	371133	Key Copies	18.00	General Fund	Public Works	1001-0525-54001	Maint Ctr Maint FY25/26
THYMET PEST CONTROL	3/4/2026	133205	2/17/2026	160953	Pest control	58.00	General Fund	Public Works	1001-0525-55081	Maint Ctr Maint FY25/26
GFL ENVIRONMENTAL SERVICES USA, INC	3/4/2026	133145	1/28/2026	LQ03249155	Used Oil	243.65	General Fund	Public Works	1001-0572-54004	
S J SMITH CO. INC.	3/4/2026	133195	1/31/2026	843117	Rental Supplies	10.85	General Fund	Public Works	1001-0572-55081	
S J SMITH CO. INC.	3/4/2026	133195	1/31/2026	843118	Rental Supplies	21.70	General Fund	Public Works	1001-0572-55081	
S J SMITH CO. INC.	3/4/2026	133195	1/31/2026	843116	Rental Supplies	65.10	General Fund	Public Works	1001-0572-55081	
CITY OF DAVENPORT	3/4/2026	133128	2/3/2026	1339659	Compost Debris	330.00	General Fund	Public Works	1001-0572-56025	
VAN WALL EQUIPMENT, INC.	3/4/2026	133211	2/10/2026	6804305	John Deere Mower Repairs	1,276.56	General Fund	Public Works	1001-0572-54004	
WASTE COMMISSION OF SCOTT CO.	3/4/2026	133213	2/18/2026	01-01387157	Compost Materials	65.13	General Fund	Public Works	1001-0572-56025	
						<b>8,299.94</b>		<b>Public Works Total</b>		
MERCHANT SERVICES	2/23/2026	2600367	11/30/2025	1125	Bankcard fees Library	120.03	General Fund	Library	1001-0601-55032	
						<b>120.03</b>		<b>Library Total</b>		
OFFICE EXPRESS OFFICE PRODUCTS	3/4/2026	133181	2/4/2026	156087	Printer Paper	419.90	General Fund	Parks & Recreation	1001-0703-56006	

Bettendorf City Council AP Disbursements - 03.03.26

Vendor Name	Check Date	Check #	Invoice Date	Invoice #	Memo	Amount	Fund	Dept	Account #	Project
NATALIE QUINN	3/4/2026	133178	2/9/2026	260209	12520 Kid's Yoga Class Instruction	180.00	General Fund	Parks & Recreation	1001-0703-55081	Kid Yoga & Mindfulness
JENNIFER HARL	3/4/2026	133151	2/9/2026	260209	12520 Kid's Yoga Class Instruction	180.00	General Fund	Parks & Recreation	1001-0703-55081	Kid Yoga & Mindfulness
LITTLE SWEETS CAKE DESIGN	3/4/2026	133167	2/9/2026	260209	12569 Cake Decorating Workshop Instruction	880.00	General Fund	Parks & Recreation	1001-0703-55081	Addie Corby Classes
LAURA ANDERSON	3/4/2026	133162	2/17/2026	260217	12867 Balloon Twisting Workshop Instruction	180.00	General Fund	Parks & Recreation	1001-0703-55081	Balloon Twisting Classes
LINDA JONES	3/4/2026	133165	2/17/2026	260217	12373 Jr Chefs Cooking Class Instruction	400.00	General Fund	Parks & Recreation	1001-0703-55081	Linda Jones Classes
OFFICE EXPRESS OFFICE PRODUCTS	3/4/2026	133181	2/4/2026	156087	Printer Paper	419.90	General Fund	Parks & Recreation	1001-0705-56006	
VESTIS	3/4/2026	133212	2/9/2026	6150677264	First Aid Service	29.98	General Fund	Parks & Recreation	1001-0705-56010	
VESTIS	3/4/2026	133212	2/16/2026	6150680559	First Aid Services	29.98	General Fund	Parks & Recreation	1001-0705-56010	
KOHL WHOLESale	3/4/2026	133159	1/28/2026	1518779	Frozen - Resale	152.89	General Fund	Parks & Recreation	1001-0730-56026	
JOHANNES BUS SERVICE, INC.	3/4/2026	133154	1/31/2026	47372	12304, 12305 Skiing/Snowboarding Bus	2,450.00	General Fund	Parks & Recreation	1001-0730-55081	Skiing & Snowboarding Lessons
KOHL WHOLESale	3/4/2026	133159	2/2/2026	1523189	Frozen - Resale	59.65	General Fund	Parks & Recreation	1001-0730-56026	
VESTIS	3/4/2026	133212	2/5/2026	6150676008	Laundry Services	59.10	General Fund	Parks & Recreation	1001-0730-55081	
VESTIS	3/4/2026	133212	2/5/2026	6150676008	First Aid Service	14.99	General Fund	Parks & Recreation	1001-0730-56010	
KOHL WHOLESale	3/4/2026	133159	2/6/2026	1527827	Concession Supplies	20.33	General Fund	Parks & Recreation	1001-0730-56007	
KOHL WHOLESale	3/4/2026	133159	2/6/2026	1527827	Candy/Frozen - Resale	288.83	General Fund	Parks & Recreation	1001-0730-56026	
COCA-COLA ATLANTIC BOTTLING CO	3/4/2026	133130	2/11/2026	5593521	5 Cases Drinks - Resale	83.52	General Fund	Parks & Recreation	1001-0730-56026	
AMERIGAS PROPANE LP	3/4/2026	133120	2/11/2026	3186830993	Propane Refills - Zamboni	73.60	General Fund	Parks & Recreation	1001-0730-54026	
VESTIS	3/4/2026	133212	2/12/2026	6150679299	Laundry Services	59.10	General Fund	Parks & Recreation	1001-0730-55081	
VESTIS	3/4/2026	133212	2/12/2026	6150679299	First Aid Service	14.99	General Fund	Parks & Recreation	1001-0730-56010	
KOHL WHOLESale	3/4/2026	133159	2/12/2026	1533487	Chips/Frozen - Resale	170.67	General Fund	Parks & Recreation	1001-0730-56026	
PATRIK LEVESQUE	3/4/2026	133182	2/17/2026	260217	12885, 12886, 12887 Ice Skating Lesson Instruction	2,720.00	General Fund	Parks & Recreation	1001-0730-55081	
BI-STATE BARRICADE AND FLAGGING	2/18/2026	133076	12/31/2025	9471	Barricades for 4th of July 2025	2,900.00	General Fund	Parks & Recreation	1001-0740-55015	4th of July
AAA RENTS INC.	3/4/2026	133116	2/1/2026	100421	Tent Rental for Winterfest	1,674.00	General Fund	Parks & Recreation	1001-0740-55015	Winter Carnival
ROBERT STORM	3/4/2026	133193	2/2/2026	2080743	Winterfest Ice Carving	600.00	General Fund	Parks & Recreation	1001-0740-55081	Winter Carnival
NATHAN BERTHOUD	2/25/2026	133107	2/3/2026	2126	DJ Services at Winterfest 2026	700.00	General Fund	Parks & Recreation	1001-0740-55081	Winter Carnival
						<b>14,761.43</b>		<b>Parks &amp; Recreation Total</b>		
MERCHANT SERVICES	2/23/2026	2600367	11/30/2025	1125	Bankcard fees inspections	1,576.00	General Fund	Community Development	1001-3006-55032	
						<b>1,576.00</b>		<b>Community Development Total</b>		
DOWNTOWN BETTENDORF ORGANIZATION	2/25/2026	133101	2/12/2026	26-194	Holiday Lighting and Support, matched by the DBO	5,000.00	General Fund	Economic Development	1001-3501-55033	
LOGO PRO, LLC	3/4/2026	133168	2/17/2026	28860	City of Bettendorf USB Drives (100)	330.00	General Fund	Economic Development	1001-3501-56006	
						<b>5,330.00</b>		<b>Economic Development Total</b>		
LOGO PRO, LLC	2/25/2026	133103	2/4/2026	27887	City Logo key chains	665.33	General Fund	City Administration	1001-4101-56033	
LOGO PRO, LLC	2/25/2026	133103	2/6/2026	28762	Donor appreciation expense - referendum supporters	523.67	General Fund	City Administration	1001-4101-56033	
BI-STATE REGIONAL COMMISSION	2/25/2026	133099	2/9/2026	11642	Iowa Intergovernmental Mtg 2/4/26 - City Administrator DPloehn	18.60	General Fund	City Administration	1001-4101-53004	
COUNTRY CLUB COFFEE	2/25/2026	133100	2/11/2026	43856	Coffee Supplies for City Hall & Police Dept	257.08	General Fund	City Administration	1001-4101-56006	
BI-STATE REGIONAL COMMISSION	3/4/2026	133124	2/11/2026	11661	MAC Mtg 2/6/26 - City Administrator DPloehn	23.86	General Fund	City Administration	1001-4101-53004	
COUNTRY CLUB COFFEE	3/4/2026	133131	2/24/2026	44250	Coffee Supplies for City Hall & PD	112.10	General Fund	City Administration	1001-4101-56006	
MERCHANT SERVICES	2/23/2026	2600367	11/30/2025	1125	Bankcard fees Business Lie	59.98	General Fund	City Administration	1001-4102-55032	
QUAD CITY TIMES	2/18/2026	133083	1/30/2026	213504	Publish city council meeting minutes & bills 1/20/26 meeting	1,279.69	General Fund	City Administration	1001-4102-55014	
FEDEX	3/4/2026	133142	2/18/2026	9-183-34387	Overnight documents to Ahlers related to Bond Sale	54.29	General Fund	City Administration	1001-4102-56007	
						<b>2,994.60</b>		<b>City Administration Total</b>		
RYAN KILLEAN	2/18/2026	133086	2/13/2026	2132026	Tuition Reimbursement - Applications of Fire Research 4710, Winter Session	459.00	General Fund	Human Resources	1001-4201-53005	
GENESIS OCCUPATIONAL HEALTH	3/4/2026	133144	2/17/2026	234661	Employee testing, INV 234661	187.00	General Fund	Human Resources	1001-4201-55013	
RANDY RICHARDS	3/4/2026	133188	2/24/2026	2242026	Leadership and Next Level Leadership class on 2/24/2026	1,400.00	General Fund	Human Resources	1001-4201-53003	
						<b>2,046.00</b>		<b>Human Resources Total</b>		
						<b>189,018.62</b>	<b>General Fund Total</b>			
VESTIS	3/4/2026	133212	2/11/2026	6150679628	First Aid Supplies	29.98	Road Use Fund	Public Works	2060-0501-56006	
CINTAS	3/4/2026	133127	2/13/2026	5318440803	First Aid Supplies	423.59	Road Use Fund	Public Works	2060-0501-56006	
CULLIGAN OF DAVENPORT	3/4/2026	133132	2/13/2026	561184	Water	44.20	Road Use Fund	Public Works	2060-0501-56006	
VESTIS	3/4/2026	133212	2/18/2026	6150681943	First Aid Supplies	29.98	Road Use Fund	Public Works	2060-0501-56006	
RIVERSTONE GROUP INC.	3/4/2026	133192	2/17/2026	7888	Plex Stone	400.00	Road Use Fund	Public Works	2060-0502-55081	
RIVERSTONE GROUP INC.	3/4/2026	133192	2/10/2026	1459001	UPM Cold Mix	274.35	Road Use Fund	Public Works	2060-0511-56007	
RIVERSTONE GROUP INC.	3/4/2026	133192	2/17/2026	1460435	UPM Cold Mix	491.35	Road Use Fund	Public Works	2060-0511-56007	
MID AMERICAN ENERGY	2/18/2026	133082	2/2/2026	576645661	2218 SPRUCE HILLS DR BETTENDORF IA 52722	10.00	Road Use Fund	Public Works	2060-0530-54008	
MID AMERICAN ENERGY	2/18/2026	133082	2/2/2026	576641251	2210 SPRUCE HILLS DR BETTENDORF IA 52722	10.00	Road Use Fund	Public Works	2060-0530-54008	
MID AMERICAN ENERGY	2/18/2026	133082	2/2/2026	576644990	2206 SPRUCE HILLS DR BETTENDORF IA 52722	10.00	Road Use Fund	Public Works	2060-0530-54008	
MID AMERICAN ENERGY	2/18/2026	133082	2/2/2026	576649018	2202 SPRUCE HILLS DR BETTENDORF IA 52722	10.00	Road Use Fund	Public Works	2060-0530-54008	
MID AMERICAN ENERGY	2/18/2026	133082	2/2/2026	576645123	2226 SPRUCE HILLS DR	16.38	Road Use Fund	Public Works	2060-0530-54008	
MID AMERICAN ENERGY	2/18/2026	133082	2/2/2026	576652556	2214 SPRUCE HILLS DR BETTENDORF IA 52722	24.72	Road Use Fund	Public Works	2060-0530-54008	

Bettendorf City Council AP Disbursements - 03.03.26

Vendor Name	Check Date	Check #	Invoice Date	Invoice #	Memo	Amount	Fund	Dept	Account #	Project
MID AMERICAN ENERGY	2/18/2026	133082	2/2/2026	576655827	2201 MIDDLE RD BETTENDORF IA 52722	52.54	Road Use Fund	Public Works	2060-0530-54008	
MID AMERICAN ENERGY	2/18/2026	133082	2/5/2026	576815577	2222 SPRUCE HILLS DR BETTENDORF IA 52722	17.39	Road Use Fund	Public Works	2060-0530-54008	
MID AMERICAN ENERGY	3/4/2026	133174	2/13/2026	577189141	45081-51006 (4798 Forest Grove Dr)	71.91	Road Use Fund	Public Works	2060-0530-54008	
MID AMERICAN ENERGY	3/4/2026	133174	2/13/2026	577194015	53581-66026 (6850 Middle Rd)	247.91	Road Use Fund	Public Works	2060-0530-54008	
						<b>2,164.30</b>	<b>Road Use Fund Total</b>			
TRI-CITY ELECTRIC CO	2/18/2026	133087	12/20/2025	129592	Halo License Renewal	123.00	Capital Projects	Capital Projects	4000-5050-56007	Video Enhancement - Pd
GRAYBAR (DATA)	3/4/2026	133146	2/4/2026	9351925806	Fiber Case	516.32	Capital Projects	Capital Projects	4000-5050-56007	Update Traffic Signals
TERRACON CONSULTANTS, INC.	3/4/2026	133202	2/9/2026	TQ27184	Soil boring for new Police Station	5,250.00	Capital Projects	Capital Projects	4000-5050-55072	Police Station Construction
REPUBLIC COMPANIES	3/4/2026	133190	2/10/2026	6308400-00	PVC Conduit	47.28	Capital Projects	Capital Projects	4000-5050-56007	Update Traffic Signals
TERRY-DURIN COMPANY	3/4/2026	133203	2/10/2026	206882-00	Downtown Decorative Light Pole Bulb Replacement	2,601.00	Capital Projects	Capital Projects	4000-5050-57074	Dwnntn Dec Light Pole Rep
LANGE SIGN GROUP, INC.	3/4/2026	133161	2/10/2026	34744	Illuminated logo sample	954.00	Capital Projects	Capital Projects	4000-5050-56007	Middle Ped Bridge
REPUBLIC COMPANIES	3/4/2026	133190	2/11/2026	6308526-00	Disconnect Materials	201.15	Capital Projects	Capital Projects	4000-5050-56007	Update Traffic Signals
GRAYBAR (DATA)	3/4/2026	133146	2/11/2026	9352008861	Fiber Housing	516.32	Capital Projects	Capital Projects	4000-5050-56007	Update Traffic Signals
GENERAL TRAFFIC CONTROLS INC	3/4/2026	133143	2/12/2026	27216	Lighted Street Signs	18,564.00	Capital Projects	Capital Projects	4000-5050-57074	Lighted Street Signs
GENERAL TRAFFIC CONTROLS INC	3/4/2026	133143	2/12/2026	27216	CO #1 - Freight	495.00	Capital Projects	Capital Projects	4000-5050-57074	Lighted Street Signs
REPUBLIC COMPANIES	3/4/2026	133190	2/12/2026	6308631-00	Conduit Connector	12.92	Capital Projects	Capital Projects	4000-5050-56007	Update Traffic Signals
TERRY-DURIN COMPANY	3/4/2026	133203	2/13/2026	206882-01	Downtown Decorative Light Pole Bulb Replacement	8,652.00	Capital Projects	Capital Projects	4000-5050-57074	Dwnntn Dec Light Pole Rep
LIGHTMART	3/4/2026	133164	2/17/2026	INV365969	Light Poles	9,184.00	Capital Projects	Capital Projects	4000-5050-57074	Middle & I-80 Cost Share
DAVENPORT ELECTRIC CONTRACT	3/4/2026	133133	2/19/2026	59634	Generator Install at Frozen Landing	4,790.50	Capital Projects	Capital Projects	4000-5050-55081	Frozen Landing Replacmnt
BI-STATE BARRICADE AND FLAGGING	3/4/2026	133123	2/23/2026	9116	Traffic Control for I74 & Middle. Invoice date 3/14/2025.	350.00	Capital Projects	Capital Projects	4000-5050-55081	Update Traffic Signals
						<b>52,257.49</b>	<b>Capital Projects Total</b>			
ENTERPRISE FM TRUST	2/23/2026	2600368	12/3/2025	FBN5515163	Lease Principal Dec 2025 26G59H	942.51	Vehicle Replacement Fund	Finance	4010-0209-58007	
ENTERPRISE FM TRUST	2/23/2026	2600368	12/3/2025	FBN5515163	Lease Interest 26G59H	5.88	Vehicle Replacement Fund	Finance	4010-0209-58005	
ENTERPRISE FM TRUST	2/23/2026	2600368	12/3/2025	FBN5515163	Lease Principal Dec 2025 26G5BG	926.59	Vehicle Replacement Fund	Finance	4010-0209-58007	
ENTERPRISE FM TRUST	2/23/2026	2600368	12/3/2025	FBN5515163	Lease Interest 26G5BG	5.78	Vehicle Replacement Fund	Finance	4010-0209-58005	
ENTERPRISE FM TRUST	2/23/2026	2600368	12/3/2025	FBN5515163	Lease Principal Dec 2025 26G5NF	1,330.48	Vehicle Replacement Fund	Finance	4010-0209-58007	
ENTERPRISE FM TRUST	2/23/2026	2600368	12/3/2025	FBN5515163	Lease Interest 26G5NF	61.89	Vehicle Replacement Fund	Finance	4010-0209-58005	
ENTERPRISE FM TRUST	2/23/2026	2600368	12/3/2025	FBN5515163	Lease Principal Dec 2025 26G5QP	1,513.93	Vehicle Replacement Fund	Finance	4010-0209-58007	
ENTERPRISE FM TRUST	2/23/2026	2600368	12/3/2025	FBN5515163	Lease Interest 26G5QP	112.13	Vehicle Replacement Fund	Finance	4010-0209-58005	
ENTERPRISE FM TRUST	2/23/2026	2600368	12/3/2025	FBN5515163	Lease Principal Dec 2025 26R3JM	1,478.37	Vehicle Replacement Fund	Finance	4010-0209-58007	
ENTERPRISE FM TRUST	2/23/2026	2600368	12/3/2025	FBN5515163	Lease Interest 26R3JM	104.59	Vehicle Replacement Fund	Finance	4010-0209-58005	
ENTERPRISE FM TRUST	2/23/2026	2600368	12/3/2025	FBN5515163	Lease Principal Dec 2025 26R3K7	1,581.00	Vehicle Replacement Fund	Finance	4010-0209-58007	
ENTERPRISE FM TRUST	2/23/2026	2600368	12/3/2025	FBN5515163	Lease Interest 26R3K7	111.85	Vehicle Replacement Fund	Finance	4010-0209-58005	
ENTERPRISE FM TRUST	2/23/2026	2600368	12/3/2025	FBN5515163	Lease Principal Dec 2025 22K3R	1,579.99	Vehicle Replacement Fund	Finance	4010-0209-58007	
ENTERPRISE FM TRUST	2/23/2026	2600368	12/3/2025	FBN5515163	Lease Interest 22K3R	111.78	Vehicle Replacement Fund	Finance	4010-0209-58005	
ENTERPRISE FM TRUST	2/23/2026	2600368	12/3/2025	FBN5515163	Lease Principal Dec 2025 26ZK4S	1,588.29	Vehicle Replacement Fund	Finance	4010-0209-58007	
ENTERPRISE FM TRUST	2/23/2026	2600368	12/3/2025	FBN5515163	Lease Interest 26ZK4S	112.36	Vehicle Replacement Fund	Finance	4010-0209-58005	
ENTERPRISE FM TRUST	2/23/2026	2600368	12/3/2025	FBN5515163	Lease Principal Dec 2025 26G89T	1,515.51	Vehicle Replacement Fund	Finance	4010-0209-58007	
ENTERPRISE FM TRUST	2/23/2026	2600368	12/3/2025	FBN5515163	Lease Interest 26G89T	138.32	Vehicle Replacement Fund	Finance	4010-0209-58005	
ENTERPRISE FM TRUST	2/23/2026	2600368	12/3/2025	FBN5515163	Lease Principal Dec 2025 275WN3	1,144.19	Vehicle Replacement Fund	Finance	4010-0209-58007	
ENTERPRISE FM TRUST	2/23/2026	2600368	12/3/2025	FBN5515163	Lease Interest 275WN3	112.25	Vehicle Replacement Fund	Finance	4010-0209-58005	
ENTERPRISE FM TRUST	2/23/2026	2600368	12/3/2025	FBN5515163	Lease Principal Dec 2025 26G5PJ	1,375.84	Vehicle Replacement Fund	Finance	4010-0209-58007	
ENTERPRISE FM TRUST	2/23/2026	2600368	12/3/2025	FBN5515163	Lease Interest 26G5PJ	126.36	Vehicle Replacement Fund	Finance	4010-0209-58005	
ENTERPRISE FM TRUST	2/23/2026	2600368	12/3/2025	FBN5515163	Lease Principal Dec 2025 26GXV7	1,473.85	Vehicle Replacement Fund	Finance	4010-0209-58007	
ENTERPRISE FM TRUST	2/23/2026	2600368	12/3/2025	FBN5515163	Lease Interest 26GXV7	135.36	Vehicle Replacement Fund	Finance	4010-0209-58005	
ENTERPRISE FM TRUST	2/23/2026	2600368	12/3/2025	FBN5515163	Lease Principal Dec 2025 273JSZ	1,050.15	Vehicle Replacement Fund	Finance	4010-0209-58007	
ENTERPRISE FM TRUST	2/23/2026	2600368	12/3/2025	FBN5515163	Lease Interest 273JSZ	107.92	Vehicle Replacement Fund	Finance	4010-0209-58005	
ENTERPRISE FM TRUST	2/23/2026	2600368	12/3/2025	FBN5515163	Lease Principal Dec 2025 273JWI	1,056.62	Vehicle Replacement Fund	Finance	4010-0209-58007	
ENTERPRISE FM TRUST	2/23/2026	2600368	12/3/2025	FBN5515163	Lease Interest 273JWI	108.59	Vehicle Replacement Fund	Finance	4010-0209-58005	
ENTERPRISE FM TRUST	2/23/2026	2600368	12/3/2025	FBN5515163	Lease Principal Dec 2025 26WVN2	1,437.55	Vehicle Replacement Fund	Finance	4010-0209-58007	
ENTERPRISE FM TRUST	2/23/2026	2600368	12/3/2025	FBN5515163	Lease Interest 26WVN2	197.44	Vehicle Replacement Fund	Finance	4010-0209-58005	
ENTERPRISE FM TRUST	2/23/2026	2600368	12/3/2025	FBN5515163	Lease Principal Dec 2025 277FMC	1,502.98	Vehicle Replacement Fund	Finance	4010-0209-58007	
ENTERPRISE FM TRUST	2/23/2026	2600368	12/3/2025	FBN5515163	Lease Interest 277FMC	203.72	Vehicle Replacement Fund	Finance	4010-0209-58005	
ENTERPRISE FM TRUST	2/23/2026	2600368	12/3/2025	FBN5515163	Lease Principal Dec 2025 278KJK	1,560.12	Vehicle Replacement Fund	Finance	4010-0209-58007	
ENTERPRISE FM TRUST	2/23/2026	2600368	12/3/2025	FBN5515163	Lease Interest 278KJK	235.24	Vehicle Replacement Fund	Finance	4010-0209-58005	
ENTERPRISE FM TRUST	2/23/2026	2600368	12/3/2025	FBN5515163	Lease Principal Dec 2025 286PW7	695.47	Vehicle Replacement Fund	Finance	4010-0209-58007	
ENTERPRISE FM TRUST	2/23/2026	2600368	12/3/2025	FBN5515163	Lease Interest 286PW7	132.40	Vehicle Replacement Fund	Finance	4010-0209-58005	
ENTERPRISE FM TRUST	2/23/2026	2600368	12/3/2025	FBN5515163	Lease Principal Dec 2025 28WC8T	337.01	Vehicle Replacement Fund	Finance	4010-0209-58007	
ENTERPRISE FM TRUST	2/23/2026	2600368	12/3/2025	FBN5515163	Lease Interest 28WC8T	61.66	Vehicle Replacement Fund	Finance	4010-0209-58005	
ENTERPRISE FM TRUST	2/23/2026	2600368	12/3/2025	FBN5515163	Lease Principal Dec 2025 27QFP5	1,347.13	Vehicle Replacement Fund	Finance	4010-0209-58007	
ENTERPRISE FM TRUST	2/23/2026	2600368	12/3/2025	FBN5515163	Lease Interest 27QFP5	245.00	Vehicle Replacement Fund	Finance	4010-0209-58005	
ENTERPRISE FM TRUST	2/23/2026	2600368	12/3/2025	FBN5515163	Lease Principal Dec 2025 28579J	940.86	Vehicle Replacement Fund	Finance	4010-0209-58007	

Bettendorf City Council AP Disbursements - 03.03.26

Vendor Name	Check Date	Check #	Invoice Date	Invoice #	Memo	Amount	Fund	Dept	Account #	Project
ENTERPRISE FM TRUST	2/23/2026	2600368	12/3/2025	FBN5515163	Lease Interest 28579J	167.90	Vehicle Replacement Fund	Finance	4010-0209-58005	
ENTERPRISE FM TRUST	2/23/2026	2600368	12/3/2025	FBN5515163	Lease Principal Dec 2025 27QFPF	1,415.21	Vehicle Replacement Fund	Finance	4010-0209-58007	
ENTERPRISE FM TRUST	2/23/2026	2600368	12/3/2025	FBN5515163	Lease Interest 27QFPF	302.42	Vehicle Replacement Fund	Finance	4010-0209-58005	
ENTERPRISE FM TRUST	2/23/2026	2600368	12/3/2025	FBN5515163	Lease Principal Dec 2025 29QCJ9	960.21	Vehicle Replacement Fund	Finance	4010-0209-58007	
ENTERPRISE FM TRUST	2/23/2026	2600368	12/3/2025	FBN5515163	Lease Interest 29QCJ9	216.45	Vehicle Replacement Fund	Finance	4010-0209-58005	
ENTERPRISE FM TRUST	1/20/2026	2600416	1/6/2026	FBN5530992	Lease Principal Jan 2026 26G59H	769.54	Vehicle Replacement Fund	Finance	4010-0209-58007	
ENTERPRISE FM TRUST	1/20/2026	2600416	1/6/2026	FBN5530992	Lease Interest 26G59H	-	Vehicle Replacement Fund	Finance	4010-0209-58005	
ENTERPRISE FM TRUST	1/20/2026	2600416	1/6/2026	FBN5530992	Lease Principal Jan 2026 26G5BG	815.68	Vehicle Replacement Fund	Finance	4010-0209-58007	
ENTERPRISE FM TRUST	1/20/2026	2600416	1/6/2026	FBN5530992	Lease Interest 26G5BG	-	Vehicle Replacement Fund	Finance	4010-0209-58005	
ENTERPRISE FM TRUST	1/20/2026	2600416	1/6/2026	FBN5530992	Lease Principal Jan 2026 26G5NF	1,339.15	Vehicle Replacement Fund	Finance	4010-0209-58007	
ENTERPRISE FM TRUST	1/20/2026	2600416	1/6/2026	FBN5530992	Lease Interest 26G5NF	53.22	Vehicle Replacement Fund	Finance	4010-0209-58005	
ENTERPRISE FM TRUST	1/20/2026	2600416	1/6/2026	FBN5530992	Lease Principal Jan 2026 26G5QP	1,523.80	Vehicle Replacement Fund	Finance	4010-0209-58007	
ENTERPRISE FM TRUST	1/20/2026	2600416	1/6/2026	FBN5530992	Lease Interest 26G5QP	102.26	Vehicle Replacement Fund	Finance	4010-0209-58005	
ENTERPRISE FM TRUST	1/20/2026	2600416	1/6/2026	FBN5530992	Lease Principal Jan 2026 26R3JM	1,487.59	Vehicle Replacement Fund	Finance	4010-0209-58007	
ENTERPRISE FM TRUST	1/20/2026	2600416	1/6/2026	FBN5530992	Lease Interest 26R3JM	95.37	Vehicle Replacement Fund	Finance	4010-0209-58005	
ENTERPRISE FM TRUST	1/20/2026	2600416	1/6/2026	FBN5530992	Lease Principal Jan 2026 26R3K7	1,590.86	Vehicle Replacement Fund	Finance	4010-0209-58007	
ENTERPRISE FM TRUST	1/20/2026	2600416	1/6/2026	FBN5530992	Lease Interest 26R3K7	101.99	Vehicle Replacement Fund	Finance	4010-0209-58005	
ENTERPRISE FM TRUST	1/20/2026	2600416	1/6/2026	FBN5530992	Lease Principal Jan 2026 22K3R	1,589.84	Vehicle Replacement Fund	Finance	4010-0209-58007	
ENTERPRISE FM TRUST	1/20/2026	2600416	1/6/2026	FBN5530992	Lease Interest 22K3R	101.93	Vehicle Replacement Fund	Finance	4010-0209-58005	
ENTERPRISE FM TRUST	1/20/2026	2600416	1/6/2026	FBN5530992	Lease Principal Jan 2026 26ZK4S	1,598.19	Vehicle Replacement Fund	Finance	4010-0209-58007	
ENTERPRISE FM TRUST	1/20/2026	2600416	1/6/2026	FBN5530992	Lease Interest 26ZK4S	102.46	Vehicle Replacement Fund	Finance	4010-0209-58005	
ENTERPRISE FM TRUST	1/20/2026	2600416	1/6/2026	FBN5530992	Lease Principal Jan 2026 26G89T	1,524.99	Vehicle Replacement Fund	Finance	4010-0209-58007	
ENTERPRISE FM TRUST	1/20/2026	2600416	1/6/2026	FBN5530992	Lease Interest 26G89T	128.84	Vehicle Replacement Fund	Finance	4010-0209-58005	
ENTERPRISE FM TRUST	1/20/2026	2600416	1/6/2026	FBN5530992	Lease Principal Jan 2026 275WN3	1,151.35	Vehicle Replacement Fund	Finance	4010-0209-58007	
ENTERPRISE FM TRUST	1/20/2026	2600416	1/6/2026	FBN5530992	Lease Interest 275WN3	105.09	Vehicle Replacement Fund	Finance	4010-0209-58005	
ENTERPRISE FM TRUST	1/20/2026	2600416	1/6/2026	FBN5530992	Lease Principal Jan 2026 26G5PJ	1,383.42	Vehicle Replacement Fund	Finance	4010-0209-58007	
ENTERPRISE FM TRUST	1/20/2026	2600416	1/6/2026	FBN5530992	Lease Interest 26G5PJ	118.78	Vehicle Replacement Fund	Finance	4010-0209-58005	
ENTERPRISE FM TRUST	1/20/2026	2600416	1/6/2026	FBN5530992	Lease Principal Jan 2026 26GXV7	1,481.97	Vehicle Replacement Fund	Finance	4010-0209-58007	
ENTERPRISE FM TRUST	1/20/2026	2600416	1/6/2026	FBN5530992	Lease Interest 26GXV7	127.24	Vehicle Replacement Fund	Finance	4010-0209-58005	
ENTERPRISE FM TRUST	1/20/2026	2600416	1/6/2026	FBN5530992	Lease Principal Jan 2026 273JSZ	1,056.21	Vehicle Replacement Fund	Finance	4010-0209-58007	
ENTERPRISE FM TRUST	1/20/2026	2600416	1/6/2026	FBN5530992	Lease Interest 273JSZ	101.86	Vehicle Replacement Fund	Finance	4010-0209-58005	
ENTERPRISE FM TRUST	1/20/2026	2600416	1/6/2026	FBN5530992	Lease Principal Jan 2026 273JWI	1,062.72	Vehicle Replacement Fund	Finance	4010-0209-58007	
ENTERPRISE FM TRUST	1/20/2026	2600416	1/6/2026	FBN5530992	Lease Interest 273JWI	102.49	Vehicle Replacement Fund	Finance	4010-0209-58005	
ENTERPRISE FM TRUST	1/20/2026	2600416	1/6/2026	FBN5530992	Lease Principal Jan 2026 26WVN2	1,445.98	Vehicle Replacement Fund	Finance	4010-0209-58007	
ENTERPRISE FM TRUST	1/20/2026	2600416	1/6/2026	FBN5530992	Lease Interest 26WVN2	189.01	Vehicle Replacement Fund	Finance	4010-0209-58005	
ENTERPRISE FM TRUST	1/20/2026	2600416	1/6/2026	FBN5530992	Lease Principal Jan 2026 277FMC	1,511.31	Vehicle Replacement Fund	Finance	4010-0209-58007	
ENTERPRISE FM TRUST	1/20/2026	2600416	1/6/2026	FBN5530992	Lease Interest 277FMC	195.39	Vehicle Replacement Fund	Finance	4010-0209-58005	
ENTERPRISE FM TRUST	1/20/2026	2600416	1/6/2026	FBN5530992	Lease Principal Jan 2026 278KJK	1,569.67	Vehicle Replacement Fund	Finance	4010-0209-58007	
ENTERPRISE FM TRUST	1/20/2026	2600416	1/6/2026	FBN5530992	Lease Interest 278KJK	225.69	Vehicle Replacement Fund	Finance	4010-0209-58005	
ENTERPRISE FM TRUST	1/20/2026	2600416	1/6/2026	FBN5530992	Lease Principal Jan 2026 286PW7	699.98	Vehicle Replacement Fund	Finance	4010-0209-58007	
ENTERPRISE FM TRUST	1/20/2026	2600416	1/6/2026	FBN5530992	Lease Interest 286PW7	127.89	Vehicle Replacement Fund	Finance	4010-0209-58005	
ENTERPRISE FM TRUST	1/20/2026	2600416	1/6/2026	FBN5530992	Lease Principal Jan 2026 28WC8T	339.12	Vehicle Replacement Fund	Finance	4010-0209-58007	
ENTERPRISE FM TRUST	1/20/2026	2600416	1/6/2026	FBN5530992	Lease Interest 28WC8T	59.55	Vehicle Replacement Fund	Finance	4010-0209-58005	
ENTERPRISE FM TRUST	1/20/2026	2600416	1/6/2026	FBN5530992	Lease Principal Jan 2026 27QFP5	1,355.49	Vehicle Replacement Fund	Finance	4010-0209-58007	
ENTERPRISE FM TRUST	1/20/2026	2600416	1/6/2026	FBN5530992	Lease Interest 27QFP5	236.64	Vehicle Replacement Fund	Finance	4010-0209-58005	
ENTERPRISE FM TRUST	1/20/2026	2600416	1/6/2026	FBN5530992	Lease Principal Jan 2026 28579J	946.60	Vehicle Replacement Fund	Finance	4010-0209-58007	
ENTERPRISE FM TRUST	1/20/2026	2600416	1/6/2026	FBN5530992	Lease Interest 28579J	162.16	Vehicle Replacement Fund	Finance	4010-0209-58005	
ENTERPRISE FM TRUST	1/20/2026	2600416	1/6/2026	FBN5530992	Lease Principal Jan 2026 27QFPF	1,424.07	Vehicle Replacement Fund	Finance	4010-0209-58007	
ENTERPRISE FM TRUST	1/20/2026	2600416	1/6/2026	FBN5530992	Lease Interest 27QFPF	293.56	Vehicle Replacement Fund	Finance	4010-0209-58005	
ENTERPRISE FM TRUST	1/20/2026	2600416	1/6/2026	FBN5530992	Lease Principal Jan 2026 29QCJ9	965.80	Vehicle Replacement Fund	Finance	4010-0209-58007	
ENTERPRISE FM TRUST	1/20/2026	2600416	1/6/2026	FBN5530992	Lease Interest 29QCJ9	210.86	Vehicle Replacement Fund	Finance	4010-0209-58005	
ENTERPRISE FM TRUST	1/20/2026	2600416	1/6/2026	FBN5530992	Lease Principal Jan 2026 29W9QQ	1,561.84	Vehicle Replacement Fund	Finance	4010-0209-58007	
ENTERPRISE FM TRUST	1/20/2026	2600416	1/6/2026	FBN5530992	Lease Interest 29W9QQ	8.10	Vehicle Replacement Fund	Finance	4010-0209-58005	
ENTERPRISE FM TRUST	2/23/2026	2600368	12/3/2025	FBN5515163	Lease Inception Expenditure	-	Vehicle Replacement Fund	Finance	4010-0242-57090	
ENTERPRISE FM TRUST	1/20/2026	2600416	1/6/2026	FBN5530992	Lease Inception Expenditure	11,435.00	Vehicle Replacement Fund	Finance	4010-0242-57090	
RELIANT FIRE APPARATUS, INC	2/18/2026	133084	1/26/2026	126-23076	New fire truck Pierce Enforcer	771,042.23	Vehicle Replacement Fund	Finance	4010-0242-57074	
PLASTIX PLUS	2/25/2026	133108	2/19/2026	24594	Brackets, Console Organizer, Cargo Box (New Engine 1)	1,562.59	Vehicle Replacement Fund	Finance	4010-0242-57074	Engine 1 Replacement - 2026
						<b>849,056.52</b>	<b>Vehicle Replacement Fund Total</b>			
BERRYDUNN	2/18/2026	133075	11/1/2025	470307	CO #2 - Implementation costs (per BD, move unused ERP selection costs to implementation),	225.00	Technology Replacement	Finance	4020-0243-57074	
BERRYDUNN	2/18/2026	133075	11/1/2025	472306	CO #2 - Implementation costs (per BD, move unused ERP selection costs to implementation),	675.00	Technology Replacement	Finance	4020-0243-57074	

Bettendorf City Council AP Disbursements - 03.03.26

Vendor Name	Check Date	Check #	Invoice Date	Invoice #	Memo	Amount	Fund	Dept	Account #	Project
BERRYDUNN	2/18/2026	133075	11/1/2025	465363	CO #2 - Implementation costs (per BD, move unused ERP selection costs to implementation)	1,800.00	Technology Replacement	Finance	4020-0243-57074	
BERRYDUNN	2/18/2026	133075	11/1/2025	469002	CO #2 - Implementation costs (per BD, move unused ERP selection costs to implementation)	2,025.00	Technology Replacement	Finance	4020-0243-57074	
BERRYDUNN	2/18/2026	133075	11/1/2025	463499	CO #2 - Implementation costs (per BD, move unused ERP selection costs to implementation)	2,250.00	Technology Replacement	Finance	4020-0243-57074	
BERRYDUNN	2/18/2026	133075	11/1/2025	467408	CO #2 - Implementation costs (per BD, move unused ERP selection costs to implementation)	3,037.50	Technology Replacement	Finance	4020-0243-57074	
BERRYDUNN	2/18/2026	133075	11/1/2025	461544	CO #2 - Implementation costs (per BD, move unused ERP selection costs to implementation)	4,837.50	Technology Replacement	Finance	4020-0243-57074	
MOORING TECH	2/25/2026	133106	1/21/2026	89924	Win11 Pro, Intel Core i5-1345U vPro (up to 4.7GHz), AMT, 14.0 FHD 1000 nit Gloved Multi Touch	129,500.00	Technology Replacement	Finance	4020-0243-56004	
UKG KRONOS SYSTEMS	3/4/2026	133209	2/20/2026	110080046021	UKG PAYROLL	3,500.00	Technology Replacement	Finance	4020-0243-57074	
						<b>147,850.00</b>	<b>Technology Replacement Total</b>			
					MONTHLY RETURN DEC					
TREASURER, STATE OF IOWA	2/23/2026	2600371	12/31/2025	123125		10,314.06	Sewer Utility	Balance Sheet	5200-0000-20401	
					BK DISCHARGE TAVERAS TYUS	37.68	Sewer Utility	Balance Sheet	5200-0000-11013	
MUNICIPAL COLLECTIONS OF AMERICA	3/4/2026	133176	1/31/2026	72572						
MERCHANT SERVICES	2/23/2026	2600367	11/30/2025	1125	Bankcard fees ut,sw1 ,sw2	2,323.19	Sewer Utility	Finance	5200-0204-55032	
					BK DISCHARGE TAVERAS TYUS	(37.68)	Sewer Utility	Finance	5200-0204-55004	
MUNICIPAL COLLECTIONS OF AMERICA	3/4/2026	133176	1/31/2026	72572						
MUNICIPAL COLLECTIONS OF AMERICA	3/4/2026	133176	1/31/2026	72572	MCOA FEES 01/1-01/31/2026	16.16	Sewer Utility	Finance	5200-0204-55081	
AUTHORIZE.NET	2/3/2026	2600426	1/31/2026	126	online pymt gateway	30.00	Sewer Utility	Finance	5200-0204-55032	
BAKER TILLY MUNICIPAL ADVISORS,LLC	2/18/2026	133074	2/10/2026	BT3489813	Sanitary Sewer Rate Study	15,000.00	Sewer Utility	Finance	5200-0204-55081	
ALTORFER RENTS	3/4/2026	133118	1/29/2026	WO400050103	Esca Registration	3,130.00	Sewer Utility	Public Works	5200-0510-55081	
CITY OF DAVENPORT	3/4/2026	133129	2/18/2026	1339691	January 2026 Sewage Treatment Plant	162,510.12	Sewer Utility	Public Works	5200-0510-55013	
STIVERS FORD	3/4/2026	133199	1/19/2026	F63092	2026 Ford F-550 Crew Cab - Sewer	62,547.00	Sewer Utility	Public Works	5200-0599-57074	
TRUCK EQUIPMENT INC.	3/4/2026	133208	2/14/2026	89774	Dump Box, Snowplow, Boom Crane - Sewer F-550	55,403.40	Sewer Utility	Public Works	5200-0599-57074	
DAVENPORT ELECTRIC CONTRACT	3/4/2026	133133	2/19/2026	59633	Spencer Hollow Lift Station Removal	4,687.50	Sewer Utility	Capital Projects	5200-5059-55081	Spencer Creek Lift Statn
						<b>315,961.43</b>	<b>Sewer Utility Total</b>			
					MONTHLY RETURN DEC					
TREASURER, STATE OF IOWA	2/23/2026	2600371	12/31/2025	123125		141.66	Solid Waste/Recycling Ent	Balance Sheet	5500-0000-20401	
					BK DISCHARGE TAVERAS TYUS	26.44	Solid Waste/Recycling Ent	Balance Sheet	5500-0000-11013	
MUNICIPAL COLLECTIONS OF AMERICA	3/4/2026	133176	1/31/2026	72572						
MERCHANT SERVICES	2/23/2026	2600367	11/30/2025	1125	Bankcard fees recycle, sw1 ,sw2, 50% pw	2,345.49	Solid Waste/Recycling Ent	Finance	5500-0216-55032	
					BK DISCHARGE TAVERAS TYUS	(26.44)	Solid Waste/Recycling Ent	Finance	5500-0216-55004	
MUNICIPAL COLLECTIONS OF AMERICA	3/4/2026	133176	1/31/2026	72572						
MUNICIPAL COLLECTIONS OF AMERICA	3/4/2026	133176	1/31/2026	72572	MCOA FEES 01/1-01/31/2026	11.34	Solid Waste/Recycling Ent	Finance	5500-0216-55081	
DAVENPORT PRINTING COMPANY	3/4/2026	133134	12/23/2025	253722	Additional costs - annual calendar mailings	150.00	Solid Waste/Recycling Ent	Public Works	5500-0506-56007	
						<b>2,648.49</b>	<b>Solid Waste/Recycling Ent Total</b>			
KONE INC.	3/4/2026	133160	2/1/2026	871927787	Quarterly Maintenance	245.17	Family Museum	Public Works	5550-0523-54001	Fam Museum Maint FY25/26
JOHNSON CONTROLS SECURITY SOLUTIONS	3/4/2026	133155	2/7/2026	42151175	Annual Alarm Monitoring contract	3,193.32	Family Museum	Public Works	5550-0523-54001	Fam Museum Maint FY25/26
DOORS INC.	3/4/2026	133136	2/18/2026	371445	Rekey Lock Cylinders	76.00	Family Museum	Public Works	5550-0523-54001	Fam Museum Maint FY25/26
WORLDPAY	2/5/2026	2600424	1/31/2026	126	Bankcard Fees Museum	2,288.35	Family Museum	Family Museum	5550-1101-55032	
VESTIS	3/4/2026	133212	2/18/2026	6150681935	Museum - First Aid Supplies	59.96	Family Museum	Family Museum	5550-1101-56007	
JIM GILL, INC.	3/4/2026	133152	1/19/2026	7370	Museum - Spring Break Performance March 20th	2,000.00	Family Museum	Family Museum	5550-1102-56007	
ANIKA KUMAR	3/4/2026	133121	2/10/2026	21026	Museum - Art Academy Assistant February 1-14	12.50	Family Museum	Family Museum	5550-1102-56007	
DELANEY CARROLL	3/4/2026	133135	2/10/2026	21026	Museum - Art Academy Assistant February 1-14	70.00	Family Museum	Family Museum	5550-1102-56007	
MYERS PRODUCTIONS	3/4/2026	133177	2/11/2026	02112026A	Museum - Spring Break Performance 3.17.26	200.00	Family Museum	Family Museum	5550-1102-56007	
AMBER STEPHENS	3/4/2026	133119	2/11/2026	21126	Museum - Refund for overpayment of class cancelled	85.00	Family Museum	Family Museum	5550-1102-56013	
NATIONAL MISSISSIPPI RIVER MUSEUM & AQUARIU	3/4/2026	133179	2/12/2026	12125996	Museum - Spring Break Guest 3.19.26	327.20	Family Museum	Family Museum	5550-1102-56007	
PUTNAM MUSEUM OF HISTORY &	3/4/2026	133186	2/18/2026	12302705	Museum - Spring Break Discovery Dome	602.70	Family Museum	Family Museum	5550-1102-56007	
LOGO PRO, LLC	3/4/2026	133168	2/17/2026	28858	Museum - Logo Table Covers	431.00	Family Museum	Family Museum	5550-1105-55002	
						<b>9,591.20</b>	<b>Family Museum Total</b>			
ALL BRAND COMPRESSOR SERVICE	2/25/2026	133098	1/1/2026	749017	Pressure Switch	65.00	Palmer Hills Golf Course	Public Works	5600-0523-54001	PHGC Maint FY25/26
ALL BRAND COMPRESSOR SERVICE	2/25/2026	133098	1/1/2026	62672	Pressure Switch - Sprinkler System	65.00	Palmer Hills Golf Course	Public Works	5600-0523-54001	PHGC Maint FY25/26
MERCHANT SERVICES	2/23/2026	2600367	11/30/2025	1125	Bankcard fees Golf range balls	271.88	Palmer Hills Golf Course	Parks & Recreation	5600-0711-55032	
M & M GOLF CARS LLC	3/4/2026	133169	1/22/2026	306954	Club Car BN2532676599 Windshield Replacement	215.78	Palmer Hills Golf Course	Parks & Recreation	5600-0711-54006	
ALEX GRELL	2/18/2026	133073	1/23/2026	260123	2026 PGA Show Travel Reimbursement	1,494.11	Palmer Hills Golf Course	Parks & Recreation	5600-0711-53004	
					2026 PGA Show Reimbursement					
JON WADDELL	2/18/2026	133080	1/23/2026	260123		1,630.07	Palmer Hills Golf Course	Parks & Recreation	5600-0711-53004	
A & A/C & REFRIGERATION, INC.	3/4/2026	133115	1/31/2026	26JAN01492	January Ice Machine Rental	175.00	Palmer Hills Golf Course	Parks & Recreation	5600-0711-55015	The Forge Putting Course
VESTIS	3/4/2026	133212	2/6/2026	6150676615	First Aid Service	25.00	Palmer Hills Golf Course	Parks & Recreation	5600-0711-56010	

Bettendorf City Council AP Disbursements - 03.03.26

Vendor Name	Check Date	Check #	Invoice Date	Invoice #	Memo	Amount	Fund	Dept	Account #	Project
VESTIS	3/4/2026	133212	2/13/2026	6150679903	First Aid Service	25.00	Palmer Hills Golf Course	Parks & Recreation	5600-0711-56010	
BRIAN HICKEY	3/4/2026	133125	2/1/2026	260201	2026 GCSAA Conference Reimbursement - Travel	65.97	Palmer Hills Golf Course	Parks & Recreation	5600-0715-53004	
BRIAN HICKEY	3/4/2026	133125	2/5/2026	260205	2026 GCSAA Conference Reimbursement - Travel	36.06	Palmer Hills Golf Course	Parks & Recreation	5600-0715-53004	
VESTIS	3/4/2026	133212	2/6/2026	6150676613	First Aid Service	29.98	Palmer Hills Golf Course	Parks & Recreation	5600-0715-56010	
VESTIS	3/4/2026	133212	2/6/2026	6150676612	Laundry Services	44.15	Palmer Hills Golf Course	Parks & Recreation	5600-0715-55081	
VESTIS	3/4/2026	133212	2/13/2026	6150679901	First Aid Service	29.98	Palmer Hills Golf Course	Parks & Recreation	5600-0715-56010	
VESTIS	3/4/2026	133212	2/13/2026	6150679900	Laundry Services	62.35	Palmer Hills Golf Course	Parks & Recreation	5600-0715-55081	
						<b>4,235.33</b>	<b>Palmer Hills Golf Course Total</b>			
					MONTHLY RETURN DEC					
TREASURER, STATE OF IOWA	2/23/2026	2600371	12/31/2025	123125		11,433.18	Storm Water Utility	Balance Sheet	5800-0000-20401	
					BK DISCHARGE TAVERAS TYUS	7.99	Storm Water Utility	Balance Sheet	5800-0000-11013	
MUNICIPAL COLLECTIONS OF AMERICA	3/4/2026	133176	1/31/2026	72572						
					Bankcard fees storm wtr_sw1_sw2	2,323.19	Storm Water Utility	Finance	5800-0219-55032	
MERCHANT SERVICES	2/23/2026	2600367	11/30/2025	1125						
					BK DISCHARGE TAVERAS TYUS	(7.99)	Storm Water Utility	Finance	5800-0219-55004	
MUNICIPAL COLLECTIONS OF AMERICA	3/4/2026	133176	1/31/2026	72572	MCOA FEES 01/1-01/31/2026	3.43	Storm Water Utility	Finance	5800-0219-55081	
MUNICIPAL COLLECTIONS OF AMERICA	3/4/2026	133176	1/31/2026	72572						
SCOTT COUNTY RECORDER	3/4/2026	133197	2/1/2026	2026-001185	Easements for Pigeon Creek 2025-25116 to 251222026-001185	22.00	Storm Water Utility	Capital Projects	5800-5059-55005	WHITE POST RD STORM REP
						<b>13,781.80</b>	<b>Storm Water Utility Total</b>			
RIVER BEND TRANSIT	2/18/2026	133085	1/31/2026	013126WS	Fares collected - January 2026	(25.50)	Transit	Public Works	5850-0500-47232	
MERCHANT SERVICES	2/23/2026	2600367	11/30/2025	1125	Bankcard fees 50% pw	22.31	Transit	Public Works	5850-0507-55032	
RIVER BEND TRANSIT	2/18/2026	133085	1/31/2026	013126WS	Weekday Service - January 2026	3,271.19	Transit	Public Works	5850-0507-55029	
JL BRADY COMPANY LLC	3/4/2026	133153	2/10/2026	123975	Bus Wash Water Line Repair	665.25	Transit	Public Works	5850-0547-54006	
RAYNOR DOOR CO., INC. OF THE QC	3/4/2026	133189	2/11/2026	150721	Bus Wash Doors Adjustments	345.00	Transit	Public Works	5850-0547-54006	
						<b>4,278.25</b>	<b>Transit Total</b>			
THE GREEN THUMBERS	3/4/2026	133204	2/2/2026	1-886660	plant maint	325.00	QC Waterfront Convention	QC Waterfront Conv Ctr	5900-2001-55081	
						<b>325.00</b>	<b>QC Waterfront Convention Total</b>			
MHC KENWORTH	2/25/2026	133105	1/1/2026	T01135600227072	Fitting	23.66	Municipal Garage	Public Works	6830-0520-56007	
ELLIOTT EQUIPMENT CO.	3/4/2026	133140	1/1/2026	127858	Fuel Tank	3,320.06	Municipal Garage	Public Works	6830-0520-56024	
KILBURG EQUIPMENT, LLC.	2/25/2026	133102	1/20/2026	7126	grabber assembly - 2400	7,169.33	Municipal Garage	Public Works	6830-0520-56024	
S J SMITH CO. INC.	3/4/2026	133195	1/31/2026	842924	Operating Supplies	206.15	Municipal Garage	Public Works	6830-0520-56007	
JOHNSON OIL COMPANY	3/4/2026	133157	2/1/2026	11232798	Fuel 4133	23.92	Municipal Garage	Public Works	6830-0520-56035	
LINDQUIST FORD, INC.	3/4/2026	133166	2/2/2026	295009	Misfire Repair	1,111.65	Municipal Garage	Public Works	6830-0520-54004	
KILBURG EQUIPMENT, LLC.	2/18/2026	133081	2/5/2026	7181	Floor for 1611 - Recycle Truck	9,167.00	Municipal Garage	Public Works	6830-0520-54004	
MACQUEEN EQUIPMENT, LLC	3/4/2026	133170	2/5/2026	P29947	STK Filter	411.90	Municipal Garage	Public Works	6830-0520-56024	
KILBURG EQUIPMENT, LLC.	3/4/2026	133158	2/5/2026	7182	E-Stop Switch	340.32	Municipal Garage	Public Works	6830-0520-56024	
TERMINAL SUPPLY COMPANY	3/4/2026	133201	2/5/2026	88017-00	Operating Supplies	141.20	Municipal Garage	Public Works	6830-0520-56007	
ASCENDANCE TRUCKS LLC	3/4/2026	133122	2/6/2026	XA353007179:01	STK Filter	67.55	Municipal Garage	Public Works	6830-0520-56024	
MARTIN EQUIPMENT OF ILLINOIS, INC.	3/4/2026	133171	2/6/2026	952150	Battery Harness	276.91	Municipal Garage	Public Works	6830-0520-56024	
MHC KENWORTH	3/4/2026	133173	2/6/2026	T01135600228801	STK Filter	39.61	Municipal Garage	Public Works	6830-0520-56024	
MHC KENWORTH	3/4/2026	133173	2/6/2026	T01135600228800	STK Filters	122.94	Municipal Garage	Public Works	6830-0520-56024	
ASCENDANCE TRUCKS LLC	3/4/2026	133122	2/7/2026	XA353007199:01	Sensor - Engine 4 2408	95.13	Municipal Garage	Public Works	6830-0520-56024	
ASCENDANCE TRUCKS LLC	3/4/2026	133122	2/9/2026	XA353007205:01	Clamp - 2010	81.66	Municipal Garage	Public Works	6830-0520-56024	
I.W.I. MOTOR PARTS	3/4/2026	133149	2/9/2026	442355036	Oil and Filter	99.86	Municipal Garage	Public Works	6830-0520-56024	
MACQUEEN EQUIPMENT, LLC	3/4/2026	133170	2/9/2026	P29969	STK Filter	1,076.83	Municipal Garage	Public Works	6830-0520-56024	
EASTERN IOWA TIRE, INC.	3/4/2026	133138	2/9/2026	100186424	STK Tires	2,021.76	Municipal Garage	Public Works	6830-0520-56024	
EASTERN IOWA TIRE, INC.	3/4/2026	133138	2/9/2026	100186427	STK Tires	2,045.79	Municipal Garage	Public Works	6830-0520-56024	
ELLIOTT EQUIPMENT CO.	3/4/2026	133140	2/9/2026	191598	Valve STK	249.75	Municipal Garage	Public Works	6830-0520-56024	
ELLIOTT EQUIPMENT CO.	3/4/2026	133140	2/9/2026	191604	Seat 1612	1,340.61	Municipal Garage	Public Works	6830-0520-56024	
ALEXIS FIRE EQUIPMENT COMPANY	3/4/2026	133117	2/10/2026	0078994-IN	Sensor 1919	201.60	Municipal Garage	Public Works	6830-0520-56024	
MIDWEST WHEEL COMPANIES INC.	3/4/2026	133175	2/10/2026	4515344-00	Light	61.62	Municipal Garage	Public Works	6830-0520-56024	
HENDERSON PRODUCTS	3/4/2026	133148	2/10/2026	441434	Stroke 2008	242.41	Municipal Garage	Public Works	6830-0520-56024	
ASCENDANCE TRUCKS LLC	3/4/2026	133122	2/11/2026	XA353007296:01	STK Filters	199.86	Municipal Garage	Public Works	6830-0520-56024	
LAWSON PRODUCTS, INC.	3/4/2026	133163	2/11/2026	9313210710	Operating Supplies	48.11	Municipal Garage	Public Works	6830-0520-56007	
PLEASANT VALLEY COMMUNITY	3/4/2026	133183	2/11/2026	26-145	Fuel	26,027.85	Municipal Garage	Public Works	6830-0520-56035	
TERMINAL SUPPLY COMPANY	3/4/2026	133201	2/11/2026	89218-00	STK Lights	173.60	Municipal Garage	Public Works	6830-0520-56024	
INTERSTATE BATTERY OF THE	3/4/2026	133150	2/11/2026	298251	STK Battery	682.94	Municipal Garage	Public Works	6830-0520-56024	
MHC KENWORTH	3/4/2026	133173	2/12/2026	T01135600229027	Filters STK	187.10	Municipal Garage	Public Works	6830-0520-56024	
SAFETY VISION INC	3/4/2026	133196	2/12/2026	INV27887	Camera	395.24	Municipal Garage	Public Works	6830-0520-56024	
ASCENDANCE TRUCKS LLC	3/4/2026	133122	2/13/2026	RA353002357:01	EGR Repair 1629	3,672.79	Municipal Garage	Public Works	6830-0520-54004	
NOTT COMPANY	3/4/2026	133180	2/13/2026	5447021-00	Hose 1801	360.90	Municipal Garage	Public Works	6830-0520-56024	
MHC KENWORTH	3/4/2026	133173	2/13/2026	T01135600229067	Pressure Sensor STK	208.45	Municipal Garage	Public Works	6830-0520-56024	
I.W.I. MOTOR PARTS	3/4/2026	133149	2/17/2026	431-192940	Radiator 0513	405.89	Municipal Garage	Public Works	6830-0520-56024	
EASTERN IOWA TIRE, INC.	3/4/2026	133138	2/17/2026	100186698	Tires STK	2,580.15	Municipal Garage	Public Works	6830-0520-56024	

Bettendorf City Council AP Disbursements - 03.03.26

Vendor Name	Check Date	Check #	Invoice Date	Invoice #	Memo	Amount	Fund	Dept	Account #	Project
GREEN BUICK GMC INC.	3/4/2026	133147	2/17/2026	167310	Cooler Lines	296.44	Municipal Garage	Public Works	6830-0520-56024	
MIDWEST WHEEL COMPANIES INC.	3/4/2026	133175	2/18/2026	4527629-00	Air Dryer Filter	209.98	Municipal Garage	Public Works	6830-0520-56024	
RILCO FLUID CARE, INC.	3/4/2026	133191	2/18/2026	595440	DEF Fuel	328.90	Municipal Garage	Public Works	6830-0520-56035	
KILBURG EQUIPMENT, LLC.	3/4/2026	133158	2/18/2026	7212	Floor and Pin Repair 1801	1,500.00	Municipal Garage	Public Works	6830-0520-54004	
INTERSTATE BATTERY OF THE	3/4/2026	133150	2/18/2026	10069584	STk Battery	228.15	Municipal Garage	Public Works	6830-0520-56024	
MIDWEST WHEEL COMPANIES INC.	3/4/2026	133175	2/19/2026	4529455-00	Hose 1629	15.89	Municipal Garage	Public Works	6830-0520-56024	
LINDQUIST FORD, INC.	3/4/2026	133166	2/23/2026	393995	Oil Plug STK	839.34	Municipal Garage	Public Works	6830-0520-56024	
						<b>68,300.80</b>	<b>Municipal Garage Total</b>			
IOWA COMMUNITIES ASSURANCE POOL	2/18/2026	133078	2/13/2026	040555-001861-AD-01	Claim # 040555-001861-AD-01	3,604.47	Risk Management	Mayor & Council	6840-0105-55050	
						<b>3,604.47</b>	<b>Risk Management Total</b>			
WELLMARK BLUE CROSS & BLUE SHIELD	2/23/2026	2600366	11/30/2025	113025	Admin fees Nov	15,469.47	Employee Insurance	Mayor & Council	6860-0106-55065	
WELLMARK BLUE CROSS & BLUE SHIELD	2/23/2026	2600366	11/30/2025	113025	Medical claims, 11/22-11/30/25	136,557.20	Employee Insurance	Mayor & Council	6860-0106-55063	
WELLMARK BLUE CROSS & BLUE SHIELD	2/23/2026	2600366	11/30/2025	113025	Pharmacy Claims Nov	(99,574.88)	Employee Insurance	Mayor & Council	6860-0106-55080	
WELLMARK BLUE CROSS & BLUE SHIELD	2/23/2026	2600366	11/30/2025	113025	Pharmacy Claims Nov	99,574.88	Employee Insurance	Mayor & Council	6860-0106-55063	
WAGEWORKS	2/23/2026	2600370	12/23/2025	INV8556382	Benefit Period - Dec 2025, Admin fees, INV8556382	296.25	Employee Insurance	Mayor & Council	6860-0106-55065	
					Medical claims, 01/10-01/16/2026					
WELLMARK BLUE CROSS & BLUE SHIELD	1/23/2026	2600415	1/16/2026	1162026		104,825.15	Employee Insurance	Mayor & Council	6860-0106-55063	
DELTA DENTAL	1/26/2026	2600418	1/19/2026	35205000000202600	DENTAL CLAIMS 01/13-01/19/2026	3,532.67	Employee Insurance	Mayor & Council	6860-0106-55076	
					Medical claims, 01/17-01/23/2026					
WELLMARK BLUE CROSS & BLUE SHIELD	1/30/2026	2600419	1/23/2026	12326		93,891.42	Employee Insurance	Mayor & Council	6860-0106-55063	
WAGEWORKS	2/23/2026	2600433	1/23/2026	INV8649259	Benefit Period - JAN 2026, Admin fees, INV8649259	296.25	Employee Insurance	Mayor & Council	6860-0106-55065	
DELTA DENTAL	2/2/2026	2600423	1/26/2026	35205000000202600	DENTAL CLAIMS 01/20-01/26/2026	10,068.75	Employee Insurance	Mayor & Council	6860-0106-55076	
					Vision claims cks 2900 - 2907					
EMPLOYEE BENEFIT SYSTEM	1/29/2026	2600422	1/28/2026	12826		2,716.86	Employee Insurance	Mayor & Council	6860-0106-55078	
DELTA DENTAL	2/9/2026	2600428	2/2/2026	35205000000202600	DENTAL CLAIMS 01/27-02/02/2026	8,888.92	Employee Insurance	Mayor & Council	6860-0106-55076	
					Vision claims cks 2908 - 2912					
EMPLOYEE BENEFIT SYSTEM	2/5/2026	2600427	2/4/2026	2042026		1,189.80	Employee Insurance	Mayor & Council	6860-0106-55078	
					Medical claims, 02/01-02/06/2026					
WELLMARK BLUE CROSS & BLUE SHIELD	2/13/2026	2600429	2/6/2026	2062026		78,496.31	Employee Insurance	Mayor & Council	6860-0106-55063	
DELTA DENTAL	2/17/2026	2600432	2/9/2026	35205000000202600	DENTAL CLAIMS 02/03-02/09/2026	4,498.75	Employee Insurance	Mayor & Council	6860-0106-55076	
					Vision claim cks 2913-2915					
EMPLOYEE BENEFIT SYSTEM	2/12/2026	2600431	2/11/2026	21126		423.76	Employee Insurance	Mayor & Council	6860-0106-55078	
YMCA OF IOWA MISSISSIPPI VALLEY	3/4/2026	133214	2/12/2026	2/2026-BETT	February 2026 employee monthly membership billing, INV 2/2026-BETT	2,660.00	Employee Insurance	Mayor & Council	6860-0106-55079	
EMPLOYEE BENEFIT SYSTEM	3/4/2026	133141	2/18/2026	52024	March 2026 Employee Monthly Billing, INV 52024	882.18	Employee Insurance	Mayor & Council	6860-0106-55065	
						<b>464,693.74</b>	<b>Employee Insurance Total</b>			
					15 Months of Tenant Manager. 1 Year subscription with additional 3 months to align billing times with Robopack.	1,395.36	Information Services	Finance	6880-0231-55023	IT - Finance
SOFTWARECENTRAL A/S	2/23/2026	2600369	12/22/2025	27863						
US SIGNAL COMPANY	3/4/2026	133210	2/11/2026	BD0095921	Cisco phone maintenance subscription	1,052.50	Information Services	Finance	6880-0231-55023	IT - Information Technology
TRAFFIC LOGIX CORPORATION	3/4/2026	133206	2/11/2026	SIN35647	Annual Cloud Service for School Speed Signs	9,900.00	Information Services	Finance	6880-0231-55023	IT - Police
						<b>12,347.86</b>	<b>Information Services Total</b>			
IPERS COLLECTIONS	1/9/2026	2600384	1/9/2026	121226865	EMPLOYEE SHARE IPERS	41,056.29	Liability Clearing Acct.	Balance Sheet	8100-0000-21010	
IPERS COLLECTIONS	1/9/2026	2600384	1/9/2026	121226865	CITY SHARE IPERS	61,617.09	Liability Clearing Acct.	Balance Sheet	8100-0000-21010	
GREAT AMERICAN PLAN ADMINISTRATORS	1/9/2026	2600385	1/9/2026	PR 01.09.26 GREAT AMERICAN	01/09/25 PR CONTRIBUTIONS	569.04	Liability Clearing Acct.	Balance Sheet	8100-0000-21020	
IOWA DEPARTMENT OF REVENUE	1/9/2026	2600372	1/9/2026	0-009-733-840	01/09/26 PAY DATE IA W/H TAX	25,645.13	Liability Clearing Acct.	Balance Sheet	8100-0000-21006	
COLLECTION SERVICES CENTER	1/9/2026	2600373	1/9/2026	2699826	CHILD/SPOUSE SUPPORT	1,681.24	Liability Clearing Acct.	Balance Sheet	8100-0000-21016	
INTERNAL REVENUE SERVICE	1/9/2026	2600377	1/9/2026	62010507	FEDERAL W/H	108,331.60	Liability Clearing Acct.	Balance Sheet	8100-0000-21005	
INTERNAL REVENUE SERVICE	1/9/2026	2600377	1/9/2026	62010507	FICA W/H TAX	86,100.36	Liability Clearing Acct.	Balance Sheet	8100-0000-21008	
INTERNAL REVENUE SERVICE	1/9/2026	2600377	1/9/2026	62010507	MEDICARE W/H TAX	32,110.74	Liability Clearing Acct.	Balance Sheet	8100-0000-21009	
UNITED WAY QUAD CITIES	1/9/2026	2600378	1/9/2026	PR 01.09.26 UNITED WAY	01/09/2026 PR CONTRIBUTIONS	847.73	Liability Clearing Acct.	Balance Sheet	8100-0000-21017	
NATIONWIDE RETIREMENT SOLUTIONS	1/9/2026	2600380	1/9/2026	PR 01.09.26 NATIONWIDE	457 CONTRIBUTIONS	765.70	Liability Clearing Acct.	Balance Sheet	8100-0000-21020	
MUNICIPAL FIRE & POLICE	1/9/2026	2600381	1/9/2026	01/09/2026 MFPRSI	EMPLOYEE SHARE POLICE PENSION	18,832.26	Liability Clearing Acct.	Balance Sheet	8100-0000-21011	
MUNICIPAL FIRE & POLICE	1/9/2026	2600381	1/9/2026	01/09/2026 MFPRSI	CITY SHARE POLICE PENSION	43,903.00	Liability Clearing Acct.	Balance Sheet	8100-0000-21003	
MUNICIPAL FIRE & POLICE	1/9/2026	2600381	1/9/2026	01/09/2026 MFPRSI	EMP SHARE FIRE PENSION	14,956.16	Liability Clearing Acct.	Balance Sheet	8100-0000-21012	
MUNICIPAL FIRE & POLICE	1/9/2026	2600381	1/9/2026	01/09/2026 MFPRSI	CITY SHARE FIRE PENSION	34,866.70	Liability Clearing Acct.	Balance Sheet	8100-0000-21004	
BETTENDORF POLICE BEVOLENT FUND	1/9/2026	2600382	1/9/2026	PR 01.09.26 BENVLT FUND	01/09/26 PR CONTRIBUTIONS	86.00	Liability Clearing Acct.	Balance Sheet	8100-0000-21029	
AMERICAN FUNDS ROTH IRA WIRE	1/9/2026	2600379	1/9/2026	2966-6540-04119	AFTER TAX ROTH IRA CONTRIBUTIONS	25.00	Liability Clearing Acct.	Balance Sheet	8100-0000-21014	
AFLAC	1/9/2026	2600383	1/9/2026	PR 01.09.26 CI WRAP	CI WRAP CONTRIBUTION	88.86	Liability Clearing Acct.	Balance Sheet	8100-0000-21014	
IOWA C.O.P.S.	1/9/2026	2600374	1/9/2026	PR 01.09.26 IA COPs	01/09/26 PR CONTRIBUTIONS	35.00	Liability Clearing Acct.	Balance Sheet	8100-0000-21029	
ILLINOIS DEPARTMENT OF REVENUE	1/9/2026	2600376	1/9/2026	1-902-531-440	ILLINOIS STATE W/H TAX	4,230.82	Liability Clearing Acct.	Balance Sheet	8100-0000-21007	
ICMA RETIREMENT TRUST - 457	1/9/2026	2600375	1/9/2026	6813108	457 LOAN PAYMENTS	4,688.60	Liability Clearing Acct.	Balance Sheet	8100-0000-21023	
ICMA RETIREMENT TRUST - 457	1/9/2026	2600375	1/9/2026	6813108	457 CONTRIBUTION PAYMENTS	69,691.64	Liability Clearing Acct.	Balance Sheet	8100-0000-21020	
ICMA RETIREMENT TRUST - 457	1/9/2026	2600375	1/9/2026	6813108	457 B ROTH	4,146.57	Liability Clearing Acct.	Balance Sheet	8100-0000-21014	

Bettendorf City Council AP Disbursements - 03.03.26

Vendor Name	Check Date	Check #	Invoice Date	Invoice #	Memo	Amount	Fund	Dept	Account #	Project
ICMA RETIREMENT TRUST - 457	1/9/2026	2600375	1/9/2026	6813108	ICMA ROTH AFTER TAX	6,693.31	Liability Clearing Acct.	Balance Sheet	8100-0000-21014	
ICMA RETIREMENT TRUST - 457	1/23/2026	2600391	1/23/2026	7703977	457 LOAN PAYMENTS	4,732.57	Liability Clearing Acct.	Balance Sheet	8100-0000-21023	
ICMA RETIREMENT TRUST - 457	1/23/2026	2600391	1/23/2026	7703977	457 CONTRIBUTION PAYMENTS	63,308.99	Liability Clearing Acct.	Balance Sheet	8100-0000-21020	
ICMA RETIREMENT TRUST - 457	1/23/2026	2600391	1/23/2026	7703977	457 B ROTH	3,895.38	Liability Clearing Acct.	Balance Sheet	8100-0000-21014	
ICMA RETIREMENT TRUST - 457	1/23/2026	2600391	1/23/2026	7703977	ICMA ROTH AFTER TAX	6,499.45	Liability Clearing Acct.	Balance Sheet	8100-0000-21014	
AFLAC	1/23/2026	2600392	1/23/2026	613575	AFLAC PRE TAX	2,310.48	Liability Clearing Acct.	Balance Sheet	8100-0000-21020	
AFLAC	1/23/2026	2600392	1/23/2026	613575	AFLAC AFTER TAX CONTRIBUTIONS	1,430.44	Liability Clearing Acct.	Balance Sheet	8100-0000-21014	
GREAT AMERICAN PLAN ADMINISTRATORS	1/23/2026	2600393	1/23/2026	PR 01.23.26 GREAT AMERICAN	01/23/2026 PR CONTRIBUTIONS	529.27	Liability Clearing Acct.	Balance Sheet	8100-0000-21020	
AMERICAN FUNDS ROTH IRA WIRE	1/23/2026	2600394	1/23/2026	1929-6343-20413	AFTER TAX ROTH IRA CONTRIBUTIONS	25.00	Liability Clearing Acct.	Balance Sheet	8100-0000-21014	
NATIONWIDE RETIREMENT SOLUTIONS	1/23/2026	2600396	1/23/2026	PR 01.23.26 NATIONWIDE	457 CONTRIBUTIONS	765.70	Liability Clearing Acct.	Balance Sheet	8100-0000-21020	
IOWA DEPARTMENT OF REVENUE	1/23/2026	2600398	1/23/2026	0-009-857-098	01/23/2026 PAY DATE IA W/H TAX	22,360.97	Liability Clearing Acct.	Balance Sheet	8100-0000-21006	
MUNICIPAL FIRE & POLICE	1/23/2026	2600397	1/23/2026	01/23/2026 MFPRSI	EMPLOYEE SHARE POLICE PENSION	17,584.64	Liability Clearing Acct.	Balance Sheet	8100-0000-21011	
MUNICIPAL FIRE & POLICE	1/23/2026	2600397	1/23/2026	01/23/2026 MFPRSI	CITY SHARE POLICE PENSION	40,994.45	Liability Clearing Acct.	Balance Sheet	8100-0000-21003	
MUNICIPAL FIRE & POLICE	1/23/2026	2600397	1/23/2026	01/23/2026 MFPRSI	EMP SHARE FIRE PENSION	13,261.44	Liability Clearing Acct.	Balance Sheet	8100-0000-21012	
MUNICIPAL FIRE & POLICE	1/23/2026	2600397	1/23/2026	01/23/2026 MFPRSI	CITY SHARE FIRE PENSION	30,915.99	Liability Clearing Acct.	Balance Sheet	8100-0000-21004	
IPERS COLLECTIONS	1/23/2026	2600399	1/23/2026	121228117	EMPLOYEE SHARE IPERS	40,761.46	Liability Clearing Acct.	Balance Sheet	8100-0000-21010	
IPERS COLLECTIONS	1/23/2026	2600399	1/23/2026	121228117	CITY SHARE IPERS	61,174.52	Liability Clearing Acct.	Balance Sheet	8100-0000-21010	
UNITED WAY QUAD CITIES	1/23/2026	2600395	1/23/2026	PR 01.23.26 UNITED WAY	01/23/2026 PR CONTRIBUTIONS	847.73	Liability Clearing Acct.	Balance Sheet	8100-0000-21017	
AFLAC	1/23/2026	2600400	1/23/2026	PR 01.23.26 CI WRAP	CI WRAP CONTRIBUTION	88.96	Liability Clearing Acct.	Balance Sheet	8100-0000-21014	
IOWA C.O.P.S.	1/23/2026	2600386	1/23/2026	PR 01.23.26 IA COPs	01/23/2026 PR CONTRIBUTIONS	35.00	Liability Clearing Acct.	Balance Sheet	8100-0000-21029	
COLLECTION SERVICES CENTER	1/23/2026	2600387	1/23/2026	2706771	CHILD/SPOUSE SUPPORT	1,498.26	Liability Clearing Acct.	Balance Sheet	8100-0000-21016	
ILLINOIS DEPARTMENT OF REVENUE	1/23/2026	2600390	1/23/2026	2-062-092-144	ILLINOIS STATE W/H TAX	3,974.02	Liability Clearing Acct.	Balance Sheet	8100-0000-21007	
INTERNAL REVENUE SERVICE	1/23/2026	2600388	1/23/2026	91460124	FEDERAL W/H	87,353.62	Liability Clearing Acct.	Balance Sheet	8100-0000-21005	
INTERNAL REVENUE SERVICE	1/23/2026	2600388	1/23/2026	91460124	FICA W/H TAX	81,334.76	Liability Clearing Acct.	Balance Sheet	8100-0000-21008	
INTERNAL REVENUE SERVICE	1/23/2026	2600388	1/23/2026	91460124	MEDICARE W/H TAX	29,230.78	Liability Clearing Acct.	Balance Sheet	8100-0000-21009	
BETTENDORF POLICE BENEVOLENT FUND	1/23/2026	2600389	1/23/2026	PR 01.23.26 BENVLT FUND	01/23/2026 PR CONTRIBUTIONS	86.00	Liability Clearing Acct.	Balance Sheet	8100-0000-21029	
AMERICAN FUNDS ROTH IRA WIRE	2/6/2026	2600412	2/6/2026	8004-6530-22615	AFTER TAX ROTH IRA CONTRIBUTIONS	25.00	Liability Clearing Acct.	Balance Sheet	8100-0000-21014	
IOWA DEPARTMENT OF REVENUE	2/6/2026	2600413	2/6/2026	0-009-902-038	02/06/2026 PAY DATE IA W/H TAX	23,613.38	Liability Clearing Acct.	Balance Sheet	8100-0000-21006	
AFLAC	2/6/2026	2600401	2/6/2026	PR 02.06.26 CI WRAP	CI WRAP CONTRIBUTION	88.96	Liability Clearing Acct.	Balance Sheet	8100-0000-21014	
IPERS COLLECTIONS	2/6/2026	2600404	2/6/2026	121231729	EMPLOYEE SHARE IPERS	41,164.90	Liability Clearing Acct.	Balance Sheet	8100-0000-21010	
IPERS COLLECTIONS	2/6/2026	2600404	2/6/2026	121231729	CITY SHARE IPERS	61,780.15	Liability Clearing Acct.	Balance Sheet	8100-0000-21010	
COLLECTION SERVICES CENTER	2/6/2026	2600410	2/6/2026	2711404	CHILD/SPOUSE SUPPORT	1,681.24	Liability Clearing Acct.	Balance Sheet	8100-0000-21016	
BETTENDORF POLICE BENEVOLENT FUND	2/6/2026	2600411	2/6/2026	PR 02.06.26 BENVLT FUND	02/06/2026 PR CONTRIBUTIONS	86.00	Liability Clearing Acct.	Balance Sheet	8100-0000-21029	
INTERNAL REVENUE SERVICE	2/6/2026	2600406	2/6/2026	61194624	FEDERAL W/H	92,520.26	Liability Clearing Acct.	Balance Sheet	8100-0000-21005	
INTERNAL REVENUE SERVICE	2/6/2026	2600406	2/6/2026	61194624	FICA W/H TAX	82,395.72	Liability Clearing Acct.	Balance Sheet	8100-0000-21008	
INTERNAL REVENUE SERVICE	2/6/2026	2600406	2/6/2026	61194624	MEDICARE W/H TAX	30,348.94	Liability Clearing Acct.	Balance Sheet	8100-0000-21009	
ILLINOIS DEPARTMENT OF REVENUE	2/6/2026	2600407	2/6/2026	1-504-786-288	ILLINOIS STATE W/H TAX	4,175.21	Liability Clearing Acct.	Balance Sheet	8100-0000-21007	
ICMA RETIREMENT TRUST - 457	2/6/2026	2600408	2/6/2026	6360123	457 LOAN PAYMENTS	4,938.38	Liability Clearing Acct.	Balance Sheet	8100-0000-21023	
ICMA RETIREMENT TRUST - 457	2/6/2026	2600408	2/6/2026	6360123	457 CONTRIBUTION PAYMENTS	64,085.69	Liability Clearing Acct.	Balance Sheet	8100-0000-21020	
ICMA RETIREMENT TRUST - 457	2/6/2026	2600408	2/6/2026	6360123	457 B ROTH	3,993.25	Liability Clearing Acct.	Balance Sheet	8100-0000-21014	
ICMA RETIREMENT TRUST - 457	2/6/2026	2600408	2/6/2026	6360123	ICMA ROTH AFTER TAX	6,562.82	Liability Clearing Acct.	Balance Sheet	8100-0000-21014	
GREAT AMERICAN PLAN ADMINISTRATORS	2/6/2026	2600409	2/6/2026	PR 02.06.26 GREAT AMERICAN	02/06/2026 PR CONTRIBUTIONS	553.38	Liability Clearing Acct.	Balance Sheet	8100-0000-21020	
UNITED WAY QUAD CITIES	2/6/2026	2600402	2/6/2026	PR 02.06.26 UNITED WAY	02/06/2026 PR CONTRIBUTIONS	847.73	Liability Clearing Acct.	Balance Sheet	8100-0000-21017	
NATIONWIDE RETIREMENT SOLUTIONS	2/6/2026	2600414	2/6/2026	PR 02.06.26 NATIONWIDE	457 CONTRIBUTIONS	765.70	Liability Clearing Acct.	Balance Sheet	8100-0000-21020	
MUNICIPAL FIRE & POLICE	2/6/2026	2600403	2/6/2026	02/06/2026 MFPRSI	EMPLOYEE SHARE POLICE PENSION	17,610.35	Liability Clearing Acct.	Balance Sheet	8100-0000-21011	
MUNICIPAL FIRE & POLICE	2/6/2026	2600403	2/6/2026	02/06/2026 MFPRSI	CITY SHARE POLICE PENSION	41,054.43	Liability Clearing Acct.	Balance Sheet	8100-0000-21003	
MUNICIPAL FIRE & POLICE	2/6/2026	2600403	2/6/2026	02/06/2026 MFPRSI	EMP SHARE FIRE PENSION	14,057.82	Liability Clearing Acct.	Balance Sheet	8100-0000-21012	
MUNICIPAL FIRE & POLICE	2/6/2026	2600403	2/6/2026	02/06/2026 MFPRSI	CITY SHARE FIRE PENSION	32,772.50	Liability Clearing Acct.	Balance Sheet	8100-0000-21004	
IOWA C.O.P.S.	2/6/2026	2600405	2/6/2026	PR 02.06.26 IA COPs	02/06/2026 PR CONTRIBUTIONS	35.00	Liability Clearing Acct.	Balance Sheet	8100-0000-21029	
LINCOLN LIFE	2/20/2026	133094	2/20/2026	PR 02.20.26 LINCOLN	LINCOLN LIFE INSURANCE	956.16	Liability Clearing Acct.	Balance Sheet	8100-0000-21020	
FAMILY SUPPORT PAYMENT CENTER	2/20/2026	133092	2/20/2026	PR 02.20.26 MO CHILD SUPPORT	MISSOURI CHILD SUPPORT REM ID: 31326587	10.29	Liability Clearing Acct.	Balance Sheet	8100-0000-21016	
WASHINGTON NATIONAL LIFE INSURANCE	2/20/2026	133097	2/20/2026	PR 02.20.26 WASHINGTON	WASHINGTON MUTUAL LIFE INSURANCE EMPLOYEE DEDUCTIONS	61.10	Liability Clearing Acct.	Balance Sheet	8100-0000-21014	
PACIFIC LIFE INSURANCE COMPANY	2/20/2026	133095	2/20/2026	PR 02.20.26 PACIFIC	PACIFIC LIFE INSURANCE	323.25	Liability Clearing Acct.	Balance Sheet	8100-0000-21020	
STATE DISBURSEMENT UNIT	2/20/2026	133096	2/20/2026	PR 02.20.26 IL CHILD SUPPORT	IL CHILD SUPPORT DEDUCTIONS FROM EMPLOYEES	911.98	Liability Clearing Acct.	Balance Sheet	8100-0000-21016	
LEGALSHIELD	2/20/2026	133093	2/20/2026	PR 02.20.26 LEGALSHIELD	LEGALSHIELD	55.83	Liability Clearing Acct.	Balance Sheet	8100-0000-21014	
AMERICAN FUNDS ROTH IRA WIRE	2/20/2026	133089	2/20/2026	PR 02.20.26 AM FUNDS	AMERICAN FUNDS EMPLOYEE DEDUCTION	50.00	Liability Clearing Acct.	Balance Sheet	8100-0000-21014	
CITY OF BETTENDORF	2/20/2026	133091	2/20/2026	PR 02.20.26 COB	EMPLOYEE INSURANCE PREM DEDUCTIONS	21,431.39	Liability Clearing Acct.	Balance Sheet	8100-0000-21018	
CITY OF BETTENDORF	2/20/2026	133091	2/20/2026	PR 02.20.26 COB	ORTHO	97.50	Liability Clearing Acct.	Balance Sheet	8100-0000-21019	
CITY OF BETTENDORF	2/20/2026	133091	2/20/2026	PR 02.20.26 COB	FLEX SPENDING	5,022.47	Liability Clearing Acct.	Balance Sheet	8100-0000-21020	
CITY OF BETTENDORF	2/20/2026	133091	2/20/2026	PR 02.20.26 COB	DEPENDENT CARE	1,915.70	Liability Clearing Acct.	Balance Sheet	8100-0000-21020	
CITY OF BETTENDORF	2/20/2026	133091	2/20/2026	PR 02.20.26 COB	PREM PASS THRU	2,002.74	Liability Clearing Acct.	Balance Sheet	8100-0000-21020	
ANCHOR NATIONAL LIFE INSURANCE CO	2/20/2026	133090	2/20/2026	PR 02.20.26 AIG	ANCHOR LIFE INSURANCE	236.77	Liability Clearing Acct.	Balance Sheet	8100-0000-21020	
IOWA DEPARTMENT OF REVENUE	2/20/2026	2600434	2/20/2026	0-010-009-502	02/20/2026 PAY DATE IA W/H TAX	22,184.70	Liability Clearing Acct.	Balance Sheet	8100-0000-21006	
IPERS COLLECTIONS	2/20/2026	2600437	2/20/2026	121232994	EMPLOYEE SHARE IPERS	40,592.24	Liability Clearing Acct.	Balance Sheet	8100-0000-21010	

**Bettendorf City Council AP Disbursements - 03.03.26**

Vendor Name	Check Date	Check #	Invoice Date	Invoice #	Memo	Amount	Fund	Dept	Account #	Project
IPERS COLLECTIONS	2/20/2026	2600437	2/20/2026	121232994	CITY SHARE IPERS	60,920.46	Liability Clearing Acct.	Balance Sheet	8100-0000-21010	
INTERNAL REVENUE SERVICE	2/20/2026	2600438	2/20/2026	101042526	FEDERAL W/H	86,672.36	Liability Clearing Acct.	Balance Sheet	8100-0000-21005	
INTERNAL REVENUE SERVICE	2/20/2026	2600438	2/20/2026	101042526	FICA W/H TAX	81,446.08	Liability Clearing Acct.	Balance Sheet	8100-0000-21008	
INTERNAL REVENUE SERVICE	2/20/2026	2600438	2/20/2026	101042526	MEDICARE W/H TAX	28,991.64	Liability Clearing Acct.	Balance Sheet	8100-0000-21009	
ICMA RETIREMENT TRUST - 457	2/20/2026	2600435	2/20/2026	7067426	457 LOAN PAYMENTS	4,938.38	Liability Clearing Acct.	Balance Sheet	8100-0000-21023	
ICMA RETIREMENT TRUST - 457	2/20/2026	2600435	2/20/2026	7067426	457 CONTRIBUTION PAYMENTS	62,302.98	Liability Clearing Acct.	Balance Sheet	8100-0000-21020	
ICMA RETIREMENT TRUST - 457	2/20/2026	2600435	2/20/2026	7067426	457 B ROTH	3,965.40	Liability Clearing Acct.	Balance Sheet	8100-0000-21014	
ICMA RETIREMENT TRUST - 457	2/20/2026	2600435	2/20/2026	7067426	ICMA ROTH AFTER TAX	6,543.81	Liability Clearing Acct.	Balance Sheet	8100-0000-21014	
MUNICIPAL FIRE & POLICE	2/20/2026	2600436	2/20/2026	02/20/2026 MFPRSI	EMPLOYEE SHARE POLICE PENSION	17,148.60	Liability Clearing Acct.	Balance Sheet	8100-0000-21011	
MUNICIPAL FIRE & POLICE	2/20/2026	2600436	2/20/2026	02/20/2026 MFPRSI	CITY SHARE POLICE PENSION	39,977.86	Liability Clearing Acct.	Balance Sheet	8100-0000-21003	
MUNICIPAL FIRE & POLICE	2/20/2026	2600436	2/20/2026	02/20/2026 MFPRSI	EMP SHARE FIRE PENSION	13,047.97	Liability Clearing Acct.	Balance Sheet	8100-0000-21012	
MUNICIPAL FIRE & POLICE	2/20/2026	2600436	2/20/2026	02/20/2026 MFPRSI	CITY SHARE FIRE PENSION	30,418.31	Liability Clearing Acct.	Balance Sheet	8100-0000-21004	
						<b>2,133,351.50</b>	<b>Liability Clearing Acct. Total</b>			
						<b>4,273,466.80</b>	<b>Grand Total</b>			

**Bettendorf City QCWCC AP Disbursements - 03.03.26**

Vendor Name	Check Date	Check #	Invoice Date	Invoice #	Memo	Amount	Fund	Dept	Account #
TREASURER, STATE OF IOWA	2/23/2026	2600365	11/30/2025	113025QCWCC	qccc tax	16,171.82	QC WATERFRONT CONVENTION	Balance Sheet	5900-0000-20401
						16,171.82		<b>Balance Sheet Total</b>	
ELECTRICAL ENGINEERING & EQUIP. CO.	3/4/2026	3824	2/18/2026	1677-1001858	work on generator	<b>2,033.00</b>	QC WATERFRONT CONVENTION	2001 - QC Waterfront Conv Ctr	5900-2001-54006
ROCHESTER ARMORED CAR CO., INC.	3/4/2026	3825	1/31/2026	204238	Armored Car Transportation	129.96	QC WATERFRONT CONVENTION	2001 - QC Waterfront Conv Ctr	5900-2001-55081
						<b>2,162.96</b>		<b>2001 - QC Waterfront Conv Ctr Total</b>	
						<b>18,334.78</b>		<b>QC Waterfront Convention Center Total</b>	

## Bettendorf City Council P-card Disbursements - Feb26 Statement - 03.03.26

Transaction Date	Vendor Name	Amount	Memo	Fund	Department	Account	Project
1/15/2026	SPORTS FANS PIZZA	55.70	Meeting - Mayor Gallagher, Asst City Administrator JReiter, and City Atty CCurran 1/15/26	General Fund	Mayor & Council	1001-0101-53004	
1/16/2026	EB *ROCK ISLAND STATE	25.02	Registration for RI State of the City Address 1/29/26 - Mayor Gallagher & Asst City Admns JReiter	General Fund	Mayor & Council	1001-0101-53004	
1/21/2026	QUAD CITIES CHAMBER OF	20.00	Registration for 2026 IA Legislative Kickoff Forum (Finance Dir JSchadt)	General Fund	Mayor & Council	1001-0101-53004	
1/29/2026	EB *ROCK ISLAND STATE	12.51	Registration for RI State of the City Address 1/29/26 - Council Member SNaumann	General Fund	Mayor & Council	1001-0101-53004	
2/3/2026	QUAD CITIES CHAMBER OF	10,000.00	Registration - Quad Cities Chamber D.C. Advocacy Trip - Mayor Gallagher, Council Member CFlaherty, City Administrator DPloehn, Asst City Administrator JReiter, Finance Director JSchadt	General Fund	Mayor & Council	1001-0101-53004	
2/3/2026	SQ *HILTON GARDEN INN	14.00	BBN Meeting 2/3/26 - Council Member Baden	General Fund	Mayor & Council	1001-0101-53004	
2/3/2026	SQ *HILTON GARDEN INN	14.00	BBN Meeting 2/3/26 - Council Member JSechser	General Fund	Mayor & Council	1001-0101-53004	
2/3/2026	SQ *HILTON GARDEN INN	14.00	BBN Meeting 2/3/26 - Mayor Gallagher	General Fund	Mayor & Council	1001-0101-53004	
2/4/2026	EVERGREEN ART WORKS	324.00	300 copies of Council Goal Setting's Plan in Brief for SOTC Address; and 50 laminated copies for council and staff	General Fund	Mayor & Council	1001-0101-56006	
2/9/2026	HY-VEE BETTENDORF 1037	19.96	Food - City Council Budget Work Session 2/9/26	General Fund	Mayor & Council	1001-0101-53004	
2/10/2026	CASEYS #3954	45.21	Transportation - Gas - Chamber IA Capitol Trip Feb 10-11, 2026	General Fund	Mayor & Council	1001-0101-53004	
2/10/2026	CASEYS #3954	3.29	Food - Chamber IA Capitol Trip Feb 10-11, 2026	General Fund	Mayor & Council	1001-0101-53004	
2/10/2026	SQ *HY-VEE ANKENY #1 1022	9.10	Food - Chamber IA Capitol Trip Feb 10-11, 2026	General Fund	Mayor & Council	1001-0101-53004	
2/11/2026	JETHRO S N JAKE S SMOKEH	180.30	Food - Chamber IA Capitol Trip Feb 10-11, 2026	General Fund	Mayor & Council	1001-0101-53004	
2/11/2026	STAYBRIDGE SUITES	178.08	Lodging (CFlaherty) - Chamber IA Capitol Trip Feb 10-11, 2026	General Fund	Mayor & Council	1001-0101-53004	
2/11/2026	STAYBRIDGE SUITES	20.00	Parking - Chamber IA Capitol Trip Feb 10-11, 2026	General Fund	Mayor & Council	1001-0101-53004	
2/12/2026	ENTERPRISE RENT-A-CAR	283.37	Transportation - QC Chamber Capitol Trip Feb 10-11, 2026	General Fund	Mayor & Council	1001-0101-53004	
2/13/2026	TRAVEL GUARD GROUP INC	425.90	Travel Insurance - QC Chamber DC Fly In Apr 14-16, 2026	General Fund	Mayor & Council	1001-0101-53004	
2/13/2026	UNITED 0162374408079	1,263.73	Transportation Airfare City Admin DPloehn - QC Chamber DC Fly In Apr 14-16-2026	General Fund	Mayor & Council	1001-0101-53004	
2/13/2026	UNITED 0162374408080	1,263.73	Transportation Airfare Mayor Gallagher - QC Chamber DC Fly In Apr 14-16-2026	General Fund	Mayor & Council	1001-0101-53004	
2/13/2026	UNITED 0162374408081	1,263.73	2026	General Fund	Mayor & Council	1001-0101-53004	
2/13/2026	UNITED 0162374408082	1,263.73	Transportation Airfare Finance Dir JSchadt - QC Chamber DC Fly In Apr 14-16-2026	General Fund	Mayor & Council	1001-0101-53004	
2/13/2026	UNITED 0162374408083	1,263.73	Transportation Airfare Council Member CFlaherty - QC Chamber DC Fly In Apr 14-16-2026	General Fund	Mayor & Council	1001-0101-53004	
		<b>17,963.09</b>			<b>Mayor &amp; Council Total</b>		
1/16/2026	PAYROLLORG	312.00	2026 Payroll Association Dues	General Fund	Finance	1001-0202-53001	
1/21/2026	OFFICE EXPRESS	461.89	PAPER	General Fund	Finance	1001-0202-56006	
1/28/2026	QUADIANT LEASING USA O	477.27	Postage lease	General Fund	Finance	1001-0201-56008	
1/30/2026	GOVERNMENT FINANCE OFFICE	275.00	FY25 PAFR Award Submission	General Fund	Finance	1001-0202-55013	
2/8/2026	AUDITOR OF STATE	871.25	FY25 Audit Submission Fee	General Fund	Finance	1001-0202-55001	
2/8/2026	AUDITOR OF STATE	871.25	FY24 Audit Submission Fee	General Fund	Finance	1001-0202-55001	
2/10/2026	MAVERIK #5168	9.50	QC Chamber Capitol Trip.	General Fund	Finance	1001-0201-53004	
		<b>3,278.16</b>			<b>Finance Total</b>		
1/15/2026	B&H PHOTO 800-606-6969	(802.66)	Return on Drone - Shipped Late. Charge was on last p-card expense report. Credit back to same account. originally ordered for ERU.	General Fund	Police	1001-0318-56004	
1/15/2026	COLUMN PUBLIC NOTICE	26.50	Property Notice	General Fund	Police	1001-0311-55002	
1/15/2026	COLUMN PUBLIC NOTICE	51.11	Property Notice	General Fund	Police	1001-0311-55002	

## Bettendorf City Council P-card Disbursements - Feb26 Statement - 03.03.26

Transaction Date	Vendor Name	Amount	Memo	Fund	Department	Account	Project
1/15/2026	GALLS	129.44	Acaster Flashlight	General Fund	Police	1001-0311-56004	
1/16/2026	AMAZON MKTPL*GV58K0JX3	39.70	Cords for external hard drives	General Fund	Police	1001-0313-56004	
1/16/2026	AMAZON MKTPL*TH87K7X73	97.72	Flash Drives for Cell Phone Downloads	General Fund	Police	1001-0313-56004	
1/16/2026	CHICK-FIL-A #03572	10.48	Meal/Drone Pilot Exam in Dubuque, IA	General Fund	Police	1001-0310-53003	
1/16/2026	CULVERS OF ALTOONA	18.33	Meal/ILEA Dooley	General Fund	Police	1001-0310-53003	
1/16/2026	MEGA SAVER (5800 NORTHGL	25.61	Fuel/ILEA Dooley	General Fund	Police	1001-0310-53003	
1/16/2026	USPS PO 1808460374	18.88	Postage/Property Return Letter	General Fund	Police	1001-0315-56008	
1/19/2026	ARBYS 1472	15.72	Meal/Crash Investigation 2	General Fund	Police	1001-0310-53003	
1/19/2026	SCOTT COUNTY ANIMAL HOSPI	101.25	Vaccines/K9 Philly	General Fund	Police	1001-0311-56044	
1/20/2026	ENZOS CHICKEN	17.57	Meal/Crash Investigation 2	General Fund	Police	1001-0310-53003	
1/21/2026	AMAZON MKTPL*1ZINI7JL3	11.50	Ordered landing gear extensions for new Anafi Thermal Drone. Did not fit/work. Credit already on card.	General Fund	Police	1001-0311-56007	
1/21/2026	JIMMY JOHNS - 2038	14.21	Meal/Crash Investigation 2	General Fund	Police	1001-0310-53003	
1/21/2026	VISTAPRINT	31.98	Cards for range certifications	General Fund	Police	1001-0311-56007	
1/22/2026	HY-VEE SLVS MKT GRL 4600	17.17	With \$1 tip	General Fund	Police	1001-0310-53003	
1/23/2026	CULVERS	12.78	Meal/ILEA Dooley	General Fund	Police	1001-0310-53003	
1/23/2026	DES MOINES STAMP MFG CO	63.00	Notary Stamps for Bratek and Rawls	General Fund	Police	1001-0311-56007	
1/23/2026	IA SECRETARY OF STATE	30.00	Notary - Bratek	General Fund	Police	1001-0311-56007	
1/23/2026	IA SECRETARY OF STATE	30.00	Notary - Rawls	General Fund	Police	1001-0311-56007	
1/23/2026	JIMMY JOHNS - 2038	12.60	Meal/Crash Investigation 2	General Fund	Police	1001-0310-53003	
1/23/2026	KWIK STAR #1703	30.59	Fuel/ILEA Dooley	General Fund	Police	1001-0310-53003	
1/24/2026	TST*SUGAR FACTORY - ROSE	32.81	Meal/Intensive Trauma Recovery Retreat	General Fund	Police	1001-0310-53003	
1/24/2026	VILLAGEOF ROSEMONT - WILL	20.00	Parking/Intensive Trauma Recovery Retreat	General Fund	Police	1001-0310-53003	
1/25/2026	PATC TRAINING	150.00	Hostage Negotiations Recert/Ballard	General Fund	Police	1001-0310-53003	
1/26/2026	CULLIGAN OF QUAD CITIES O	101.90	Water/PD (1.14.26 and 1.20.26)	General Fund	Police	1001-0315-56007	
1/26/2026	DOCUPPOST.COM	14.45	26-439 Postage Receipt Letter To Vehicle Owner	General Fund	Police	1001-0315-56008	
1/26/2026	HY-VEE SILVIS 1600	15.06	Meal/Crash Investigation 2	General Fund	Police	1001-0310-53003	
1/26/2026	IA SECRETARY OF STATE	30.00	Notary - Blunk	General Fund	Police	1001-0311-56007	
1/26/2026	SQ *IOWA NARCOTICS OFFICE	25.00	2026 INOA Membership/Valdez	General Fund	Police	1001-0310-53003	
1/26/2026	SQ *IOWA NARCOTICS OFFICE	300.00	Registration/2026 INOA Conference	General Fund	Police	1001-0310-53003	
1/26/2026	TST*5 BOROUGH BAGELS	7.16	Meal/Iowa Sex Crimes Conference	General Fund	Police	1001-0310-53003	
1/26/2026	TST*WASABI WEST DES MOIN	33.38	Meal/Iowa Sex Crimes Conference	General Fund	Police	1001-0310-53003	
1/26/2026	WHOLEFDS WDM #10460	17.78	Meal/Iowa Sex Crimes Conference	General Fund	Police	1001-0310-53003	
1/27/2026	CULVERS SILVIS	15.60	Meal/Crash Investigation 2	General Fund	Police	1001-0310-53003	
1/27/2026	DAIGLE LAW GROUP	295.00	Tactical Operations Liability (Webinar)	General Fund	Police	1001-0310-53003	
1/27/2026	DES MOINES STAMP MFG CO	34.00	Notary Stamp - Blunk	General Fund	Police	1001-0311-56007	
1/27/2026	DOCUPPOST.COM	14.45	2026-486 Postage Receipt Letter To Owner	General Fund	Police	1001-0315-56008	
1/27/2026	DOUBLETREE BY HILTON CHIC	16.69	Power Drinks/Intensive Trauma Recovery Retreat	General Fund	Police	1001-0310-53003	
1/27/2026	HY-VEE BETTENDORF 1037	72.50	Bereavement arrangement	General Fund	Police	1001-0301-56004	
1/27/2026	PEAVEY CORP.	338.20	Evidence Processing Supplies	General Fund	Police	1001-0313-56007	
1/27/2026	TST*5 BOROUGH BAGELS	8.81	Meal/Iowa Sex Crimes Conference	General Fund	Police	1001-0310-53003	
1/27/2026	TST*WASABI - ANKENY	30.53	Meal/Iowa Sex Crimes Conference	General Fund	Police	1001-0310-53003	
1/28/2026	AMAZON MKTPLACE PMTS	(11.50)	\$11.50 Refund. Purchased Landing Gear Extensions for Anafi Drone. Did not work, returned and refunded.	General Fund	Police	1001-0311-56007	
1/28/2026	FH* GREY GROUP	795.00	Registration/UC Rescue Vehicle Tactics Training	General Fund	Police	1001-0310-53003	

## Bettendorf City Council P-card Disbursements - Feb26 Statement - 03.03.26

Transaction Date	Vendor Name	Amount	Memo	Fund	Department	Account	Project
1/28/2026	GALLS	156.60	Bratek Winter shirt	General Fund	Police	1001-0311-52009	
1/28/2026	MAVERIK #5017	20.08	Fuel/Iowa Sex Crimes Conference	General Fund	Police	1001-0310-53003	
1/28/2026	OFFICE EXPRESS	106.97	Office Supplies Minus \$16.97 (items not delivered yet)	General Fund	Police	1001-0315-56006	
1/28/2026	PANDA EXPRESS #2824	16.28	Meal/Crash Investigation 2	General Fund	Police	1001-0310-53003	
1/28/2026	SKILLPATH	528.94	Annual Pass for Courses	General Fund	Police	1001-0310-53003	
1/28/2026	TST*5 BOROUGH BAGELS	9.92	Meal/Iowa Sex Crimes Conference	General Fund	Police	1001-0310-53003	
1/29/2026	AMAZON.COM*PP7E188A3	51.36	Pants for Gish - ERU	General Fund	Police	1001-0318-56004	
1/29/2026	ENZOS CHICKEN	17.57	Meal/Crash Investigation 2	General Fund	Police	1001-0310-53003	
1/29/2026	SKILLPATH	(29.94)	Refunded Tax	General Fund	Police	1001-0310-53003	
1/29/2026	SQ *TROPHY WORLD	7.00	ERU Plaque/Connell	General Fund	Police	1001-0318-56004	
1/30/2026	CHICK-FIL-A #03631	11.21	Meal/Crash Investigation 2	General Fund	Police	1001-0310-53003	
1/30/2026	CULVERS	12.45	Meal/ILEA Dooley	General Fund	Police	1001-0310-53003	
1/30/2026	KWIK STAR #1703	30.02	Fuel/ILEA Dooley	General Fund	Police	1001-0310-53003	
1/30/2026	USPS PO 1808460374	18.88	Postage/Property Return Letter	General Fund	Police	1001-0315-56008	
2/2/2026	CK *MAMMOTH HOLDINGS M	440.00	SilverStar Car Wash. Police Department and Fire Department Vehicle Fleets. Monthly.	General Fund	Police	1001-0311-54004	
2/2/2026	UNIFORM DEN INC	6.00	Velcro	General Fund	Police	1001-0311-52009	
2/2/2026	UPS*BILLING CENTER	34.49	UPS Shipping. Ship Drone sold on Gov Deals to winning buyer.	General Fund	Police	1001-0315-56008	
2/3/2026	STERICYCLE, INC	681.79	Shredding	General Fund	Police	1001-0315-56007	
2/4/2026	AMAZON.COM*9A4H567S3	204.50	Flash Drives for Phone Downloads	General Fund	Police	1001-0313-56007	
2/4/2026	AUTOZONE #1908	6.49	Replacement micro 2 fuses for city vehicle 22405.	General Fund	Police	1001-0311-54004	
2/4/2026	CULLIGAN OF QUAD CITIES O	30.00	Dispenser Rental/PD	General Fund	Police	1001-0315-56007	
2/4/2026	CULLIGAN OF QUAD CITIES O	75.65	Water/PD	General Fund	Police	1001-0315-56007	
2/6/2026	AMAZON.COM*TV4UXIN3	34.83	Firearm cleaning supplies	General Fund	Police	1001-0311-56004	
2/6/2026	CASEYS #1941	24.17	Fuel/Travel To/From DCI Lab - Evidence	General Fund	Police	1001-0313-53004	
2/6/2026	CULVERS	7.48	Meal/ILEA Basic Academy - Dooley	General Fund	Police	1001-0310-53003	
2/6/2026	IOWA PRISON INDUSTRIES	152.00	Dooley - Uniforms for Academy	General Fund	Police	1001-0311-52009	
2/6/2026	KWIK STAR #1703	23.51	Fuel/ILEA Basic Academy - Dooley	General Fund	Police	1001-0310-53003	
2/6/2026	PAYPAL *IOWAASSOCIA	90.00	IaAWP Renewal Dues (\$10.00) IaAWP Conference Registration (\$80.00)	General Fund	Police	1001-0310-53003	
2/7/2026	IOWA POLICE CHIEFS ASSOCI	125.00	2026 Membership Renewal	General Fund	Police	1001-0301-53001	
2/7/2026	IOWA PRISON INDUSTRIES	(152.00)	REFUND - Dooley - Uniforms for Academy	General Fund	Police	1001-0311-52009	
2/9/2026	AMAZON.COM*3M5IS3R73	7.63	Thank you cards	General Fund	Police	1001-0315-56006	
2/9/2026	PAYPAL *IOWAASSOCIA	90.00	Registration/Iowa Association of Women Police Conference (Staes)	General Fund	Police	1001-0310-53003	
2/9/2026	USPS PO 1808460374	7.20	Postage	General Fund	Police	1001-0315-56008	
2/10/2026	CALIBRE PRESS	359.00	Registration/Finding the Leader in You (Staes)	General Fund	Police	1001-0310-53003	
2/10/2026	DOCUPOST.COM	14.45	26-1481 Postage Receipt Letter To Owner	General Fund	Police	1001-0315-56008	
2/10/2026	DOCUPOST.COM	14.45	26-1375 Postage Receipt Letter To Alisha Littig	General Fund	Police	1001-0315-56008	
2/10/2026	DOCUPOST.COM	14.45	26-1375 Postage Receipt Letter To RO	General Fund	Police	1001-0315-56008	
2/10/2026	DOCUPOST.COM	14.45	26-2314 Postage Receipt Letter To Owner	General Fund	Police	1001-0315-56008	
2/11/2026	AMAZON MKTPL*449PA2IH3	37.49	Grease Pens for Patrol	General Fund	Police	1001-0311-56004	
2/11/2026	CULLIGAN OF QUAD CITIES O	65.55	Water/PD	General Fund	Police	1001-0315-56007	
2/11/2026	K & K TRUE VALUE	37.99	Adjustable Painter Pole for Broom/Squad 201	General Fund	Police	1001-0311-56007	
2/12/2026	AMAZON MKTPL*G49J84RY3	9.99	Charging cord for squad 200's Streamlight flashlight	General Fund	Police	1001-0311-56004	
2/12/2026	AMAZON MKTPL*G49J84RY3	15.76	Door Keys for New ERU Members	General Fund	Police	1001-0318-56004	

## Bettendorf City Council P-card Disbursements - Feb26 Statement - 03.03.26

Transaction Date	Vendor Name	Amount	Memo	Fund	Department	Account	Project
2/12/2026	IPVM IP VIDEO MARKET I	199.00	Champion Membership to IPVM. Tech Advisory Platform/Information. Professional Memberships.	General Fund	Police	1001-0301-53001	
2/13/2026	CULVERS	12.78	Meal/ILEA Basic Academy - Dooley	General Fund	Police	1001-0310-53003	
2/13/2026	KWIK STAR #1703	19.50	Fuel/ILEA Basic Academy - Dooley	General Fund	Police	1001-0310-53003	
2/13/2026	THEISENSHOMEFARMAUTODAV	4.27	Bucket/K9 Training Prop	General Fund	Police	1001-0311-56044	
2/15/2026	AMAZON MKTPL*3L0FI4SQ3	1,086.40	MOBILE ROUTERS FOR SQUAD CARS FOR DEPARTMENT WIDE PATROL ASSIGNED LAPTOP ROLL OUT. TRANS 1 OF 2. TRAFFIC MINOR EQUIPMENT. ENTERED INTO DEPT SPREADSHEET	General Fund	Police	1001-0316-56004	
		<b>7,111.91</b>			<b>Police Total</b>		
1/14/2026	JETHRO S BBQ	22.89	Meal/Hazmat Tech Training	General Fund	Fire	1001-0414-53003	
1/14/2026	JETHRO S BBQ	29.48	Meal/Hazmat Tech Certification	General Fund	Fire	1001-0414-53003	
1/14/2026	KWIK STAR #1705	68.97	Propane/ST4	General Fund	Fire	1001-0415-56007	
1/14/2026	SAMSClub.COM	230.16	Station Supplies	General Fund	Fire	1001-0415-56007	
1/15/2026	AIRGAS - NORTH SURCHARGE	62.29	Cylinder Rental (Nov)/ST1, ST2, ST4	General Fund	Fire	1001-0413-56010	
1/15/2026	AIRGAS - NORTH SURCHARGE	80.90	Oxygen and Cylinder Rental (Dec)/ST1, ST2, ST4	General Fund	Fire	1001-0413-56010	
1/15/2026	AMERICAN WATER WORKS COMP	29.15	Hydrant/ST2	General Fund	Fire	1001-0415-54011	
1/15/2026	AMERICAN WATER WORKS COMP	63.65	Hydrant/ST4	General Fund	Fire	1001-0415-54011	
1/15/2026	DSM PARKING METERS	1.50	Parking/Hazmat Tech Certification	General Fund	Fire	1001-0414-53003	
1/15/2026	EXXON 7-ELEVEN 34712	41.88	Fuel/ILTF Training	General Fund	Fire	1001-0413-53003	
1/15/2026	FIREMANSHIP CONFERENCE	225.00	Registration/Firemanship Conference	General Fund	Fire	1001-0411-53003	
1/15/2026	HOLIDAY INN EXP & SUITES	110.88	Hotel/ILTF Training (Said and Lawson)	General Fund	Fire	1001-0413-53003	
1/15/2026	HOLIDAY INN EXP & SUITES	110.88	Hotel/ILTF Training (Peitscher and Martin)	General Fund	Fire	1001-0413-53003	
1/15/2026	SHELL OIL 57441944204	12.50	Fuel/ILTF Training	General Fund	Fire	1001-0413-53003	
1/15/2026	SQ *RAMMY'S SUB CONTRACTO	13.25	Meal/ILTF Training	General Fund	Fire	1001-0413-53003	
1/15/2026	SQ *RAMMY'S SUB CONTRACTO	20.08	Meal/ILTF Training	General Fund	Fire	1001-0413-53003	
1/15/2026	SQ *RAMMY'S SUB CONTRACTO	23.11	Meal/ILTF Training	General Fund	Fire	1001-0413-53003	
1/15/2026	SQ *RAMMY'S SUB CONTRACTO	24.81	Meal/ILTF Training	General Fund	Fire	1001-0413-53003	
1/15/2026	TST*IOWA TAPROOM	17.78	Meal/Hazmat Tech Training	General Fund	Fire	1001-0414-53003	
1/15/2026	TST*IOWA TAPROOM	31.75	Meal/Hazmat Tech Certification	General Fund	Fire	1001-0414-53003	
1/15/2026	WPSG, INC.	70.45	Equipment Markers	General Fund	Fire	1001-0411-54006	FD0003
1/16/2026	BOUND TREE MEDICAL LLC	13.12	Medical Supplies	General Fund	Fire	1001-0413-56010	
1/16/2026	CULLIGAN OF QUAD CITIES O	44.20	Water/ST4	General Fund	Fire	1001-0415-56007	
1/16/2026	DPH REGULATORY PROGRAMS	25.00	Iowa Paramedic Recert/Logan	General Fund	Fire	1001-0413-53003	
1/16/2026	HAMPTON INN DESMOINES	561.55	Hotel/Hazmat Tech Certification (Bock and Feldmann)	General Fund	Fire	1001-0414-53003	
1/16/2026	KWIK STAR #1705	27.00	Fuel/Hazmat Tech Certification	General Fund	Fire	1001-0414-53003	
1/16/2026	RAISING CANES 0691	18.00	Meal/Hazmat Tech Training	General Fund	Fire	1001-0414-53003	
1/16/2026	RAISING CANES 0691	17.59	Meal/Hazmat Tech Certification	General Fund	Fire	1001-0414-53003	
1/16/2026	THE HOME DEPOT #2111	134.16	Chains and Hooks/TC Props	General Fund	Fire	1001-0410-54001	
1/21/2026	EASTERN IOWA CC	24.00	BLS Recertification/Scott and McDonald (City of Bettendorf received reimbursement of \$12.00, check #1022)	General Fund	Fire	1001-0413-53003	
1/21/2026	FELD FIRE	3,006.00	Service Cascade System (Fill SCBA Tanks)/ST2	General Fund	Fire	1001-0411-54006	
1/21/2026	GREENWOOD CLEANING SYSTE	71.36	Station Supplies	General Fund	Fire	1001-0415-56007	
1/22/2026	AMAZON MKTPL*B17A12RG3	189.38	Waterproof 2-way Radios/Marine 1	General Fund	Fire	1001-0415-56004	
1/22/2026	BOUND TREE MEDICAL LLC	65.80	Medical Supplies	General Fund	Fire	1001-0413-56010	
1/22/2026	K & K TRUE VALUE	102.93	Station Supplies	General Fund	Fire	1001-0415-56007	

## Bettendorf City Council P-card Disbursements - Feb26 Statement - 03.03.26

Transaction Date	Vendor Name	Amount	Memo	Fund	Department	Account	Project
1/23/2026	AMAZON.COM*L20C35U53	72.16	Support Bracket/Marine 1	General Fund	Fire	1001-0415-54006	
1/24/2026	AMAZON MKTPL*YX6N1Y43	73.30	Waterproof Radio Cases/Rescue 4	General Fund	Fire	1001-0411-56004	
1/24/2026	K & K TRUE VALUE	34.99	Garbage Bags	General Fund	Fire	1001-0415-56007	
1/25/2026	AMAZON.COM*3UIW31L73	43.98	Remote Speaker Microphones/Marine 1	General Fund	Fire	1001-0415-56004	
1/26/2026	BOUND TREE MEDICAL LLC	869.04	Medical Supplies	General Fund	Fire	1001-0413-56010	
1/26/2026	CULLIGAN OF QUAD CITIES O	70.50	Water/ST1 (1.14.26 and 1.20.26)	General Fund	Fire	1001-0415-56007	
1/26/2026	CULLIGAN OF QUAD CITIES O	72.70	Water/ST2 (1.14.26 and 1.20.26)	General Fund	Fire	1001-0415-56007	
1/26/2026	DPH REGULATORY PROGRAMS	25.00	Iowa Paramedic Renewal	General Fund	Fire	1001-0413-53003	
1/26/2026	GREENWOOD CLEANING SYSTE	43.95	Station Supplies	General Fund	Fire	1001-0415-56007	
1/27/2026	WAL-MART #1241	50.09	Station Supplies	General Fund	Fire	1001-0401-56007	
1/29/2026	AMERICAN WATER WORKS COMP	195.18	Water Usage/ST2	General Fund	Fire	1001-0415-54011	
1/29/2026	AMERICAN WATER WORKS COMP	190.08	Water Usage/ST4	General Fund	Fire	1001-0415-54011	
1/29/2026	CULLIGAN OF QUAD CITIES O	44.20	Water/ST4	General Fund	Fire	1001-0415-56007	
1/29/2026	DINGES FIRE COMPANY INTER	250.00	Fire Gear Belt	General Fund	Fire	1001-0411-52009	
1/29/2026	IAAI	193.00	International Assoc of Arson Investigators (IAAI) 2026-2028 Membership/Akers	General Fund	Fire	1001-0412-53001	
1/30/2026	AMAZON MKTPL*PE04B4HE3	73.30	Waterproof Radio Cases/Engine 1 and Engine 2	General Fund	Fire	1001-0411-56004	
1/30/2026	GREENWOOD CLEANING SYSTE	161.61	Station Supplies	General Fund	Fire	1001-0415-56007	
1/30/2026	GREENWOOD CLEANING SYSTE	296.54	Station Supplies	General Fund	Fire	1001-0415-56007	
1/30/2026	NATIONAL REGISTRY EMT	25.00	National EMT Recert/Sheehan	General Fund	Fire	1001-0413-53003	
1/30/2026	SAMS CLUB.COM	327.30	Station Supplies	General Fund	Fire	1001-0415-56007	
1/31/2026	AMAZON MKTPL*H904S0VP3	36.65	Waterproof Radio Case/Engine 4	General Fund	Fire	1001-0411-56004	
1/31/2026	JIMMY JOHNS - 1269 - BM	10.80	Meal/101st Fire School	General Fund	Fire	1001-0411-53003	
1/31/2026	KWIK STAR #1701	5.13	Meal/101st Fire School	General Fund	Fire	1001-0411-53003	
1/31/2026	KWIK STAR #1701	35.33	Fuel/101st Fire School	General Fund	Fire	1001-0411-53003	
2/1/2026	AMAZON MKTPL*4B6E14J3	9.99	Blocks/EMS Training Prop	General Fund	Fire	1001-0413-56004	
2/1/2026	CASEYS #1938	5.97	Meal/101st Fire School	General Fund	Fire	1001-0411-53003	
2/1/2026	PANCHEROS MEXICAN GRILL	14.82	Meal/101st Fire School	General Fund	Fire	1001-0411-53003	
2/2/2026	DIVE RESCUE INTERNATIONAL	1,982.06	Mustang Ice Rescue Suits	General Fund	Fire	1001-0413-56004	
2/2/2026	EASTERN IOWA CC	200.00	ACLS Certification/Ciha (Paramedic Class Requirement)	General Fund	Fire	1001-0413-53003	
2/2/2026	IAAI	378.00	International Assoc of Arson Investigators (IAAI) and IL Chapter Renewal Memberships/Priest	General Fund	Fire	1001-0412-53001	
2/2/2026	IAAI	128.00	International Assoc of Arson Investigators (IAAI) FIT Renewal/Priest	General Fund	Fire	1001-0412-53001	
2/2/2026	NORTHWEST RIVER SUPPLIES	3,145.50	NSR ASR (All Surface Rescue) 155 Rescue Boat	General Fund	Fire	1001-0413-56004	
2/2/2026	RQIPARTNERS	75.00	NRP Certification/Ciha (Paramedic Class Requirement)	General Fund	Fire	1001-0413-53003	
2/2/2026	THE HOME DEPOT 2111	90.24	TruFuel	General Fund	Fire	1001-0411-54006	
2/3/2026	EASTERN IOWA CC	54.00	BLS Recertification/9 Firefighters	General Fund	Fire	1001-0413-53003	
2/3/2026	RESCUE SOURCE	282.65	SCBA Quick Fill Kits	General Fund	Fire	1001-0411-56004	
2/4/2026	AMAZON MKTPL*GN5YE4KN3	90.17	Seatbelt Cutter/Window Breakers	General Fund	Fire	1001-0413-56004	
2/4/2026	AMAZON MKTPL*GN5YE4KN3	8.99	Rubber Bands	General Fund	Fire	1001-0412-56006	
2/4/2026	CULLIGAN OF QUAD CITIES O	44.20	Water/ST2	General Fund	Fire	1001-0415-56007	
2/4/2026	CULLIGAN OF QUAD CITIES O	65.55	Water/ST1	General Fund	Fire	1001-0415-56007	
2/4/2026	K & K TRUE VALUE	31.01	Locks/Drug Boxes	General Fund	Fire	1001-0413-56010	
2/4/2026	THE HOME DEPOT #2111	9.85	Spring Links	General Fund	Fire	1001-0415-56007	
2/5/2026	BOUND TREE MEDICAL LLC	320.97	Medical Supplies	General Fund	Fire	1001-0413-56010	

## Bettendorf City Council P-card Disbursements - Feb26 Statement - 03.03.26

Transaction Date	Vendor Name	Amount	Memo	Fund	Department	Account	Project
2/5/2026	BOUND TREE MEDICAL LLC	45.58	Medical Supplies	General Fund	Fire	1001-0413-56010	
2/5/2026	UPS*1ZG776Y40338412879	14.51	UPS to ship a vehicle computer dock to SAE for outfitting	General Fund	Fire	1001-0415-56008	
2/5/2026	WPSG, INC.	656.61	Fire Structural Boots	General Fund	Fire	1001-0411-52009	
2/6/2026	FOL DA TANK 4	378.00	Hose Bed Straps	General Fund	Fire	1001-0411-54006	
2/6/2026	GENESIS HEALTH SYSTEM	113.67	Pharmacy	General Fund	Fire	1001-0413-56010	
2/6/2026	K & K TRUE VALUE	(19.99)	Return Drain Cleaner	General Fund	Fire	1001-0415-56007	
2/6/2026	K & K TRUE VALUE	116.50	Station Supplies	General Fund	Fire	1001-0415-56007	
2/6/2026	K & K TRUE VALUE	5.46	Hardware/EI Repair	General Fund	Fire	1001-0411-54006	
2/6/2026	THE HOME DEPOT #2111	16.98	Light Bulbs - Station 2	General Fund	Fire	1001-0415-54001	
2/6/2026	WCI*MWI	57.30	Waste Disposal/ST2	General Fund	Fire	1001-0415-56007	
2/6/2026	WCI*MWI	57.30	Waste Disposal/ST4	General Fund	Fire	1001-0415-56007	
2/7/2026	NATIONAL REGISTRY EMT	32.00	National Paramedic Recert/Peitscher	General Fund	Fire	1001-0413-53003	
2/7/2026	NATIONAL REGISTRY EMT	25.00	National EMT Recert/Kozlik	General Fund	Fire	1001-0413-53003	
2/8/2026	O'REILLY 701	177.87	Heater Hose/EI	General Fund	Fire	1001-0411-54004	
2/9/2026	AUTOZONE #1908	149.99	Trailer Battery	General Fund	Fire	1001-0415-54006	
2/9/2026	AUTOZONE #1908	(22.00)	Refund/Battery Core	General Fund	Fire	1001-0415-54006	
2/9/2026	MED*ROCK VALLEY PHYSICAL	15.00	Hazmat Physical Follow-up Test	General Fund	Fire	1001-0401-55013	
2/10/2026	DPH REGULATORY PROGRAMS	25.00	Iowa Paramedic Recert/Peitscher	General Fund	Fire	1001-0413-53003	
2/10/2026	DPH REGULATORY PROGRAMS	25.00	Iowa Paramedic Recert/Scheetz	General Fund	Fire	1001-0413-53003	
2/10/2026	GREENWOOD CLEANING SYSTE	87.90	Station Supplies	General Fund	Fire	1001-0415-56007	
2/10/2026	K & K TRUE VALUE	122.23	Station Supplies	General Fund	Fire	1001-0415-56007	
2/10/2026	MAVERIK #5168	9.87	Meal/Government Affairs: Iowa Capitol Trip	General Fund	Fire	1001-0401-53004	
2/10/2026	SAMSClub.COM	173.80	Station Supplies	General Fund	Fire	1001-0415-56007	
2/11/2026	CULLIGAN OF QUAD CITIES O	36.35	Water/ST2	General Fund	Fire	1001-0415-56007	
2/11/2026	CULLIGAN OF QUAD CITIES O	35.25	Water/ST1	General Fund	Fire	1001-0415-56007	
2/11/2026	CULLIGAN OF QUAD CITIES O	59.55	Water/ST4	General Fund	Fire	1001-0415-56007	
2/11/2026	USPS PO 1808460374	41.50	Postage	General Fund	Fire	1001-0415-56008	
2/12/2026	AMAZON MKTPL*UE44P83P3	137.74	Heavy Duty Tarp	General Fund	Fire	1001-0411-56004	
2/12/2026	BOUND TREE MEDICAL LLC	205.80	Medical Gloves/ST2 Invoice 66795256	General Fund	Fire	1001-0413-56010	
2/12/2026	BOUND TREE MEDICAL LLC	205.80	Medical Gloves/ST4 Invoice 66795254	General Fund	Fire	1001-0413-56010	
2/12/2026	THE HOME DEPOT #2111	9.97	Stake Flags	General Fund	Fire	1001-0415-56007	
2/13/2026	AMAZON MKTPL*8Y4625J93	587.71	Converter/Charger - E2	General Fund	Fire	1001-0411-54004	
2/13/2026	AMAZON MKTPL*O52BX6Q43	593.65	Return Request Made - Converter/Charger - E2	General Fund	Fire	1001-0411-54004	
2/13/2026	K & K TRUE VALUE	1.08	Hardware/Marine 1	General Fund	Fire	1001-0415-54006	
		<b>19,906.23</b>			<b>Fire Total</b>		
1/15/2026	AMAZON MKTPL*KP20J0793	41.78	Hands Free Phone Accessory	General Fund	Public Works	1001-0525-54001	2600MC
1/15/2026	K & K TRUE VALUE	34.76	Bungee Cord, 9V Batteries, Eye Bolts	General Fund	Public Works	1001-0525-54001	2600MC
1/16/2026	1000BULBS.COM	527.45	Light Fixtures, Ballasts	General Fund	Public Works	1001-0525-54001	2600LB
1/17/2026	VESTIS SERVICES LLC	33.20	Entry Rug Service	General Fund	Public Works	1001-0526-55081	2601LB
1/17/2026	VESTIS SERVICES LLC	55.70	Entry Rug Service	General Fund	Public Works	1001-0526-55081	2601MC
1/17/2026	VESTIS SERVICES LLC	49.38	entry rugs & first aid	General Fund	Public Works	1001-0572-55081	
1/22/2026	VESTIS SERVICES LLC	65.80	entry rug service	General Fund	Public Works	1001-0526-55081	2601CC
1/22/2026	VESTIS SERVICES LLC	54.78	entry rug service	General Fund	Public Works	1001-0526-55081	2601CH
1/23/2026	GREENWOOD CLEANING SYSTE	171.53	trash can liners	General Fund	Public Works	1001-0526-56007	2601MC
1/23/2026	TRANE SUPPLY-112603	230.96	RTU Igniters	General Fund	Public Works	1001-0525-54001	2600CH

## Bettendorf City Council P-card Disbursements - Feb26 Statement - 03.03.26

Transaction	Date	Vendor Name	Amount	Memo	Fund	Department	Account	Project
	1/24/2026	VESTIS SERVICES LLC	55.70	entry rug service	General Fund	Public Works	1001-0526-55081	2601MC
	1/24/2026	VESTIS SERVICES LLC	33.20	entry rug service	General Fund	Public Works	1001-0526-55081	2601LB
	1/24/2026	VESTIS SERVICES LLC	49.38	entry rugs & first aid	General Fund	Public Works	1001-0572-55081	
	1/27/2026	ADEL WHOLESALERS INC	250.20	plumbing supplies	General Fund	Public Works	1001-0572-56007	
	1/27/2026	AMAZON MKTPL*BO88R79U3	26.59	floor mop	General Fund	Public Works	1001-0526-56007	2601MC
	1/27/2026	AMAZON.COM*9L1I875E3	57.78	mop head refills	General Fund	Public Works	1001-0526-56007	2601MC
	1/27/2026	K & K TRUE VALUE	21.99	AA batteries	General Fund	Public Works	1001-0526-56007	2601CC
	1/27/2026	PLUMB SUPPLY - DAV - 018	208.41	plumbing supplies	General Fund	Public Works	1001-0572-56007	
	1/27/2026	SUNDBERG AMERICA	110.49	ice maker - lounge	General Fund	Public Works	1001-0525-54001	2600CH
	1/27/2026	THE HOME DEPOT #2111	102.90	plumbing supplies	General Fund	Public Works	1001-0572-56007	
	1/28/2026	K & K TRUE VALUE	13.26	drill bits, cover plates	General Fund	Public Works	1001-0525-54001	2600MC
	1/29/2026	AMERICAN WATER WORKS COMP	191.68	brine room water	General Fund	Public Works	1001-0525-54011	2600MC
	1/29/2026	AMERICAN WATER WORKS COMP	556.61	water service	General Fund	Public Works	1001-0525-54011	2600MC
	1/29/2026	AMERICAN WATER WORKS COMP	112.65	fire protection water service	General Fund	Public Works	1001-0525-54011	2600LB
	1/29/2026	AMERICAN WATER WORKS COMP	156.12	water service	General Fund	Public Works	1001-0525-54001	2600MC
	1/29/2026	AMERICAN WATER WORKS COMP	74.40	water service	General Fund	Public Works	1001-0525-54011	2600CC
	1/29/2026	AMERICAN WATER WORKS COMP	245.45	water service	General Fund	Public Works	1001-0525-54011	2600CH
	1/29/2026	AMERICAN WATER WORKS COMP	29.15	fire protection water service	General Fund	Public Works	1001-0525-54011	2600CH
	1/29/2026	AMERICAN WATER WORKS COMP	435.93	Archery Range	General Fund	Public Works	1001-0572-54011	
	1/29/2026	AMERICAN WATER WORKS COMP	18.95	Parks Maintenance	General Fund	Public Works	1001-0572-54011	
	1/29/2026	AMERICAN WATER WORKS COMP	43.88	Parks Maintenance	General Fund	Public Works	1001-0572-54011	
	1/30/2026	K & K TRUE VALUE	4.29	drill bits	General Fund	Public Works	1001-0525-54001	2600MC
	1/30/2026	K & K TRUE VALUE	66.98	sink repair	General Fund	Public Works	1001-0525-54001	2600CH
	2/2/2026	AMERICAN WATER WORKS COMP	23.75	warming house	General Fund	Public Works	1001-0572-54011	
	2/2/2026	GREAT WESTERN SUPPLY CO	564.77	cups, tp, towels, urinal mats	General Fund	Public Works	1001-0526-56007	2601CH
	2/2/2026	GREAT WESTERN SUPPLY CO	219.00	towels, Kleenex	General Fund	Public Works	1001-0526-56007	2601MC
	2/2/2026	K & K TRUE VALUE	17.99	fuel additive	General Fund	Public Works	1001-0572-56023	
	2/2/2026	PARK WAREHOUSE- LLC	2,781.23	park bench	General Fund	Public Works	1001-0572-56004	
	2/2/2026	SHERWIN-WILLIAMS703241	138.70	safety yellow paint	General Fund	Public Works	1001-0525-54001	2600MC
	2/4/2026	ADEL WHOLESALERS INC	108.43	Drinking fountain flow regulator	General Fund	Public Works	1001-0525-54001	
	2/4/2026	K & K TRUE VALUE	14.99	Fuses	General Fund	Public Works	1001-0525-54001	2600MC
	2/4/2026	VESTIS SERVICES LLC	65.80	Entry Rug service	General Fund	Public Works	1001-0526-55081	2601CC
	2/4/2026	VESTIS SERVICES LLC	54.78	Entry Rug Service	General Fund	Public Works	1001-0526-55081	2601CH
	2/4/2026	VESTIS SERVICES LLC	55.70	Entry Rug Service	General Fund	Public Works	1001-0526-55081	2601MC
	2/4/2026	VESTIS SERVICES LLC	33.20	Entry Rug Service	General Fund	Public Works	1001-0526-55081	2601LB
	2/4/2026	VESTIS SERVICES LLC	54.78	Entry Rug Service	General Fund	Public Works	1001-0526-55081	2601CH
	2/4/2026	VESTIS SERVICES LLC	65.80	Entry Rug Service	General Fund	Public Works	1001-0526-55081	2601CC
	2/4/2026	VESTIS SERVICES LLC	197.52	Rugs	General Fund	Public Works	1001-0572-55081	
	2/5/2026	AMERICAN WATER WORKS COMP	399.93	Water Service	General Fund	Public Works	1001-0525-54011	2600LB
	2/5/2026	K & K TRUE VALUE	25.97	Drinking fountain repair parts	General Fund	Public Works	1001-0525-54001	2600CC
	2/6/2026	AMAZON MKTPL*PR8739EC3	149.75	Battery Charger	General Fund	Public Works	1001-0525-54001	2600CC
	2/6/2026	GREENWOOD CLEANING SYSTE	87.60	TP, Disinfectant	General Fund	Public Works	1001-0526-56007	2601MC
	2/6/2026	K & K TRUE VALUE	31.56	Shop Supplies	General Fund	Public Works	1001-0572-56023	
	2/6/2026	THE HOME DEPOT #2111	12.98	Trim Screws	General Fund	Public Works	1001-0525-54001	2600MC
	2/6/2026	VESTIS SERVICES LLC	33.20	Entry Rug Service	General Fund	Public Works	1001-0526-55081	2601LB

## Bettendorf City Council P-card Disbursements - Feb26 Statement - 03.03.26

Transaction	Date	Vendor Name	Amount	Memo	Fund	Department	Account	Project
	2/6/2026	VESTIS SERVICES LLC	55.70	Entry Rug Service	General Fund	Public Works	1001-0526-55081	2601MC
	2/6/2026	VESTIS SERVICES LLC	49.38	rugs	General Fund	Public Works	1001-0572-55081	
	2/6/2026	WCI*MILLENNIUM WASTE	107.00	Dumpster Service	General Fund	Public Works	1001-0525-55081	2600IR
	2/9/2026	WCI*MILLENNIUM WASTE	100.00	Dumpster Service	General Fund	Public Works	1001-0525-55081	2600CC
	2/9/2026	WCI*MILLENNIUM WASTE	63.65	Dumpster Service	General Fund	Public Works	1001-0525-55081	2600LB
	2/9/2026	WCI*MILLENNIUM WASTE	90.21	Dumpster Service	General Fund	Public Works	1001-0525-55081	2600CH
	2/10/2026	AMERICAN WATER WORKS COMP	29.15	Fire Protection Water Service	General Fund	Public Works	1001-0525-54011	2600CH
	2/10/2026	AMERICAN WATER WORKS COMP	112.65	Fire Protection Water Service	General Fund	Public Works	1001-0525-54011	2600CH
	2/10/2026	GREAT WESTERN SUPPLY CO	18.00	Vacuum Cleaner Bags	General Fund	Public Works	1001-0526-56007	2601IR
	2/10/2026	GREAT WESTERN SUPPLY CO	127.24	Soap and Towels	General Fund	Public Works	1001-0526-56007	2601MC
	2/10/2026	K & K TRUE VALUE	24.97	Paint Supplies	General Fund	Public Works	1001-0525-54001	2600MC
	2/10/2026	VESTIS SERVICES LLC	148.18	Entry Mats and Towels	General Fund	Public Works	1001-0526-55081	2601IR
	2/12/2026	AUTOZONE #1908	28.18	Exhaust Fluid	General Fund	Public Works	1001-0572-56023	
	2/12/2026	GREAT WESTERN SUPPLY CO	372.42	Liners, Utensils, Kleenex, TP, Sanitizer	General Fund	Public Works	1001-0526-56007	2601CH
	2/12/2026	THE HOME DEPOT #2111	42.55	Electrical Box	General Fund	Public Works	1001-0525-54001	2600LB
	2/12/2026	VESTIS SERVICES LLC	33.20	Rug Service	General Fund	Public Works	1001-0526-55081	2601LB
	2/13/2026	GREAT WESTERN SUPPLY CO	67.68	Hand Soap	General Fund	Public Works	1001-0526-56007	2601IR
	2/13/2026	GREAT WESTERN SUPPLY CO	219.05	Hand Soap	General Fund	Public Works	1001-0526-56007	2601IR
	2/13/2026	THE HOME DEPOT #2111	42.96	Outlets	General Fund	Public Works	1001-0525-54001	2600MC
	2/14/2026	VESTIS SERVICES LLC	33.20	Entry Rug Service	General Fund	Public Works	1001-0526-55081	2601LB
	2/14/2026	VESTIS SERVICES LLC	55.70	Entry Rug Service	General Fund	Public Works	1001-0526-55081	2601MC
	2/14/2026	VESTIS SERVICES LLC	49.38	Rugs	General Fund	Public Works	1001-0572-55081	
			<b>11,139.21</b>			<b>Public Works Total</b>		
	1/15/2026	AMAZON MKTPL*DMIYS4AY3	12.55	Juvenile	General Fund	Library	1001-0680-57085	
	1/15/2026	PUTNAM MUSEUM	200.00	Reference - Putnam passes	General Fund	Library	1001-0680-57083	
	1/15/2026	QUILL CORPORATION	12.40	Adaptive Hole Punch	General Fund	Library	1001-0614-56006	
	1/15/2026	VISTAPRINT	112.32	Business Cards - Miller, Kehoe, Jackson	General Fund	Library	1001-0612-56006	
	1/15/2026	VISTAPRINT	37.44	Business cards - Gibbs	General Fund	Library	1001-0610-56006	
	1/16/2026	AMAZON MKTPL*137FOU63	23.93	Juvenile	General Fund	Library	1001-0680-57085	
	1/16/2026	AMAZON MKTPL*H678S6EX3	41.99	Nonfiction	General Fund	Library	1001-0680-57080	
	1/16/2026	DEMCO INC	251.30	Book cart for youth area	General Fund	Library	1001-0610-56006	
	1/17/2026	AMAZON MKTPL*CP5Z09LQ3	32.42	Nonfiction	General Fund	Library	1001-0680-57080	
	1/17/2026	AMAZON MKTPL*OU0AD3883	39.97	Video Games	General Fund	Library	1001-0680-57076	
	1/17/2026	AMAZON MKTPL*OU0AD3883	39.97	Highlighted Section (Separate shipments/charges)	General Fund	Library	1001-0680-57076	
	1/17/2026	QUILL CORPORATION	24.64	Pouches - Vault Money	General Fund	Library	1001-0601-56006	
	1/17/2026	QUILL CORPORATION	33.14	Ergonomic hole punch (adaptive tool for staff member)	General Fund	Library	1001-0614-56006	
	1/18/2026	AMAZON RETA* 6X97R2WM3	22.78	Nonfiction	General Fund	Library	1001-0680-57080	
	1/19/2026	AMAZON RETA* F01XO4V73	139.59	Nonfiction	General Fund	Library	1001-0680-57080	
	1/19/2026	VSP*BLACKSTONE WHOLESAL	29.69	Audio	General Fund	Library	1001-0680-57086	
	1/20/2026	AMAZON RETA* AP7G38V83	16.50	Fiction	General Fund	Library	1001-0680-57081	
	1/20/2026	AMAZON RETA* AP7G38V83	16.50	Highlighted section	General Fund	Library	1001-0680-57081	
	1/20/2026	AMAZON RETA* C27009KR3	18.14	Fiction	General Fund	Library	1001-0680-57081	
	1/20/2026	AMAZON RETA* J74OB03H3	73.20	Nonfiction	General Fund	Library	1001-0680-57080	
	1/20/2026	AMAZON RETA* V39SZ3EB3	17.60	Nonfiction	General Fund	Library	1001-0680-57080	
	1/20/2026	AMAZON RETA* V39SZ3EB3	17.60	Highlighted section (separate shipments/charges)	General Fund	Library	1001-0680-57080	

## Bettendorf City Council P-card Disbursements - Feb26 Statement - 03.03.26

Transaction Date	Vendor Name	Amount	Memo	Fund	Department	Account	Project
1/20/2026	USPS PO 1808460374	7.81	ILL postage	General Fund	Library	1001-0610-56008	
1/21/2026	AMAZON MKTPL*YK58Z6SH3	14.99	business card holders	General Fund	Library	1001-0610-56006	
1/21/2026	AMAZON RETA* YIIPQIFK3	24.99	Nonfiction	General Fund	Library	1001-0680-57080	
1/22/2026	FIGGE ART MUSEUM	150.00	Reference - Museum Pass	General Fund	Library	1001-0680-57083	
1/24/2026	AMAZON RETA* A56XA04H3	52.71	Nonfiction	General Fund	Library	1001-0680-57080	
1/25/2026	AMAZON RETA* FE7TZITW3	16.50	Fiction Highlighted section	General Fund	Library	1001-0680-57081	
1/25/2026	AMAZON RETA* UU0BPI603	45.59	Juvenile	General Fund	Library	1001-0680-57085	
1/26/2026	AMAZON RETA* KP1Z65FR3	32.97	Nonfiction	General Fund	Library	1001-0680-57080	
1/27/2026	AMAZON RETA* 8B9M52UB3	116.89	Young Adult	General Fund	Library	1001-0680-57082	
1/27/2026	QUILL CORPORATION	27.19	Binders	General Fund	Library	1001-0601-56006	
1/29/2026	AMAZON MKTPL*CR8ZG8PM3	6.99	Tech Svc. Supplies - Library of Things	General Fund	Library	1001-0614-56006	
1/30/2026	AMAZON RETA* DBIL20VK3	56.35	Video	General Fund	Library	1001-0680-57076	
1/30/2026	LIBRARYWORKS/MODLIBAWD	100.00	Collection promotion webinar for group of 4	General Fund	Library	1001-0614-53003	
1/31/2026	AMAZON RETA* 9V00E54H3	51.50	Video	General Fund	Library	1001-0680-57076	
1/31/2026	ASSOCIATION OF BOOKMOB	40.00	Subscription to Association of Bookmobile and Outreach Services	General Fund	Library	1001-0601-53001	
2/1/2026	AMAZON RETA* KF4SNINY3	14.99	Fiction	General Fund	Library	1001-0680-57081	
2/1/2026	AMAZON RETA* SI79950Q3	16.35	Juvenile	General Fund	Library	1001-0680-57085	
2/2/2026	AMAZON RETA* 7D5WO95O3	16.50	Nonfiction	General Fund	Library	1001-0680-57080	
2/2/2026	AMAZON RETA* C820J36P3	17.04	Fiction	General Fund	Library	1001-0680-57081	
2/3/2026	AMAZON MKTPL*RE9D86J13	19.76	Juvenile	General Fund	Library	1001-0680-57085	
2/3/2026	AMAZON RETA* Q64T604E3	85.78	Young Adult	General Fund	Library	1001-0680-57082	
2/3/2026	AMAZON RETA* RB7MKIOI3	53.96	Fiction	General Fund	Library	1001-0680-57081	
2/4/2026	AMAZON RETA* 9I6R83QC3	34.99	Video Games	General Fund	Library	1001-0680-57076	
2/4/2026	COPYRIGHT OSP	6.00	US Copyright Office Designated Agent fee	General Fund	Library	1001-0680-57078	
2/6/2026	AMAZON MKTPL*NS4X72X93	9.28	Fiction	General Fund	Library	1001-0680-57081	
2/6/2026	AMAZON RETA* 3M65R5Z73	49.99	Video games	General Fund	Library	1001-0680-57076	
2/6/2026	AMAZON RETA* DBIL20VK3	(56.35)	Video Refund of attached receipt	General Fund	Library	1001-0680-57076	
2/6/2026	AMAZON RETA* I30IW2WH3	39.99	Video games	General Fund	Library	1001-0680-57076	
2/6/2026	AMAZON RETA* RB7MKIOI3	(22.99)	Fiction Refund of highlighted section	General Fund	Library	1001-0680-57081	
2/6/2026	GROWING LIBRARIES LLC	3,103.67	Annual subscription Growing Libraries	General Fund	Library	1001-0601-55023	
2/8/2026	AMAZON RETA* IK6CF2IQ3	51.70	Nonfiction Highlighted section	General Fund	Library	1001-0680-57080	
2/8/2026	AMAZON RETA* IS2JEIVN3	154.89	Video games	General Fund	Library	1001-0680-57076	
2/9/2026	AMAZON RETA* 349771BK3	15.95	Fiction highlighted section	General Fund	Library	1001-0680-57081	
2/9/2026	AMAZON RETA* C31UH92I3	33.00	Fiction	General Fund	Library	1001-0680-57081	
2/9/2026	AMAZON RETA* TY8XM4RU3	24.28	Nonfiction Highlighted section	General Fund	Library	1001-0680-57080	
2/9/2026	NYTIMES	166.00	NYT monthly subscription renewal	General Fund	Library	1001-0680-57077	
2/10/2026	AMAZON RETA* 702US36W3	7.19	Young Adult Highlighted section	General Fund	Library	1001-0680-57082	
2/11/2026	AMAZON MKTPL*T575W4TY3	24.87	Fiction	General Fund	Library	1001-0680-57081	

## Bettendorf City Council P-card Disbursements - Feb26 Statement - 03.03.26

Transaction Date	Vendor Name	Amount	Memo	Fund	Department	Account	Project
2/11/2026	AMAZON MKTPL*TR9JH88M3	38.58	These are art poster carrying bags because the StoryWalk pages are 18 x 24 and awkward to carry in the wind. This will prevent them from blowing away while swapping the pictures.	General Fund	Library	1001-0612-56007	
2/11/2026	AMAZON RETA* IE4SQ54A3	39.99	Video Games Highlighted section	General Fund	Library	1001-0680-57076	
2/12/2026	AMAZON RETA* N688L3PD3	39.99	Video Games Highlighted	General Fund	Library	1001-0680-57076	
2/14/2026	QUILL CORPORATION	39.75	Paper Towels	General Fund	Library	1001-0601-56006	
2/14/2026	QUILL CORPORATION	27.98	Packing Tape	General Fund	Library	1001-0610-56006	
2/15/2026	AMAZON RETA* KH4DT6J13	34.99	Video games	General Fund	Library	1001-0680-57076	
2/15/2026	AMAZON RETA* NC1Z15FD3	49.99	Video games	General Fund	Library	1001-0680-57076	
		<b>6,022.19</b>			<b>Library Total</b>		
1/14/2026	PFS/ROMA TPC	(3.00)	skittles candy exchange	General Fund	Parks	1001-0730-56026	
1/15/2026	CULLIGAN OF QUAD CITIES	24.65	water jugs	General Fund	Parks	1001-0705-56007	
1/15/2026	CULLIGAN OF QUAD CITIES	10.00	water dispenser	General Fund	Parks	1001-0705-56007	
1/16/2026	QUAD CITIES CHAMBER OF	15.00	registration for YP & Night for Chamber	General Fund	Parks	1001-0703-53004	
1/16/2026	QUAD CITIES CHAMBER OF	15.00	registration for YP @ Night for Chamber	General Fund	Parks	1001-0705-53004	
1/19/2026	AMAZON MKTPL*N64PA4QL3	636.36	soccer balls, mesh bags, 2 folding goals	General Fund	Parks	1001-0703-56004	REC026
1/23/2026	GOOGLE YOUTUBE TV	88.80	youtube tv for the lodge	General Fund	Parks	1001-0730-56007	
1/23/2026	SAMS CLUB #8238	110.88	chips for Winter Festival	General Fund	Parks	1001-0740-56007	FEST04
1/23/2026	SAMS CLUB #8238	3.98	water for meetings	General Fund	Parks	1001-0701-53004	
1/23/2026	THE FUN STATION QUAD	615.25	deposit for field trip for day camp but was charged tax	General Fund	Parks	1001-0703-55013	REC015
1/26/2026	AMAZON MKTPL*N38DN5QX3	139.98	folding tables	General Fund	Parks	1001-0705-56004	BCC002
1/27/2026	AMAZON MKTPL*8Q8780RD3	86.74	servng cups for Winterfest	General Fund	Parks	1001-0740-56007	FEST04
1/27/2026	BP#6468490QC MART GRANT	2.45	candy bars for smores for Frosty Run	General Fund	Parks	1001-0703-56007	REC061
1/28/2026	AMAZON MKTPL*KU7AV92E3	22.49	pickleball net	General Fund	Parks	1001-0705-56004	
1/28/2026	AMAZON MKTPL*KY32Q4IK3	51.29	hockey pucks	General Fund	Parks	1001-0740-56007	FEST04
1/28/2026	DOLLAR TREE	8.50	candy & decor for community fairs	General Fund	Parks	1001-0703-56034	
1/28/2026	HIGHTECH SIGNS	35.75	signage for Frosty Run	General Fund	Parks	1001-0703-56007	REC061
1/28/2026	K & K TRUE VALUE	36.17	nails and hammer for Winterfest	General Fund	Parks	1001-0740-56007	FEST04
1/28/2026	NRPA OPERATING	3,200.00	Director's School conference	General Fund	Parks	1001-0701-53004	
1/28/2026	UNITED 0162369283060	534.41	flight to director's school conferences	General Fund	Parks	1001-0701-53004	
1/29/2026	CROWN TROPHY BETTENDORF	53.50	metal plates for back of medals	General Fund	Parks	1001-0703-56007	REC061
1/29/2026	U-HAUL AT SPRUCE HILLS	13.50	propane for smores	General Fund	Parks	1001-0740-56007	FEST04
1/30/2026	AMAZON MKTPL*DM3455QN3	65.97	supplies for Winterfest-stamper	General Fund	Parks	1001-0740-56007	FEST04
1/30/2026	THE FUN STATION QUAD	(615.25)	credit for field trip because of tax charged	General Fund	Parks	1001-0703-55013	REC015
1/30/2026	THE FUN STATION QUAD	500.00	deposit for field trip for day camp	General Fund	Parks	1001-0703-55013	REC015
1/30/2026	THE FUN STATION QUAD	(642.00)	refund for playgrounds week 3, day 1	General Fund	Parks	1001-0703-55013	REC020A
1/30/2026	THE FUN STATION QUAD	(642.00)	refund for playgrounds week 3, day 2	General Fund	Parks	1001-0703-55013	REC020A
1/30/2026	THE FUN STATION QUAD	(642.00)	refund for playgrounds week 3, day 3	General Fund	Parks	1001-0703-55013	REC020A
1/30/2026	THE FUN STATION QUAD	600.00	25% deposit for playgrounds week 3, day 1	General Fund	Parks	1001-0703-55013	REC020A
1/30/2026	THE FUN STATION QUAD	750.00	25% deposit for playgrounds week 3, day 3	General Fund	Parks	1001-0703-55013	REC020A
1/30/2026	THE FUN STATION QUAD	600.00	25% deposit for playgrounds week 3, day 2	General Fund	Parks	1001-0703-55013	REC020A
1/31/2026	AMAZON MKTPLACE PMTS	(51.29)	refund for hockey pucks	General Fund	Parks	1001-0740-56007	FEST04
2/1/2026	HY-VEE BETTENDORF 1037	584.97	hot dogs and food for Winterfest	General Fund	Parks	1001-0740-56007	FEST04

## Bettendorf City Council P-card Disbursements - Feb26 Statement - 03.03.26

Transaction Date	Vendor Name	Amount	Memo	Fund	Department	Account	Project
2/2/2026	AMAZON MKTPL*6S9KM45D3	87.98	nacho cheese	General Fund	Parks	1001-0730-56026	
2/3/2026	WM SUPERCENTER #1241	26.64	notebooks & binder	General Fund	Parks	1001-0703-56006	
2/4/2026	SP SPARX HOCKEY	368.93	blade sharpening rings	General Fund	Parks	1001-0730-56004	
2/5/2026	AMAZON MKTPL*O19A75873	9.58	sweetheart dance prizes	General Fund	Parks	1001-0703-56007	REC027
2/5/2026	HY-VEE BETTENDORF 1037	18.77	beer	General Fund	Parks	1001-0730-56027	
2/6/2026	AMAZON MKTPL*WT7GU2MM3	9.99	Sweetheart Dance Prize	General Fund	Parks	1001-0703-56007	
2/8/2026	PFS/ROMA TPC	43.90	lids	General Fund	Parks	1001-0730-56007	
2/9/2026	AMAZON.COM*5Z9V80OW3	31.02	sheet protectors	General Fund	Parks	1001-0701-56006	
2/9/2026	IPRA* IA	825.00	conference for John, Meredith and Cale	General Fund	Parks	1001-0701-53004	
2/10/2026	AMAZON MKTPL*0S3AM0NL3	426.12	sweetheart dance prizes	General Fund	Parks	1001-0703-56007	REC027
2/10/2026	AMAZON MKTPL*HP7S05JR3	39.99	rack card holder	General Fund	Parks	1001-0730-56004	
2/10/2026	AMAZON MKTPL*LR5SP6AD3	87.98	nacho cheese for resale	General Fund	Parks	1001-0730-56026	
2/13/2026	PFS/ROMA TPC	114.21	candy bars for resale	General Fund	Parks	1001-0730-56026	
2/13/2026	PFS/ROMA TPC	28.95	coffee for resale	General Fund	Parks	1001-0730-56026	
		<b>8,329.16</b>			<b>Parks Total</b>		
1/16/2026	AMAZON MKTPL*9N7X341F3	13.22	WHITE MEMO PADS	General Fund	Community Development	1001-3006-56006	
1/16/2026	QUAD CITIES CHAMBER OF	30.00	registration for YP & Night for Chamber	General Fund	Community Development	1001-3002-53004	
1/19/2026	AMAZON MKTPL*IH0H857V3	19.79	PHONE CAR MOUNT - BURKE	General Fund	Community Development	1001-3006-56007	
1/24/2026	LEE NEWS SUBSCRIPTION	4.99	Quad-City Times digital subscription	General Fund	Community Development	1001-3002-53002	
1/27/2026	AMAZON MKTPL*8POEM7IX3	159.99	Space heater	General Fund	Community Development	1001-3001-56006	
1/27/2026	SAMSClub.COM	85.06	Coffee cups, cocoa	General Fund	Community Development	1001-3001-56006	
1/28/2026	AMAZON RETA* O104Z18N3	119.95	Coffee maker	General Fund	Community Development	1001-3001-56006	
1/29/2026	AMAZON MKTPL*VC8OC6523	28.49	Cardboard map tubes	General Fund	Community Development	1001-3001-56006	
1/29/2026	INT'L CODE COUNCIL INC	255.00	plans reviewer certification test	General Fund	Community Development	1001-3006-53002	
2/4/2026	AMAZON MKTPL*M34VG0ST3	33.24	Cardboard map storage tubes	General Fund	Community Development	1001-3001-56006	
2/4/2026	AMAZON MKTPL*UX2QX9CD3	12.49	Coffee filters	General Fund	Community Development	1001-3001-56006	
2/10/2026	SQ *HY-VEE ANKENY #1 1022	13.91	Lunch at Iowa Capitol Visit with QC Chamber	General Fund	Community Development	1001-3002-53004	
2/11/2026	ISU EVENT REGISTRATION	100.00	Training workshop for data insights and public engagement. Registration is for Taylor Beswick and Alyssa Magsombol. Workshop is virtual, 2 hours, taking place on 2/26/26.	General Fund	Community Development	1001-3002-53003	
		<b>876.13</b>			<b>Community Development Total</b>		
1/15/2026	AMAZON MKTPL*159P45TS3	25.73	Earbud Dongles	General Fund	Economic Development	1001-3501-56006	
1/15/2026	EB *ROCK ISLAND STATE	12.51	Rock Island State of the City Address	General Fund	Economic Development	1001-3501-53004	
1/23/2026	CORAZON LATINO RESTAURANT	24.08	They were not able to figure out how to print out a receipt for me, so I took a screenshot of the menu and what I ordered - La Bombo Flatbread for \$15 plus tax + tip.	General Fund	Economic Development	1001-3501-53004	
2/3/2026	EPIDEMIC SOUND AB	19.25	Monthly subscription for music in videos	General Fund	Economic Development	1001-3503-56019	
2/3/2026	LS THE CAMERA CORNER,	60.00	Camera Corner University	General Fund	Economic Development	1001-3501-55033	
2/3/2026	SQ *HILTON GARDEN INN	28.00	BBN lunch for Denice and myself	General Fund	Economic Development	1001-3501-53004	
2/4/2026	OFFICE EXPRESS	12.97	Dry Erase Markers	General Fund	Economic Development	1001-3501-56006	
2/6/2026	BRUEGGERS_MOBILE	5.00	Bruegger's App Reload for SOTC Work	General Fund	Economic Development	1001-3501-53004	
2/8/2026	LEE NEWS SUBSCRIPTION	40.99	QC Times Monthly Subscription	General Fund	Economic Development	1001-3501-55033	
2/9/2026	DUNKIN' MOBILE	58.00	Breakfast for ILC Conference Helpers Committee Meeting	General Fund	Economic Development	1001-3501-53004	
2/10/2026	MAVERIK #5168	8.32	QC Chamber Advocacy Trip to Des Moines	General Fund	Economic Development	1001-3501-53004	
2/11/2026	STAYBRIDGE SUITES	20.00	QC Chamber Des Moines Advocacy Trip	General Fund	Economic Development	1001-3501-53004	

## Bettendorf City Council P-card Disbursements - Feb26 Statement - 03.03.26

Transaction Date	Vendor Name	Amount	Memo	Fund	Department	Account	Project
2/12/2026	ENTERPRISE RENT-A-CAR	301.06	QC Chamber Des Moines Advocacy Trip	General Fund	Economic Development	1001-3501-53004	
		<b>615.91</b>			<b>Economic Development Total</b>		
1/26/2026	THOMSON WEST*TCD	376.50	Invoice #853146062 January 1-31, 2026	General Fund	Legal	1001-4001-53002	
1/30/2026	AMAZON MKTPL*BC5R949N3	40.71	Office Supplies	General Fund	Legal	1001-4001-56006	
2/3/2026	AMAZON.COM*543I37XN3	5.24	Office Supplies	General Fund	Legal	1001-4001-56006	
		<b>422.45</b>			<b>Legal Total</b>		
1/15/2026	ISABEL BLOOM - ECOMMERCE	48.45	Bereavement arrangement for finance employee	General Fund	City Administration	1001-4101-56033	
1/21/2026	ISABEL BLOOM - ECOMMERCE	53.88	Sympathy gift (Library)	General Fund	City Administration	1001-4101-56033	
1/22/2026	EB *ROCK ISLAND STATE	12.51	Registration for RI State of the City Address 1/29/26 - City Admns DPloehn	General Fund	City Administration	1001-4101-53004	
1/27/2026	HY-VEE BETTENDORF 1037	225.00	Bereavement arrangement (Police x 3)	General Fund	City Administration	1001-4101-56033	
1/29/2026	IACMA	800.00	2026 IMMI Conference Registration for City Administrator DPloehn & Asst City Administrator JReiter March 25-27, 2026	General Fund	City Administration	1001-4101-53004	
1/30/2026	USPS PO 1808460374	116.55	Mail Referendum Appreciation Gifts	General Fund	City Administration	1001-4101-56033	
1/30/2026	USPS PO 1808460374	38.85	Mail Referendum Appreciation Gifts	General Fund	City Administration	1001-4101-56033	
2/2/2026	HY-VEE AISLES ONLINE 4017	34.93	Water for council meetings and various other meetings.	General Fund	City Administration	1001-4101-56006	
2/5/2026	AMAZON MKTPL*5W4CQ6G43	60.05	Office Supplies	General Fund	City Administration	1001-4101-56006	
2/7/2026	AMAZON MKTPL*FO7LB2UH3	19.36	Keurig Supplies for Large Conference Room	General Fund	City Administration	1001-4101-56006	
2/9/2026	D J*WSJ	41.72	Monthly Subscription	General Fund	City Administration	1001-4101-53002	
2/12/2026	HY-VEE BETTENDORF 1037	90.00	Employee Bereavement Support (PW)	General Fund	City Administration	1001-4101-56033	
2/12/2026	PROJECTNOW.ORG	62.35	Registration 2026 Rooting Out Poverty Conf, 4/9/26 - City Admin DPloehn	General Fund	City Administration	1001-4101-53004	
2/13/2026	HY-VEE BETTENDORF 1037	90.25	Bereavement arrangement for former Mayor Frank Klipsch, City of Davenport	General Fund	City Administration	1001-4101-56033	
		<b>1,693.90</b>			<b>City Administration Total</b>		
1/16/2026	AMAZON MKTPL*JQI135E63	274.05	9 of the 33 flashlights ordered for Public Works/Parks	General Fund	Human Resources	1001-4201-55013	
1/16/2026	INQUIREHIRE	327.69	Background Screens	General Fund	Human Resources	1001-4201-55013	
1/20/2026	HANDSHAKE SUBSCRIPTION	238.00	Police Officer recruiting	General Fund	Human Resources	1001-4201-55003	
1/27/2026	HANDSHAKE SUBSCRIPTION	238.00	Recruiting tool for Police Officers	General Fund	Human Resources	1001-4201-55003	
1/27/2026	IN *IOWA SPORTS FOUNDATIO	1,225.00	Fee for participating in the 2026 Quad Cities Corporate Games	General Fund	Human Resources	1001-4201-56034	
1/31/2026	UNIV OF DUBUQUE	53.00	Registration Fee for the University of Dubuque Job Fair on February 4, 2026	General Fund	Human Resources	1001-4201-55003	
2/2/2026	INQUIREHIRE	64.20	Background Screens	General Fund	Human Resources	1001-4201-55013	
2/2/2026	PELRA* IL	50.00	Iowa Public Employer Labor Relations Association - 2026 spring conference	General Fund	Human Resources	1001-4201-53004	
2/3/2026	HANDSHAKE SUBSCRIPTION	238.00	Recruiting for Police Officers	General Fund	Human Resources	1001-4201-55003	
2/3/2026	PAY*IRON TEE GOLF	234.00	Catering for Dept Head meeting	General Fund	Human Resources	1001-4201-53004	
2/3/2026	SAMS CLUB #8238	150.20	Snacks for Dept Head meeting and budget meetings	General Fund	Human Resources	1001-4201-53004	
2/10/2026	HANDSHAKE SUBSCRIPTION	204.00	Recruiting for Police Officers	General Fund	Human Resources	1001-4201-55003	
2/11/2026	GETMEREREGISTERED EVENTS	534.83	Registration to attend Iowa Employment Conference	General Fund	Human Resources	1001-4201-53004	
2/12/2026	LEVATAI*	19.94	blank badge cards for test printing	General Fund	Human Resources	1001-4201-56006	
2/12/2026	WWW.AUGUSTANA.EDU	350.00	Payment for Attending the QC Expo '26 Job Fair at The Bend in East Moline, IL on 2/18/2026	General Fund	Human Resources	1001-4201-55003	
		<b>4,200.91</b>			<b>Human Resources Total</b>		
		<b>81,559.25</b>		<b>General Fund Total</b>			
1/15/2026	SAMS CLUB.COM	23.92	Vinegar for cleaning equipment	Road Use Fund	Public Works	2060-0502-56007	
1/17/2026	LEE NEWS SUBSCRIPTION	4.99	QC Times Subscription	Road Use Fund	Public Works	2060-0501-53002	

## Bettendorf City Council P-card Disbursements - Feb26 Statement - 03.03.26

Transaction Date	Vendor Name	Amount	Memo	Fund	Department	Account	Project
1/19/2026	AMAZON.COM*Q461L2983	49.37	Markers, Highlighters & Pens	Road Use Fund	Public Works	2060-0501-56006	
1/22/2026	SMASH PIZZERIA	101.81	SUDAS Mtg with inspectors	Road Use Fund	Public Works	2060-0502-53004	
1/26/2026	FSP*ALL INI FUN	25.00	Public Works Day - bounce house rental deposit	Road Use Fund	Public Works	2060-0501-56007	PWDAYS
1/27/2026	HOMEDEPOT.COM	83.41	50 amp receptacle	Road Use Fund	Public Works	2060-0530-56004	
1/28/2026	QUADIENT LEASING USA O	393.21	Postage Machine Rental	Road Use Fund	Public Works	2060-0501-54015	
1/29/2026	ALTORFER INC	151.96	rain gear	Road Use Fund	Public Works	2060-0511-56010	
1/29/2026	AMAZON MKTPL*WSIFX1463	31.37	Tea & Label Tape	Road Use Fund	Public Works	2060-0501-56006	
1/30/2026	AMAZON MKTPL*5Z6JZ8EH3	32.28	Graph Notebooks	Road Use Fund	Public Works	2060-0501-56006	
1/30/2026	AMAZON MKTPL*DI3502XX3	76.93	generator cover	Road Use Fund	Public Works	2060-0530-54003	
1/30/2026	FS COM INC	215.88	Fiber jumper cable	Road Use Fund	Public Works	2060-0530-56007	
2/1/2026	SAMSLUB.COM	55.32	Spoons, lens wipes, cups, hot chocolate	Road Use Fund	Public Works	2060-0501-56006	
2/2/2026	HOMEDEPOT.COM	49.94	tape measures/tool	Road Use Fund	Public Works	2060-0530-56007	
2/2/2026	SP PLOTTER PAPER DIR	87.97	Plotter Paper	Road Use Fund	Public Works	2060-0501-56006	
2/2/2026	THE HOME DEPOT #2111	225.33	Misc. hardware, and cutting tool	Road Use Fund	Public Works	2060-0530-56007	
2/3/2026	HOMEDEPOT.COM	11.97	T-Hex wrench	Road Use Fund	Public Works	2060-0530-56007	
2/4/2026	INTERNATIONAL MUNICIPA	100.00	IMSA renewal fees	Road Use Fund	Public Works	2060-0511-53001	
2/4/2026	SP PLOTTER PAPER DIR	104.26	Plotter Paper	Road Use Fund	Public Works	2060-0501-56006	
2/4/2026	TECHNIDEA CORPORATION	258.01	Service & repair for zip level	Road Use Fund	Public Works	2060-0502-56007	
2/5/2026	AMAZON MKTPL*1J2E035B3	30.39	White board for inspectors	Road Use Fund	Public Works	2060-0501-56006	
2/5/2026	THE WEBSTAIRANT STORE INC	1,560.33	Grills for PW Day	Road Use Fund	Public Works	2060-0501-56007	PWDAYS
2/6/2026	THE WEBSTAIRANT STORE INC	(79.80)	Tax Credit/Return	Road Use Fund	Public Works	2060-0501-56007	PWDAYS
2/8/2026	UPS*1Z3B3T3K0320010812	24.86	Shipping for plotter paper return	Road Use Fund	Public Works	2060-0501-56008	
2/9/2026	AMAZON MKTPL*028443ZV3	13.66	5 lead	Road Use Fund	Public Works	2060-0501-56006	
2/9/2026	KWIK STAR #1007	15.00	City vehicle wash	Road Use Fund	Public Works	2060-0501-54014	
2/9/2026	WWW.APWA.NET	210.80	APWA Membership Renewal- Schmidt	Road Use Fund	Public Works	2060-0501-53001	
2/9/2026	WWW.APWA.NET	210.80	APWA Membership Renewal - Brian Fries	Road Use Fund	Public Works	2060-0502-53002	
2/9/2026	WWW.APWA.NET	210.80	APWA Membership Renewal - Tracey Lopez	Road Use Fund	Public Works	2060-0502-53002	
2/9/2026	WWW.APWA.NET	210.80	APWA Membership Renewal - Kris Hatfield	Road Use Fund	Public Works	2060-0511-53001	
2/10/2026	FIBEROPTIC SUPPLY ECOM	2,660.00	Fiber cassettes	Road Use Fund	Public Works	2060-0530-56007	
2/10/2026	FS COM INC	195.00	Fiber jumpers	Road Use Fund	Public Works	2060-0530-56004	
2/11/2026	THE HOME DEPOT 2111	80.74	Socket	Road Use Fund	Public Works	2060-0511-56007	
		<b>7,426.31</b>		<b>Road Use Fund Total</b>			
1/15/2026	AMAZON MKTPL*X19OU0N43	21.35	FOL 9j - Tween Role-Playing Games	Library Gift Fund	Library	2260-0606-56006	
1/15/2026	CULLIGAN OF QUAD CITIES O	55.45	Water	Library Gift Fund	Library	2260-0606-56006	
1/16/2026	TARGET 00005330	10.29	FOL 11a - Winter Teen Programming snacks	Library Gift Fund	Library	2260-0606-56006	
1/19/2026	HY-VEE BETTENDORF 1037	22.65	FOL 11a - Winter Teen Programming Teen Leadership Committee Cocoa Bar	Library Gift Fund	Library	2260-0606-56006	
1/21/2026	VESTIS SERVICES LLC	74.95	First Aid Kit restock	Library Gift Fund	Library	2260-0606-56006	
1/22/2026	SP IHEARTFRUITBOX	82.49	Staff Bereavement Gift	Library Gift Fund	Library	2260-0606-56006	

## Bettendorf City Council P-card Disbursements - Feb26 Statement - 03.03.26

Transaction Date	Vendor Name	Amount	Memo	Fund	Department	Account	Project
1/22/2026	SQ *ZERO WASTE RESERVE	78.86	FOL 2g - Teen Environmental Summit supplies	Library Gift Fund	Library	2260-0606-56006	
1/24/2026	TIL*PL DBC BETTENDORF	47.06	FOL 5e - Brown Bag Lunch	Library Gift Fund	Library	2260-0606-56006	
1/26/2026	AMAZON MKTPL*1B1DT9F33	63.01	Foundation Fall 2025 Creation Studio Allocation	Library Gift Fund	Library	2260-0680-57087	
1/26/2026	AMAZON MKTPL*3M9HC6E93	49.49	FOL 2d - Preschool Fair Supplies	Library Gift Fund	Library	2260-0606-56006	
1/26/2026	AMAZON MKTPL*RQ1OP3WD3	144.17	FOL li - Seed Library supplies	Library Gift Fund	Library	2260-0606-56006	
1/26/2026	EBAY O*08-14155-03857	20.29	Staff Years of Service Award	Library Gift Fund	Library	2260-0606-56006	
1/26/2026	SOUNDRACK YOUR BRAND	648.00	FOL 12b - Soundtrack Your Brand (Music streaming service - 1 year subscription).	Library Gift Fund	Library	2260-0606-56006	
1/27/2026	TIL*PL DBC DVNPR2 220	23.53	FOL 1h - Memory Circle	Library Gift Fund	Library	2260-0606-56006	
1/28/2026	HY-VEE BETTENDORF 1037	48.20	FOL 1lf - Music and Mocktails supplies	Library Gift Fund	Library	2260-0606-56006	
1/28/2026	STERICYCLE, INC	159.72	Shredding	Library Gift Fund	Library	2260-0606-56006	
1/28/2026	VESTIS SERVICES LLC	74.95	First Aid Kit restock	Library Gift Fund	Library	2260-0606-56006	
1/29/2026	AMAZON MKTPL*7A1DV5UU3	12.99	Creation Studio Fall 2025 Foundation Allocation	Library Gift Fund	Library	2260-0680-57087	
1/29/2026	CULLIGAN OF QUAD CITIES O	44.20	Water	Library Gift Fund	Library	2260-0606-56006	
1/29/2026	HY-VEE BETTENDORF 1037	41.91	FOL 1lf - Music and Mocktails supplies	Library Gift Fund	Library	2260-0606-56006	
1/29/2026	VESTIS SERVICES LLC	74.95	First Aid Kit restock	Library Gift Fund	Library	2260-0606-56006	
1/30/2026	AMAZON MKTPL*1E72Y6GO3	17.99	Pest Traps	Library Gift Fund	Library	2260-0606-56006	
2/1/2026	AMAZON MKTPL*N90RA6TC3	172.63	FOL li - Seed Library supplies	Library Gift Fund	Library	2260-0606-56006	
2/2/2026	AMAZON MKTPL*1U0YD52B3	30.57	9g- ASK Lab supplies	Library Gift Fund	Library	2260-0606-56006	
2/2/2026	SP AMERICAN BUTTON M	484.95	Foundation Fall 2025 Creation Studio Allocation	Library Gift Fund	Library	2260-0680-57087	
2/3/2026	EZCATER*DUNN BROTHERS	23.53	FOL 1c - Coffee and Conversations	Library Gift Fund	Library	2260-0606-56006	
2/4/2026	WM SUPERCENTER #1241	16.11	FOL li - Seed Library Supplies	Library Gift Fund	Library	2260-0606-56006	
2/5/2026	LAKESHORE LEARNING MATER	1,765.92	Friends Wishlist Item 2c 2026	Library Gift Fund	Library	2260-0606-56006	
2/5/2026	WAL-MART #1241	55.86	FOL 1la - Winter Teen Programming supplies	Library Gift Fund	Library	2260-0606-56006	
2/6/2026	AMAZON MKTPL*1E2206XB3	26.69	11A- Teen Winter Programs	Library Gift Fund	Library	2260-0606-56006	

## Bettendorf City Council P-card Disbursements - Feb26 Statement - 03.03.26

Transaction Date	Vendor Name	Amount	Memo	Fund	Department	Account	Project
2/6/2026	OFFICE EXPRESS	14.67	Napkins - Lounge	Library Gift Fund	Library	2260-0606-56006	
2/6/2026	QUILL CORPORATION	39.75	Paper Towels	Library Gift Fund	Library	2260-0606-56006	
2/7/2026	AMAZON RETA* EO3IJ6PK3	24.00	FOL 10e - Lucky Day (print)	Library Gift Fund	Library	2260-0606-56006	
2/7/2026	TIL*PL DBC BETTENDORFI	47.06	FOL 5e - Brown Bag Lunch	Library Gift Fund	Library	2260-0606-56006	
2/9/2026	AMAZON MKTPL*B71BO3ZR3	80.35	Creation Studio Fall 2025 Foundation Allocation	Library Gift Fund	Library	2260-0680-57087	
2/9/2026	CULLIGAN OF QUAD CITIES O	5.00	Water	Library Gift Fund	Library	2260-0606-56006	
2/9/2026	DOLLAR GENERAL #10776	10.17	FOL 11a - Winter teen programming supplies	Library Gift Fund	Library	2260-0606-56006	
2/9/2026	VESTIS SERVICES LLC	74.95	First Aid Kit restock	Library Gift Fund	Library	2260-0606-56006	
2/10/2026	SQ *ALL-STAR ENERGY CAFE	10.00	FOL 2a - 100 Books Before Graduation Prizes	Library Gift Fund	Library	2260-0606-56006	
2/10/2026	SQ *ATLAS COLLECTIVE	10.00	FOL 2a - 100 Books Before Graduation prizes	Library Gift Fund	Library	2260-0606-56006	
2/10/2026	SQ *ATLAS COLLECTIVE	52.98	FOL 2g - Teen Environmental Summit	Library Gift Fund	Library	2260-0606-56006	
2/10/2026	SQ *QUAD CITY BOTANICAL C	15.00	FOL 2g - Teen Environmental Summit	Library Gift Fund	Library	2260-0606-56006	
2/10/2026	TST*ICONIC ENERGY BAR -	30.00	FOL 2a - 100 Books Before Graduation prizes	Library Gift Fund	Library	2260-0606-56006	
2/10/2026	WHITEYS ICE CREAM BETT	10.00	FOL 2a - 100 Books Before Graduation Prizes	Library Gift Fund	Library	2260-0606-56006	
2/12/2026	SQ *MEATBALL'S SANDWICH C	73.76	Lunch - Managers	Library Gift Fund	Library	2260-0606-56006	
2/12/2026	TST* ATOMIC COFFEE BAR -	20.00	FOL 2a - 100 Books Before Graduation Prizes 2 \$10 gift cards (2 pages attached)	Library Gift Fund	Library	2260-0606-56006	
2/12/2026	TST* ATOMIC COFFEE BAR -	15.00	FOL 2g - Teen Environmental Summit	Library Gift Fund	Library	2260-0606-56006	
2/13/2026	CULLIGAN OF QUAD CITIES O	55.45	Water	Library Gift Fund	Library	2260-0606-56006	
		<b>4,980.90</b>		<b>Library Gift Fund Total</b>			
1/15/2026	AMAZON MKTPL*1434I07N3	129.80	Fiber rack	Capital Projects	Capital Projects	4000-5050-56004	CD0112
1/20/2026	GRAINGER	1,268.55	light contactor	Capital Projects	Capital Projects	4000-5050-56007	CD0115
1/20/2026	GRAINGER	188.16	cabinet terminal blocks	Capital Projects	Capital Projects	4000-5050-56007	CD0115
1/26/2026	WESTWARD SALES	386.25	modem antenna	Capital Projects	Capital Projects	4000-5050-56004	CD0082
1/27/2026	GRAINGER	3,024.65	Lighting contactor	Capital Projects	Capital Projects	4000-5050-56007	2CD011
1/27/2026	MENARDS DAVENPORT IA	483.95	electrical panel	Capital Projects	Capital Projects	4000-5050-56007	CD0115
2/4/2026	DKC*DIGI KEY CORP	368.37	Power Block for light cabinet	Capital Projects	Capital Projects	4000-5050-56007	CD0115
2/10/2026	GRAINGER	3,948.32	Cabinet breaker	Capital Projects	Capital Projects	4000-5050-56007	CD0115
2/11/2026	FIBEROPTIC SUPPLY ECOM	1,992.00	Fiber D cases	Capital Projects	Capital Projects	4000-5050-56004	2CD005

## Bettendorf City Council P-card Disbursements - Feb26 Statement - 03.03.26

Transaction Date	Vendor Name	Amount	Memo	Fund	Department	Account	Project
2/11/2026	GRAINGER	457.20	lug for lighting cabinet	Capital Projects	Capital Projects	4000-5050-56004	CD0109
		<b>12,247.25</b>		<b>Capital Projects Total</b>			
1/16/2026	EBAY O*20-14095-35396	46.39	Radio Mounting Bracket and Tablet Mount/New Engine 1 - Two P-Card Trans combined on one invoice. Total 83.39. Ordered for Fire Department. PROJECT FD0003	Vehicle Replacement Fund	Finance	4010-0242-57074	FD0003
1/16/2026	EBAY O*20-14095-35399	37.00	Radio Mounting Bracket and Tablet Mount/New Engine 1 - Two P-Card Trans combined on one invoice. Total 83.39. Ordered for Fire Department. PROJECT FD0003	Vehicle Replacement Fund	Finance	4010-0242-57074	
1/16/2026	FIRE SAFETY USA INC	693.70	Container Holder and Diamond Blade/New Engine 1	Vehicle Replacement Fund	Finance	4010-0242-57074	FD0003
1/21/2026	WPSG, INC.	59.96	Quick Cut Replacement Blades/New Engine 1	Vehicle Replacement Fund	Finance	4010-0242-57074	FD0003
1/24/2026	WPSG, INC.	169.39	Saw Bracket w/Pad/New Engine 1	Vehicle Replacement Fund	Finance	4010-0242-57074	FD0003
		<b>1,006.44</b>		<b>Vehicle Replacement Fund Total</b>			
1/22/2026	ORACLE AMERICA, INC.	173.64	UB IMPLEMENTATION	Technology Replacement	Finance	4020-0243-57074	
2/2/2026	AMAZON MKTPL*K63946X63	144.66	USB-C splitter adapter & dock	Technology Replacement	Finance	4020-0243-56004	IT-BIT
2/11/2026	DMI* DELL K-12/GOVT	239.96	Back Packs for new rugged back packs that come with an additional discount for our Rugged laptop purchase.	Technology Replacement	Finance	4020-0243-56004	IT-BIT
		<b>558.26</b>		<b>Technology Replacement Total</b>			
1/20/2026	AMAZON MKTPL*AA7N79MY3	832.55	Battery backup spencer lift station	Sewer Utility	Public Works	5200-0510-55081	
1/27/2026	WASTE WATER EQUIPMENT	500.00	Waste Water Treatment Conference - Steve Ernst & Brendan Smith	Sewer Utility	Public Works	5200-0510-53004	
2/2/2026	GRAINGER	1,266.37	relay block and switches	Sewer Utility	Public Works	5200-0510-55081	
2/2/2026	GRAINGER	1,485.07	disconnect spencer creek lift station	Sewer Utility	Public Works	5200-0510-55081	
2/2/2026	U.S. SAWS	986.16	aluminum lid breaker & carrying shoe	Sewer Utility	Public Works	5200-0510-56007	
2/9/2026	WWW.APWA.NET	58.52	APWA Membership Renewal - Brent Morlok	Sewer Utility	Public Works	5200-0552-53001	
2/9/2026	WWW.APWA.NET	210.80	APWA Membership Renewal - Pat Lynch	Sewer Utility	Public Works	5200-0552-53002	
		<b>5,339.47</b>		<b>Sewer Utility Total</b>			
1/17/2026	VESTIS SERVICES LLC	29.98	first aid supplies	Solid Waste/Recycling Ent	Public Works	5500-0509-56010	
2/4/2026	VESTIS SERVICES LLC	59.96	First Aid Supplies	Solid Waste/Recycling Ent	Public Works	5500-0509-56010	
2/6/2026	VESTIS SERVICES LLC	29.98	First aid Service	Solid Waste/Recycling Ent	Public Works	5500-0509-56010	
2/9/2026	WWW.APWA.NET	210.80	APWA Membership Renewal - Chris Garman	Solid Waste/Recycling Ent	Public Works	5500-0509-53001	
		<b>330.72</b>		<b>Solid Waste/Recycling Ent Total</b>			
1/15/2026	GREAT WESTERN SUPPLY CO	242.05	Can Liner, Towels, TP	Family Museum	Public Works	5550-0524-56007	2601FM
1/15/2026	GREENWOOD CLEANING SYSTE	216.61	Gloves, Cups, Towels	Family Museum	Public Works	5550-0524-56007	2601FM
1/16/2026	K & K TRUE VALUE	8.79	Faucet Parts	Family Museum	Public Works	5550-0523-54001	2600FM
1/17/2026	VESTIS SERVICES LLC	71.60	Entry Rug Service	Family Museum	Public Works	5550-0524-55081	2601FM
1/20/2026	STATE SUPPLY COMPANY IN	3,226.43	New faucets - all restrooms	Family Museum	Public Works	5550-0523-54001	2600FM
1/24/2026	VESTIS SERVICES LLC	71.60	entry rug service	Family Museum	Public Works	5550-0524-55081	2601FM
1/27/2026	ADEL WHOLESALERS INC	145.30	faucet connectors	Family Museum	Public Works	5550-0523-54001	2600FM
1/27/2026	ADEL WHOLESALERS INC	208.42	Faucet Install Parts	Family Museum	Public Works	5550-0523-54001	2600FM
1/29/2026	AMERICAN WATER WORKS COMP	113.85	Faye's Field	Family Museum	Public Works	5550-0523-54011	
2/2/2026	GREAT WESTERN SUPPLY CO	241.08	wipe, burnish pads, towels	Family Museum	Public Works	5550-0524-56007	2601FM
2/2/2026	GREAT WESTERN SUPPLY CO	220.56	towels, liners, vacuum supplies	Family Museum	Public Works	5550-0524-56007	2601FM
2/4/2026	VESTIS SERVICES LLC	71.60	Entry Rug Service	Family Museum	Public Works	5550-0524-55081	2601FM

## Bettendorf City Council P-card Disbursements - Feb26 Statement - 03.03.26

Transaction Date	Vendor Name	Amount	Memo	Fund	Department	Account	Project
2/5/2026	AMERICAN WATER WORKS COMP	501.16	Water Service	Family Museum	Public Works	5550-0523-54011	2600FM
2/5/2026	GREENWOOD CLEANING SYSTE	97.32	Disinfectant, Soap, TP	Family Museum	Public Works	5550-0524-56007	2601FM
2/6/2026	VESTIS SERVICES LLC	71.60	Entry Rug Service	Family Museum	Public Works	5550-0524-55081	2601FM
2/9/2026	GREENWOOD CLEANING SYSTE	183.80	Hand Soap	Family Museum	Public Works	5550-0524-56007	2601FM
2/9/2026	WCI*MILLENNIUM WASTE	159.15	Dumpster Service	Family Museum	Public Works	5550-0523-55081	2600FM
2/14/2026	VESTIS SERVICES LLC	71.60	Entry Rug Service	Family Museum	Public Works	5550-0524-55081	2601FM
1/15/2026	AMAZON MKTPL*E34LS8ET3	7.49	Balloons for Spring Break Activity	Family Museum	Family Museum	5550-1102-56007	
1/15/2026	AMAZON MKTPL*GV99T4V73	41.56	Cleaning Supplies for Building Maintenance	Family Museum	Family Museum	5550-1101-54006	
1/15/2026	AMAZON MKTPL*T47UB7973	113.90	Fire Station - Two New Costume to replace old costume size 6/8	Family Museum	Family Museum	5550-1102-54024	
1/15/2026	DOLLAR GENERAL #10776	13.50	Preschool: Shaving cream for puffy paint and Alka-Seltzer for science experiment	Family Museum	Family Museum	5550-1102-56007	
1/16/2026	AMAZON MKTPL*E27AZIOF3	69.95	Fire Station - New Costume Size 8/10 to Replace Old Costume	Family Museum	Family Museum	5550-1102-54024	
1/17/2026	WEISSMAN'S THEATRICAL SU	(21.28)	costume refund for exchange order	Family Museum	Family Museum	5550-1102-56030	
1/17/2026	WEISSMAN'S THEATRICAL SU	(579.96)	costume refund for exchange order	Family Museum	Family Museum	5550-1102-56030	
1/19/2026	AMAZON MKTPL*G96IA5I23	26.81	HDMI Cord for Combine SD Card Player and HDMI 90 Degree Adapter	Family Museum	Family Museum	5550-1102-56007	
1/19/2026	AMAZON MKTPLACE PMTS	(31.99)	Costume refund - never received	Family Museum	Family Museum	5550-1102-56030	
1/19/2026	IN *TOTAL ENVIRONMENTAL S	75.00	Rivers - Water Table Chemistry Testing	Family Museum	Family Museum	5550-1102-54024	
1/20/2026	AMAZON MKTPL*6G8S15GQ3	54.35	Preschool art materials	Family Museum	Family Museum	5550-1102-56007	
1/20/2026	AMERICAN ASSOC OF MUSEUM	50.00	Strategic Planning Toolkit from AAM	Family Museum	Family Museum	5550-1101-56006	
1/21/2026	AMAZON MKTPL*187XQ0PL3	13.98	book for superhero class	Family Museum	Family Museum	5550-1102-56007	
1/21/2026	AMAZON MKTPL*1TIT936V3	5.82	book for superhero class	Family Museum	Family Museum	5550-1102-56007	
1/21/2026	AMAZON MKTPL*YT4XB3V03	41.25	General Education Office Supplies - Paper Plates	Family Museum	Family Museum	5550-1102-56007	
1/21/2026	AMAZON RETA* 696OK95B3	5.58	book for superhero class	Family Museum	Family Museum	5550-1102-56007	
1/21/2026	AMAZON RETA* 9B3488RD3	15.29	General Education Office Supplies - Baby Wipes	Family Museum	Family Museum	5550-1102-56007	
1/21/2026	CULLIGAN OF QUAD CITIES O	36.70	Water at the Museum	Family Museum	Family Museum	5550-1101-56007	
1/22/2026	AMAZON MKTPL*P24098M43	29.97	Preschool wooden snakes to paint	Family Museum	Family Museum	5550-1102-56007	
1/22/2026	NICEBADGE.COM	50.45	Name tags for new staff	Family Museum	Family Museum	5550-1102-56004	
1/23/2026	REVDANCE.TENTH HOUSE	313.75	costume exchange order	Family Museum	Family Museum	5550-1102-56030	
1/23/2026	USPS PO 1808460374	32.50	costume return shipping	Family Museum	Family Museum	5550-1102-56030	
1/23/2026	WEISSMAN'S THEATRICAL SU	199.83	costume exchange order	Family Museum	Family Museum	5550-1102-56030	
1/25/2026	AMAZON MKTPL*0270Y63E3	43.17	3 - 1" Double Sided Mounting Tape	Family Museum	Family Museum	5550-1102-56007	
1/25/2026	AMAZON MKTPL*MYIM34G03	41.98	Oversized Sunglass for Hand and Hand Prom	Family Museum	Family Museum	5550-1105-56007	
1/25/2026	AMAZON MKTPL*T33XH1E3	73.13	Case for sound board case for speaker	Family Museum	Family Museum	5550-1102-56007	
1/25/2026	AMAZON MKTPL*WFF3H7933	57.54	6 - 1/2" Double Sided Mounting Tape	Family Museum	Family Museum	5550-1102-56007	
1/26/2026	AMAZON MKTPL*240W64PT3	204.79	Art Academy Supplies	Family Museum	Family Museum	5550-1102-56007	
1/26/2026	AMAZON MKTPL*XM5K34JI3	8.81	Art Academy Supplies	Family Museum	Family Museum	5550-1102-56007	
1/27/2026	AMAZON MKTPL*4C13LIL23	7.23	Art Academy Supplies	Family Museum	Family Museum	5550-1102-56007	
1/27/2026	AMAZON MKTPL*E71GJ9IR3	39.09	Tube Cutter and Magnetic Modular Organizer	Family Museum	Family Museum	5550-1102-56007	
1/27/2026	LAKESHORE LEARNING MATER	104.46	Preschool literacy and building manipulatives	Family Museum	Family Museum	5550-1102-56007	
1/27/2026	PLAY VISIONS INC	219.00	Gift shop merchandise	Family Museum	Family Museum	5550-1105-56046	
1/27/2026	RI NOVELTY/TOY NETWORK	251.85	Gift Shop Merchandise	Family Museum	Family Museum	5550-1105-56046	
1/28/2026	AMAZON MKTPL*799FKIJ43	32.28	2 - 12Volt 10Amp Power Supplies 110V-12DC	Family Museum	Family Museum	5550-1102-54024	

## Bettendorf City Council P-card Disbursements - Feb26 Statement - 03.03.26

Transaction Date	Vendor Name	Amount	Memo	Fund	Department	Account	Project
1/28/2026	AMAZON MKTPL*C30WV6V13	40.75	Break Away Claps for Pith Helmet Fuse Extractor Set Pliers Organizer Rack	Family Museum	Family Museum	5550-1102-56007	
1/28/2026	AMAZON MKTPLACE PMTS	(29.99)	costume refund	Family Museum	Family Museum	5550-1102-56030	
1/28/2026	AMAZON RETA* RUIXM54G3	34.97	Preschool cash register for grocery store	Family Museum	Family Museum	5550-1102-56007	
1/28/2026	BIGJIGS TOYS FAIRE	622.29	Fox Hollow Props	Family Museum	Family Museum	5550-1102-54024	
1/28/2026	GREEN TOYS FAIRE	320.80	Water Table and Dig Zone Props	Family Museum	Family Museum	5550-1102-54024	
1/28/2026	HACHETTE BOOK GR FAIRE	156.86	Gift shop merchandise	Family Museum	Family Museum	5550-1105-56046	
1/28/2026	JACK RABBIT CREA FAIRE	528.68	Gift shop merchandise	Family Museum	Family Museum	5550-1105-56046	
1/28/2026	KAWAII SLIME COM FAIRE	296.54	Gift shop merchandise	Family Museum	Family Museum	5550-1105-56046	
1/28/2026	TEDCO TOYS FAIRE	401.92	Gift shop merchandise	Family Museum	Family Museum	5550-1105-56046	
1/28/2026	THIRD ST STUDIO FAIRE	81.51	Gift shop merchandise	Family Museum	Family Museum	5550-1105-56046	
1/29/2026	MKT*HEEBIE JEEBIES	228.00	Store merchandise	Family Museum	Family Museum	5550-1105-56046	
1/30/2026	CULLIGAN OF QUAD CITIES O	36.70	Museum - Water	Family Museum	Family Museum	5550-1101-56007	
1/30/2026	WEISSMAN'S THEATRICAL SU	(180.20)	refund from costume exchange	Family Museum	Family Museum	5550-1102-56030	
1/31/2026	HOBBY-LOBBY #0168	23.02	Valentine supplies for 3's and 4's	Family Museum	Family Museum	5550-1102-56007	
2/1/2026	AMAZON MKTPL*RJ76C3XJ3	28.49	bar code scanner	Family Museum	Family Museum	5550-1105-56007	
2/1/2026	AMAZON MKTPL*YG3P13H93	16.14	Speaker Cover for new Speaker	Family Museum	Family Museum	5550-1102-56007	
2/1/2026	SPOTIFY P3EF11B056	21.39	Monthly Music Subscription	Family Museum	Family Museum	5550-1102-56007	
2/2/2026	CULLIGAN OF QUAD CITIES O	10.00	Museum - Water	Family Museum	Family Museum	5550-1101-56007	
2/3/2026	LEE ENT ADVERTISING AP	1,239.00	Visit Quad Cities' yearly visitor guide publication and website placement	Family Museum	Family Museum	5550-1105-55002	
2/4/2026	AMAZON RETA* 2O5VD6LZ3	24.98	Batteries for Maintenance	Family Museum	Family Museum	5550-1101-54006	
2/4/2026	WM SUPERCENTER #1241	47.74	Cooking supplies for Spanish Class	Family Museum	Family Museum	5550-1102-56007	
2/5/2026	AMAZON MKTPL*GZ9CF0XN3	10.29	Preschool gems and Valentine's Day Cards	Family Museum	Family Museum	5550-1102-56007	
2/5/2026	MCMMASTER-CARR	45.01	1-1/4" Nails 3000 1/2" Nails 7000	Family Museum	Family Museum	5550-1102-56007	
2/5/2026	THE HOME DEPOT #2111	36.40	Muriatic Acid, PL300 Foam Adhesive	Family Museum	Family Museum	5550-1102-54024	
2/6/2026	AMAZON RETA* I655X4NR3	107.04	Hand Sanitizer for restrooms	Family Museum	Family Museum	5550-1101-54001	
2/6/2026	HOBBY-LOBBY #0168	14.23	Accessories for classes	Family Museum	Family Museum	5550-1102-56030	
2/6/2026	REVDANCE.TENTH HOUSE	78.95	Costume exchange order	Family Museum	Family Museum	5550-1102-56030	
2/6/2026	REVDANCE.TENTH HOUSE	63.95	costume exchange order	Family Museum	Family Museum	5550-1102-56030	
2/7/2026	AMAZON MKTPL*DB8F57D53	13.99	Dance summer camp book	Family Museum	Family Museum	5550-1102-56007	
2/7/2026	SPOTIFY P3FIFD69AB	12.83	Museum - Imagination Studio Music App	Family Museum	Family Museum	5550-1102-56007	
2/8/2026	AMAZON MKTPL*IY6M30EE3	79.54	Polyfoil, Foam Brushes, Utility knives, Wire Brushes	Family Museum	Family Museum	5550-1102-56007	
2/8/2026	AMAZON MKTPL*ZTKD3KT3	42.52	Accessories for classes	Family Museum	Family Museum	5550-1102-56030	
2/8/2026	AMAZON RETA* 8785N3A13	45.08	Dance summer camp books	Family Museum	Family Museum	5550-1102-56007	
2/9/2026	AMAZON MKTPL*AX0SX4QO3	22.99	Replacement Wheels for office chair	Family Museum	Family Museum	5550-1101-56006	
2/10/2026	AMAZON MKTPL*EP09C2JF3	35.99	Organizer for Imagination Studio	Family Museum	Family Museum	5550-1102-56007	
2/10/2026	NAEIR, INC.	435.00	Toddler Blocks for Play House	Family Museum	Family Museum	5550-1102-54024	
2/11/2026	AMAZON MKTPL*438FK6I43	49.86	Scrapbook Paper Organizer for Imagination Studio	Family Museum	Family Museum	5550-1102-56007	
2/11/2026	AMAZON MKTPL*FM77104M3	39.96	Tattoos for Spring Break Mario Day	Family Museum	Family Museum	5550-1102-56007	
2/11/2026	DBC*BLICK ART MATERIAL	707.36	Imagination Studio Supplies	Family Museum	Family Museum	5550-1102-56007	
2/11/2026	DBC*BLICK ART MATERIAL	80.39	Imagination Studio Supplies	Family Museum	Family Museum	5550-1102-56007	
2/11/2026	K & K TRUE VALUE	253.20	Imagination Studio Wood Supply	Family Museum	Family Museum	5550-1102-56007	
2/12/2026	AMAZON MKTPL*UN5NJOKE3	15.99	Thread Checker Tool for Metric and SAE size nuts and bolts	Family Museum	Family Museum	5550-1102-56007	

## Bettendorf City Council P-card Disbursements - Feb26 Statement - 03.03.26

Transaction Date	Vendor Name	Amount	Memo	Fund	Department	Account	Project
2/12/2026	AMAZON MKTPL*XR3RC1UN3	31.61	Compressed Air for cleaning electronics	Family Museum	Family Museum	5550-1102-56007	
2/12/2026	GEO	315.28	Store merchandise	Family Museum	Family Museum	5550-1105-56046	
2/13/2026	CULLIGAN OF QUAD CITIES O	44.20	Museum - Water	Family Museum	Family Museum	5550-1101-56007	
		<b>14,101.55</b>		<b>Family Museum Total</b>			
1/20/2026	HANKS SPECIALTIES - DAVEN	33.36	doorway threshold material	Palmer Hills Golf Course	Public Works	5600-0523-54001	2600GC
1/21/2026	HANKS SPECIALTIES - DAVEN	33.36	carpet threshold	Palmer Hills Golf Course	Public Works	5600-0523-54001	2600GC
1/21/2026	K & K TRUE VALUE	16.36	chair rail board	Palmer Hills Golf Course	Public Works	5600-0523-54001	2600GC
1/22/2026	VESTIS SERVICES LLC	25.00	entry rug service	Palmer Hills Golf Course	Public Works	5600-0524-55081	2601GC
1/24/2026	VESTIS SERVICES LLC	25.00	entry rug service	Palmer Hills Golf Course	Public Works	5600-0524-55081	2601GC
1/26/2026	MENARDS DAVENPORT IA	34.77	slot wall guides	Palmer Hills Golf Course	Public Works	5600-0523-54001	2600GC
1/27/2026	MENARDS DAVENPORT IA	(34.77)	product returned	Palmer Hills Golf Course	Public Works	5600-0523-54001	2600GC
1/29/2026	AMERICAN WATER WORKS COMP	63.65	fire protection water service	Palmer Hills Golf Course	Public Works	5600-0523-54011	2600GC
1/29/2026	AMERICAN WATER WORKS COMP	134.64	water service	Palmer Hills Golf Course	Public Works	5600-0523-54011	2600GC
2/4/2026	VESTIS SERVICES LLC	25.00	Entry Rug Service	Palmer Hills Golf Course	Public Works	5600-0524-55081	2601GC
2/4/2026	VESTIS SERVICES LLC	25.00	Entry Rug Service	Palmer Hills Golf Course	Public Works	5600-0524-55081	2601GC
2/10/2026	AMERICAN WATER WORKS COMP	63.65	Fire Protection Water Service	Palmer Hills Golf Course	Public Works	5600-0523-54011	2600GC
2/12/2026	VESTIS SERVICES LLC	25.00	Rug Service	Palmer Hills Golf Course	Public Works	5600-0524-55081	2601GC
1/15/2026	AUTOZONE #1908	54.95	Filters	Palmer Hills Golf Course	Parks	5600-0715-54006	
1/15/2026	AUTOZONE #1908	65.94	Oil	Palmer Hills Golf Course	Parks	5600-0715-56035	
1/15/2026	KUNAU IMPLEMENT - DEWITT	200.40	Oil filters	Palmer Hills Golf Course	Parks	5600-0715-54006	
1/15/2026	KUNAU IMPLEMENT - DEWITT	843.72	Oil	Palmer Hills Golf Course	Parks	5600-0715-56035	
1/20/2026	ADVANCE AUTO PARTS #3365	17.28	Spark plugs	Palmer Hills Golf Course	Parks	5600-0715-54006	
1/20/2026	MENARDS DAVENPORT IA	378.81	Hex key, grabber, wash mitt, knives, cable ties, blades, usb charger, brushes, putty, bucket, towels and caddy	Palmer Hills Golf Course	Parks	5600-0715-56007	
1/20/2026	QUAD CITY SAFETY INC	584.01	Earplugs, bug spray, gloves, lens wipes, safety glasses and sun block	Palmer Hills Golf Course	Parks	5600-0715-56010	
1/22/2026	MTI	1,041.20	Wheels, wheel bearings and a roller	Palmer Hills Golf Course	Parks	5600-0715-54006	
1/26/2026	PGA OF AMERICA MEMBERS	750.00	Alex Grell - PGA PGM Level 1 Seminar	Palmer Hills Golf Course	Parks	5600-0711-53004	
1/27/2026	AUTOZONE #1908	17.24	Belt for air compressor	Palmer Hills Golf Course	Parks	5600-0715-54006	
1/27/2026	K & K TRUE VALUE	66.35	Grinding wheels	Palmer Hills Golf Course	Parks	5600-0715-54006	
1/27/2026	K & K TRUE VALUE	29.02	2-cycle oil	Palmer Hills Golf Course	Parks	5600-0715-56035	
1/27/2026	K & K TRUE VALUE	36.87	mop and refills	Palmer Hills Golf Course	Parks	5600-0715-56007	
1/28/2026	M & M GOLF CARS LLC - BETT	6.88	Bushings	Palmer Hills Golf Course	Parks	5600-0715-54006	
1/30/2026	MTI	23.06	Hollow allen fittings	Palmer Hills Golf Course	Parks	5600-0715-54006	
2/1/2026	FSP*AVANTI INTERNATIONAL	748.15	Hotel for GCSSA Conference	Palmer Hills Golf Course	Parks	5600-0715-53004	
2/2/2026	AMERICAN WATER WORKS COMP	29.14	PHGC Maint	Palmer Hills Golf Course	Parks	5600-0715-54011	
2/2/2026	MENARDS DAVENPORT IA	71.32	Key tags, cleaning supplies, light bulbs	Palmer Hills Golf Course	Parks	5600-0715-56007	
2/2/2026	SPI*DIRECTV SERVICE	158.34	Satellite Tv	Palmer Hills Golf Course	Parks	5600-0711-54009	
2/3/2026	MCCORD GOLF SAFETY	300.00	Annual Safety Videos	Palmer Hills Golf Course	Parks	5600-0715-55081	
2/3/2026	O'REILLY 701	4.49	Oil drain plug	Palmer Hills Golf Course	Parks	5600-0715-54006	
2/4/2026	SQ *GOLF COURSE SUPERINTE	141.43	Educational materials - Turfgrass Management	Palmer Hills Golf Course	Parks	5600-0715-53002	
2/5/2026	VAN WALL EQUIPMENT	1,765.18	Rake handles, rake heads, rake grips & flagsticks	Palmer Hills Golf Course	Parks	5600-0715-56007	
2/7/2026	PY *AUDUBON INTERNATIONAL	500.00	Audubon International Membership Renewal 2026-2027	Palmer Hills Golf Course	Parks	5600-0715-53001	
2/12/2026	SQ *GOLF COURSE SUPERINTE	(8.63)	Tax Refund for Educational materials - Turfgrass Management	Palmer Hills Golf Course	Parks	5600-0715-53002	
2/12/2026	VAN WALL EQUIPMENT	70.80	Belts for the 220C walk mowers	Palmer Hills Golf Course	Parks	5600-0715-54006	

## Bettendorf City Council P-card Disbursements - Feb26 Statement - 03.03.26

Transaction Date	Vendor Name	Amount	Memo	Fund	Department	Account	Project
2/13/2026	ULINE *SHIP SUPPLIES	101.33	GRADUATED MIXING PAIL	Palmer Hills Golf Course	Parks	5600-0715-56007	
		<b>8,467.30</b>		<b>Palmer Hills Golf Course Total</b>			
2/2/2026	AMERICAN WATER WORKS COMP	496.06	frozen landing water	Aquatic Center Fund	Public Works	5750-0525-54011	2500IR
2/10/2026	AMERICAN WATER WORKS COMP	112.65	2255 Middle Rd	Aquatic Center Fund	Public Works	5750-0525-54011	2600IR
		<b>608.71</b>		<b>Aquatic Center Fund Total</b>			
1/21/2026	AMERICAN WATER WORKS COMP	53.60	Sweeper water	Storm Water Utility	Public Works	5800-0583-54011	2600CH
1/26/2026	EB *12TH ANNUAL QUAD C	45.00	QC Stormwater Conference Registration	Storm Water Utility	Public Works	5800-0582-53004	
1/29/2026	EB *12TH ANNUAL QUAD C	45.00	QC Stormwater Conference	Storm Water Utility	Public Works	5800-0581-53004	
1/29/2026	EB *12TH ANNUAL QUAD C	315.00	QC Stormwater Conference Registration: Dave Merritt, Tony Rodriguez, Brian Verhelst, Nick Young, Nate Chapman, Larry Gregorich and Brian Fries	Storm Water Utility	Public Works	5800-0582-53004	
1/30/2026	MACQUEEN EMERG/EQUIP	367.50	headset repair service	Storm Water Utility	Public Works	5800-0519-55081	
1/30/2026	MACQUEEN EMERG/EQUIP	367.50	headset repair service	Storm Water Utility	Public Works	5800-0519-55081	
2/9/2026	WWW.APWA.NET	152.28	APWA Membership Renewal - Brent Morlok	Storm Water Utility	Public Works	5800-0582-53001	
2/9/2026	WWW.APWA.NET	210.80	APWA Membership Renewal - Todd Hildebrandt	Storm Water Utility	Public Works	5800-0519-53001	
1/26/2026	COLUMN PUBLIC NOTICE	28.18	Notice of Intent - Pigeon Creek	Storm Water Utility	Capital Projects	5800-5059-55014	SM0156
1/28/2026	IA DNR FEES AND PAYMENTS	180.91	NPDES Permit - Pigeon Creek	Storm Water Utility	Capital Projects	5800-5059-56007	SM0156
		<b>1,765.77</b>		<b>Storm Water Utility Total</b>			
1/29/2026	AMERICAN WATER WORKS COMP	448.65	bus wash water	Transit	Public Works	5850-0547-54011	
2/9/2026	WWW.APWA.NET	210.80	APWA Membership Renewal - Austin Whelan	Transit	Public Works	5850-0507-53001	
2/10/2026	AMAZON MKTPL*VP4EL7L03	31.96	5/8" Cam Lock	Transit	Public Works	5850-0527-54003	
2/11/2026	FASTENAL COMPANY OIABET	19.80	Bus Wash - Snap ring Clips	Transit	Public Works	5850-0557-56007	
2/11/2026	OFFICE EXPRESS	43.34	Office Supplies- Binder and Pens	Transit	Public Works	5850-0507-56006	
		<b>754.55</b>		<b>Transit Total</b>			
1/14/2026	NAPA STORE 3137121	23.50	Filter & Bulb STK	Municipal Garage	Public Works	6830-0520-56024	
1/15/2026	GRAINGER	8.10	operating supplies	Municipal Garage	Public Works	6830-0520-56007	
1/15/2026	K & K TRUE VALUE	91.87	operating supplies	Municipal Garage	Public Works	6830-0520-56007	
1/16/2026	AMAZON MKTPL*1I12G4Q53	450.60	Pintle Mount	Municipal Garage	Public Works	6830-0520-56024	
1/16/2026	AMAZON MKTPL*CH8NG8BN3	17.98	RAM mounts	Municipal Garage	Public Works	6830-0520-56024	
1/17/2026	VESTIS SERVICES LLC	29.98	First Aid	Municipal Garage	Public Works	6830-0520-56010	
1/17/2026	VESTIS SERVICES LLC	65.27	Laundry	Municipal Garage	Public Works	6830-0520-55026	
1/21/2026	NAPA STORE 3137121	6.12	filter	Municipal Garage	Public Works	6830-0520-56024	
1/21/2026	NAPA STORE 3137121	9.64	washer cap	Municipal Garage	Public Works	6830-0520-56024	
1/23/2026	GRAINGER	133.16	trailer hook	Municipal Garage	Public Works	6830-0520-56024	
1/23/2026	NAPA STORE 3137121	(122.05)	return	Municipal Garage	Public Works	6830-0520-56024	
1/23/2026	NAPA STORE 3137121	362.37	stock filters	Municipal Garage	Public Works	6830-0520-56024	
1/23/2026	THE HOME DEPOT #2111	46.32	dyable, caulk	Municipal Garage	Public Works	6830-0520-56024	
1/26/2026	NAPA STORE 3137121	103.02	hose	Municipal Garage	Public Works	6830-0520-56024	
1/28/2026	AMAZON MKTPL*ME72B94K3	871.56	impact air wrench	Municipal Garage	Public Works	6830-0520-56004	
1/28/2026	NAPA STORE 3137121	53.17	stock filters	Municipal Garage	Public Works	6830-0520-56024	
1/28/2026	NAPA STORE 3137121	13.24	filter	Municipal Garage	Public Works	6830-0520-56024	
1/28/2026	NAPA STORE 3137121	74.97	operating supplies	Municipal Garage	Public Works	6830-0520-56007	
1/29/2026	NAPA STORE 3137121	150.05	blower motor - 1617	Municipal Garage	Public Works	6830-0520-56024	
1/30/2026	AMAZON MKTPL*WG8A07B73	140.00	laptop protection plan - 3 year	Municipal Garage	Public Works	6830-0520-56004	
1/30/2026	AMAZON MKTPL*WG8A07B73	139.99	laptop protection plan - 3 year	Municipal Garage	Public Works	6830-0520-56007	

## Bettendorf City Council P-card Disbursements - Feb26 Statement - 03.03.26

Transaction Date	Vendor Name	Amount	Memo	Fund	Department	Account	Project
1/30/2026	AMAZON MKTPL*X32UG35U3	1,500.00	dell laptop	Municipal Garage	Public Works	6830-0520-56004	
1/30/2026	AMAZON MKTPL*X32UG35U3	1,043.31	dell laptop	Municipal Garage	Public Works	6830-0520-56007	
1/30/2026	NAPA STORE 3137121	(13.24)	return - oil filter	Municipal Garage	Public Works	6830-0520-56024	
2/3/2026	GRAINGER	33.60	operating supplies	Municipal Garage	Public Works	6830-0520-56007	
2/3/2026	NAPA STORE 3137121	23.49	Filters	Municipal Garage	Public Works	6830-0520-56024	
2/4/2026	GRAINGER	854.16	STK Light	Municipal Garage	Public Works	6830-0520-56024	
2/4/2026	NAPA STORE 3137121	142.00	Operating Supplies	Municipal Garage	Public Works	6830-0520-56007	
2/4/2026	NAPA STORE 3137121	17.44	Box	Municipal Garage	Public Works	6830-0520-56024	
2/4/2026	NAPA STORE 3137121	17.85	Air Filter	Municipal Garage	Public Works	6830-0520-56024	
2/4/2026	THE HOME DEPOT 2111	97.24	Pipe & Bolts	Municipal Garage	Public Works	6830-0520-56024	
2/5/2026	NAPA STORE 3137121	7.95	STK bracket	Municipal Garage	Public Works	6830-0520-56024	
2/5/2026	NAPA STORE 3137121	70.88	STK Filters	Municipal Garage	Public Works	6830-0520-56024	
2/5/2026	THE HOME DEPOT #2111	15.72	U-Bolt	Municipal Garage	Public Works	6830-0520-56007	
2/6/2026	NAPA STORE 3137121	22.46	STK Filters	Municipal Garage	Public Works	6830-0520-56024	
2/9/2026	AMAZON MKTPL*Y22PD7KR3	64.74	Laptop battery	Municipal Garage	Public Works	6830-0520-56006	
2/9/2026	NAPA STORE 3137121	(144.51)	Return	Municipal Garage	Public Works	6830-0520-56024	
2/9/2026	NAPA STORE 3137121	24.76	Filter	Municipal Garage	Public Works	6830-0520-56024	
2/9/2026	NAPA STORE 3137121	347.89	Starter & Mats	Municipal Garage	Public Works	6830-0520-56024	
2/9/2026	NAPA STORE 3137121	233.70	Operating Supplies	Municipal Garage	Public Works	6830-0520-56007	
2/9/2026	VESTIS SERVICES LLC	29.98	First Aid	Municipal Garage	Public Works	6830-0520-56010	
2/9/2026	VESTIS SERVICES LLC	65.27	Laundry	Municipal Garage	Public Works	6830-0520-55026	
2/9/2026	VESTIS SERVICES LLC	65.27	Laundry	Municipal Garage	Public Works	6830-0520-55026	
2/9/2026	VESTIS SERVICES LLC	29.98	First Aid	Municipal Garage	Public Works	6830-0520-56010	
2/9/2026	VESTIS SERVICES LLC	65.27	Laundry	Municipal Garage	Public Works	6830-0520-55026	
2/9/2026	VESTIS SERVICES LLC	29.98	First Aid	Municipal Garage	Public Works	6830-0520-56010	
2/9/2026	WWW.APWANET	210.80	APWA Membership Renewal - Oscar Herrera	Municipal Garage	Public Works	6830-0520-53001	
2/10/2026	NAPA STORE 3137121	28.85	Filters STK	Municipal Garage	Public Works	6830-0520-56024	
2/10/2026	NAPA STORE 3137121	9.00	Wiper 1301	Municipal Garage	Public Works	6830-0520-56024	
2/11/2026	GRAINGER	200.39	Operating Supplies	Municipal Garage	Public Works	6830-0520-56007	
2/11/2026	NAPA STORE 3137121	23.88	STK Filters	Municipal Garage	Public Works	6830-0520-56024	
2/11/2026	SPORT TRUCK SPECIALTIES I	946.00	Tool Box	Municipal Garage	Public Works	6830-0520-56024	
2/12/2026	GRAINGER	36.64	Operating Supplies	Municipal Garage	Public Works	6830-0520-56007	
2/12/2026	NAPA STORE 3137121	61.25	TPMS Sensor	Municipal Garage	Public Works	6830-0520-56024	
2/13/2026	NAPA STORE 3137121	53.07	Horns 1612	Municipal Garage	Public Works	6830-0520-56024	
2/13/2026	NAPA STORE 3137121	16.65	STK Filters	Municipal Garage	Public Works	6830-0520-56024	
2/13/2026	POWER TOOL REPAIR	103.90	Operating Supplies	Municipal Garage	Public Works	6830-0520-56007	
2/13/2026	THE HOME DEPOT #2111	15.92	Pads	Municipal Garage	Public Works	6830-0520-56007	
2/14/2026	VESTIS SERVICES LLC	65.27	Laundry	Municipal Garage	Public Works	6830-0520-55026	
2/14/2026	VESTIS SERVICES LLC	29.98	First Aid	Municipal Garage	Public Works	6830-0520-56010	
		<b>9,115.65</b>		<b>Municipal Garage Total</b>			
2/10/2026	FLAGPOLES, INCORPORATE	1,858.00	Accident Pole 25-16672	Risk Management	Mayor & Council	6840-0105-55058	
		<b>1,858.00</b>		<b>Risk Management Total</b>			
1/15/2026	ADOBE INC	29.99	Stock photo subscription used for marketing graphics.	Information Services	Finance	6880-0231-56019	IT-555
1/15/2026	AMAZON MKTPL*GF7980J33	10.89	5 meter multi-mode fiber patch cable	Information Services	Finance	6880-0231-56004	IT-FIN
1/15/2026	AMAZON MKTPL*SV4X62483	85.98	CradlePoint Cell antennas, GPS, and wi-fi antennas.	Information Services	Finance	6880-0231-56004	

## Bettendorf City Council P-card Disbursements - Feb26 Statement - 03.03.26

Transaction Date	Vendor Name	Amount	Memo	Fund	Department	Account	Project
1/16/2026	S- METRONET WH IVR	108.05	Bridge Cam Internet January 2026	Information Services	Finance	6880-0231-54010	IT-FIN
1/17/2026	HAVE I BEEN PWNEED	1,630.00	HaveBeenPwned - Software subscription for Jan 18, 2026 - Jan 18, 2027	Information Services	Finance	6880-0231-55023	IT-BIT
1/21/2026	ORACLE AMERICA, INC.	56.28	ADDITIONAL USERS	Information Services	Finance	6880-0231-55023	
1/21/2026	ORACLE AMERICA, INC.	40,657.67	SOFTWARE SERVICE	Information Services	Finance	6880-0231-55023	
1/21/2026	SQ *CTI	183.60	Council Chambers equipment repair call with 3% credit card surcharge	Information Services	Finance	6880-0231-55072	IT-FIN
1/23/2026	CENTURYLINK LUMEN	635.13	Internet January 2026	Information Services	Finance	6880-0231-54010	IT-FIN
1/24/2026	COUCHDROP MOVEBOT	240.00	CouchDrop Secure FTP used for NS4G integrations.	Information Services	Finance	6880-0231-55023	IT-FIN
1/24/2026	MSFT * E0400YBMRO	26.75	Microsoft 365 reporting and analysis tools monthly subscription	Information Services	Finance	6880-0231-55023	IT-FIN
1/24/2026	MSFT * E0400YBP74	8.56	Teams share device account used for City Council Chambers	Information Services	Finance	6880-0231-55023	IT-EDV
1/24/2026	MSFT * E0400YBPW1	252.00	Microsoft G3 licenses add-on subscriptions to cover added employees.	Information Services	Finance	6880-0231-55023	IT-FIN
1/27/2026	CLOUD COVER MUSIC	37.90	Commercial music subscription for parks used at Palmer Hills and Ice Rink.	Information Services	Finance	6880-0231-55023	IT-PKS
1/29/2026	CCI*CONSTANT-CONTACT	328.60	Communication software subscription for keeping citizens informed - 11.29.25 - 12.29.25	Information Services	Finance	6880-0231-55023	
1/29/2026	LEXISNEXIS RISK SOL	206.00	Monthly Subscription	Information Services	Finance	6880-0231-55023	
1/30/2026	BARCODES GROUP, INC.	914.28	Network-enabled Printers for our squad cars with quantity 2.	Information Services	Finance	6880-0231-56004	IT-POL
1/31/2026	REBRANDLY.COM	29.00	Domain name forwarding services	Information Services	Finance	6880-0231-55023	IT-BIT
2/1/2026	KNOWLEDGEWAVE	260.00	Monthly subscription for 150 users for online IT training.	Information Services	Finance	6880-0231-55023	IT-FIN
2/1/2026	SQ *SQUARE PAID SERVICES	52.43	Library Square POS subscription payment.	Information Services	Finance	6880-0231-55023	IT-LIB
2/1/2026	WWW.FOREUP.COM	116.67	Work Order tracking system for Golf Course.	Information Services	Finance	6880-0231-55023	IT-560
2/2/2026	CABLESANDKITS	201.95	Cisco SFPs	Information Services	Finance	6880-0231-56004	IT-FIN
2/2/2026	CENTURYLINK LUMEN	1,544.59	Phone Bill January 2026	Information Services	Finance	6880-0231-54010	IT-FIN
2/2/2026	IN *GUARDIAN ALLIANCE TEC	60.00	Background Check Software	Information Services	Finance	6880-0231-55023	IT-POL
2/4/2026	INSIGHT PUBLIC SECTOR	4,702.32	BlueBeam yearly subscription for qty 14 of our 28 current yearly subscriptions.	Information Services	Finance	6880-0231-55023	IT-CDV
2/4/2026	MONOPRICE, INC.	106.99	Pack of 50 Cat6 network punchdown jacks.	Information Services	Finance	6880-0231-56006	IT-BIT
2/6/2026	AMAZON MKTPL*RUBKT3MW3	370.85	CradlePoint Antennas and Cell phone cases and screen protectors.	Information Services	Finance	6880-0231-56006	IT-BIT
2/7/2026	AMAZON MKTPL*M10FH2E13	13.83	CradlePoint Antennas and cell phone cases and screen protectors.	Information Services	Finance	6880-0231-56006	IT-BIT
2/8/2026	AMAZON MKTPL*AF4HM2EQ3	13.84	CradlePoint Antennas, cell phone cases, and screen protectors.	Information Services	Finance	6880-0231-56006	IT-BIT
2/8/2026	CLAUDE.AI SUBSCRIPTION	100.00	Single user per month subscription for Claude Max.	Information Services	Finance	6880-0231-55023	IT-FIN
2/8/2026	VZWRLSS*APOCC VISB	6,201.54	cell phone bill January 2026	Information Services	Finance	6880-0231-54010	IT-FIN
2/9/2026	MICROSOFT-G140302806	23.16	Microsoft Azure Cloud Data usage charges. Azure Update Manager - Basic \$4.35 Azure Monitor - Alerts \$1.49 Microsoft Defender for Resource Manager - Per node Std - US East \$5.13 Event Hubs - Basic (1M Ingress Events) \$0.57 Event Hubs - Basic (1 Throughput Unit Hour) \$11.16	Information Services	Finance	6880-0231-55023	IT-FIN
2/9/2026	SPRINGSHARE LLC	277.65	Patron Point Verify Subscription Oct-Dec 2025	Information Services	Finance	6880-0231-55023	IT-LIB
2/10/2026	WAITLIST ME, INC.	34.99	Software for the Imagination Studio	Information Services	Finance	6880-0231-56019	IT-555
2/12/2026	ATT* BILL PAYMENT	4,313.21	FirstNet cell data cards and phones January 2026	Information Services	Finance	6880-0231-54010	IT-FIN
2/12/2026	ATT* BILL PAYMENT	41.77	Squad 212 data usage	Information Services	Finance	6880-0231-54010	IT-FIN
2/13/2026	BARCODES GROUP, INC.	4,571.40	Qty 10 of printers for the squad car laptop update project.	Information Services	Finance	6880-0231-56004	IT-POL
2/13/2026	INSIGHT PUBLIC SECTOR	1,550.44	Two core packs of Windows Server 2025. One for VPN logging server and one for the LAMA server update project.	Information Services	Finance	6880-0231-56019	IT-BIT
2/15/2026	ADOBE INC	29.99	Stock Photo Subscription	Information Services	Finance	6880-0231-56019	IT-555

**Bettendorf City Council P-card Disbursements - Feb26 Statement - 03.03.26**

<b>Transaction Date</b>	<b>Vendor Name</b>	<b>Amount</b>	<b>Memo</b>	<b>Fund</b>	<b>Department</b>	<b>Account</b>	<b>Project</b>
2/15/2026	HOSTEDSCAN	348.00	Hosted Scan Basic - vulnerability scanner subscription. February 16, 2026-February 16, 2027	Information Services	Finance	6880-0231-55023	IT-BIT
		<b>70,376.30</b>		<b>Information Services Total</b>			
		<b>220,496.43</b>		<b>Grand Total</b>			